



iolite 12i

User Guide

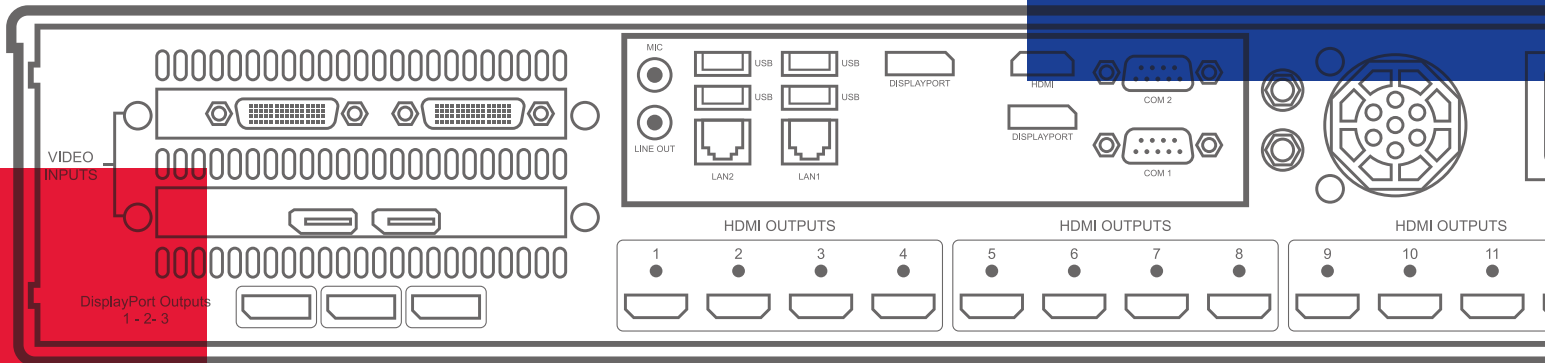

Table of Contents

Disclaimer/Copyright Statement.....	5
Quick Start Guide.....	6
Step 1 - Keyboard and Mouse.....	6
Step 2 - Connect to a Network (Optional).....	7
Step 3 - Connect Video Input Source (Optional).....	7
Step 4 - Powering up the System.....	8
Step 5 - Windows 10 Setup.....	8
Step 6 - Display Driver Configuration Tool (DDCT).....	9
Step 8 - WallControl 10 (Optional).....	13
Chapter 1 - Introduction.....	16
1.1 Introduction.....	16
1.2 Systems	16
1.3 How the User Guide is Organised.....	16
1.4 Fonts and Symbols.....	16
1.5 Terminology and Definitions.....	17
Chapter 2 - Unpacking.....	18
2.1 Unpacking and Initial Inspection.....	18
Chapter 3 - General.....	19
3.1 Overview.....	19
3.2 Associated Input Cards.....	19
3.3 Product Datasheets.....	19
Chapter 4 - Hardware.....	20
4.1 iolite 12i.....	20
Chapter 5 - Cabling.....	22
5.1 Connecting the Keyboard and Mouse.....	22
5.2 Connecting to a Network (Optional).....	22
5.3 Connecting Input Sources (Optional).....	23

5.4 Connect Monitors.....	23
5.5 Connecting Power Cables.....	24
Chapter 6 - Operation.....	25
6.1 Switching On.....	25
6.2 Initial System Boot on Delivery	26
6.3 Display Driver Configuration Tool (DDCT).....	27
6.4 Opening WallControl 10 (Optional).....	37
Chapter 7 - Software.....	39
7.1 WallControl 10 (Optional).....	39
7.2 WallControl 10 - Features and Tools.....	39
7.3 Opening WallControl 10.....	40
7.4 Wall Monitor (Optional).....	44
7.5 Vision Application (Optional).....	46
7.6 Software Utilities.....	48
Chapter 8 - Technical Support.....	49
8.1 Technical Support	49
Chapter 9 - Maintenance.....	50
9.1 Filter Maintenance.....	50
Chapter 10 - Environmental	51
10.1 Certification and Compliances.....	51
Chapter 11 - Specifications.....	52
11.2 Technical Specification - iolite 12i.....	53
Chapter 12 - Warranty.....	54
12.1 Warranty Statement.....	54
12.2 RMA Returns Policy.....	54

Chapter 13 - Advanced Users.....	56
13.1 Installing CODEC Packs to Play Video.....	56
13.2 Firmware Updates.....	56
13.3 Restoring Windows 10.....	56
Index.....	61

Disclaimer/Copyright Statement

© Datapath Ltd, England 2018

Datapath Limited claims copyright on this User Guide. No part of this User Guide may be reproduced, released, disclosed, stored in any electronic format, or used in whole or in part for any purpose other than stated herein without the express permission of Datapath Limited.

Whilst every effort is made to ensure that the information contained in this User Guide is correct, Datapath Limited make no representations or warranties with respect to the contents thereof, and do not accept liability for any errors or omissions.

Datapath reserves the right to change specification without prior notice and cannot assume responsibility for the use made of the information supplied. Datapath Limited acknowledges all registered trademarks used within this User Guide.

Quick Start Guide

A version of the Quick Start Guide is included below for your convenience.

Each Datapath iolite 12i is custom built to order therefore the components, number and type of inputs will differ from system to system.

Each iolite 12i is shipped with a printed diagram outlining the specific types of input(s) and where they are located on the rear panel of the system.

Any input cables supplied are clearly labeled and will indicate which of the video input connectors they relate to.

Step 1 - Keyboard and Mouse

Connect Keyboard and Mouse to convenient USB Ports.

USB Ports are located on both the front and rear panels of the system. If the intention is to mount the iolite12i in a rack, it may be more convenient to use the USB ports on the front for easy access.

- 4 x USB 3.0 ports on the rear panel
- 2 x USB 2.0 ports on the front panel

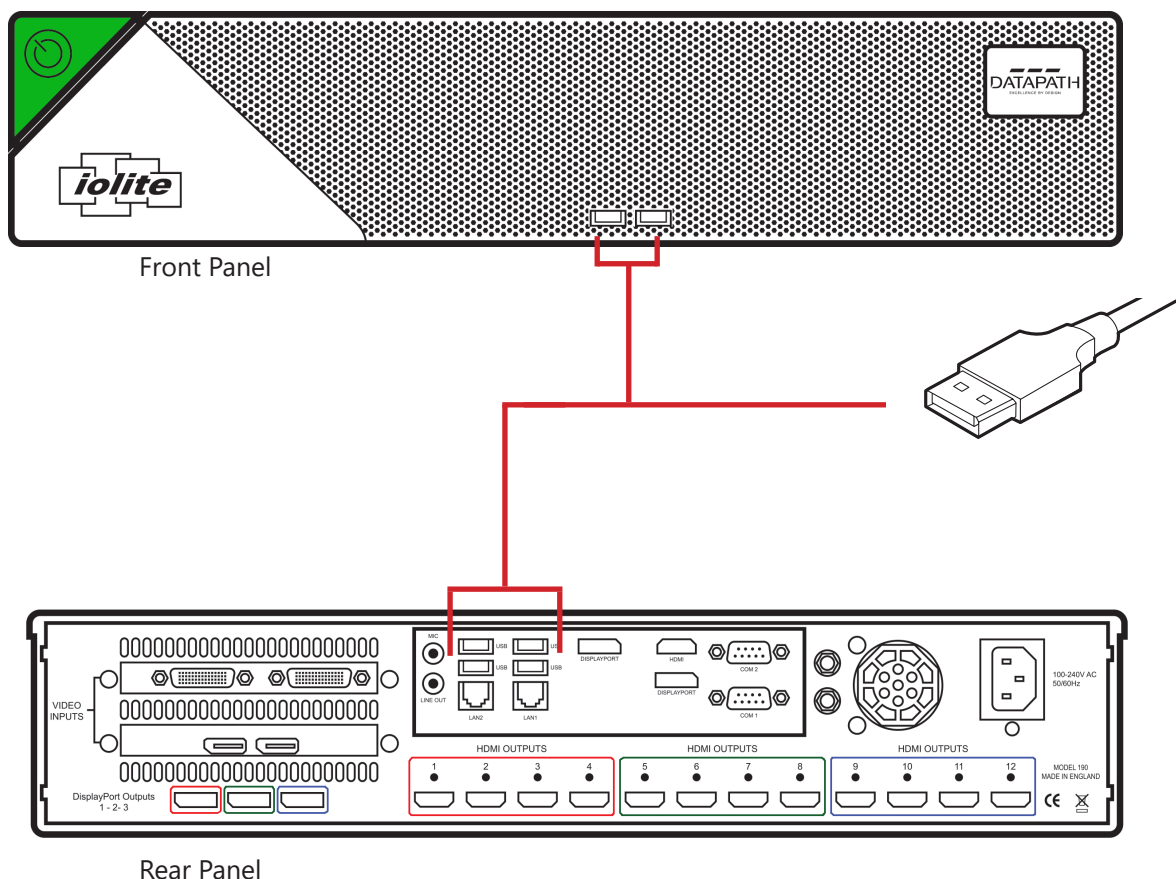

Step 2 - Connect to a Network (Optional)

If the iolite 12i is to be used over a network, connect the iolite 12i to a network point (cables not supplied) using one of the LAN connectors on the rear panel.

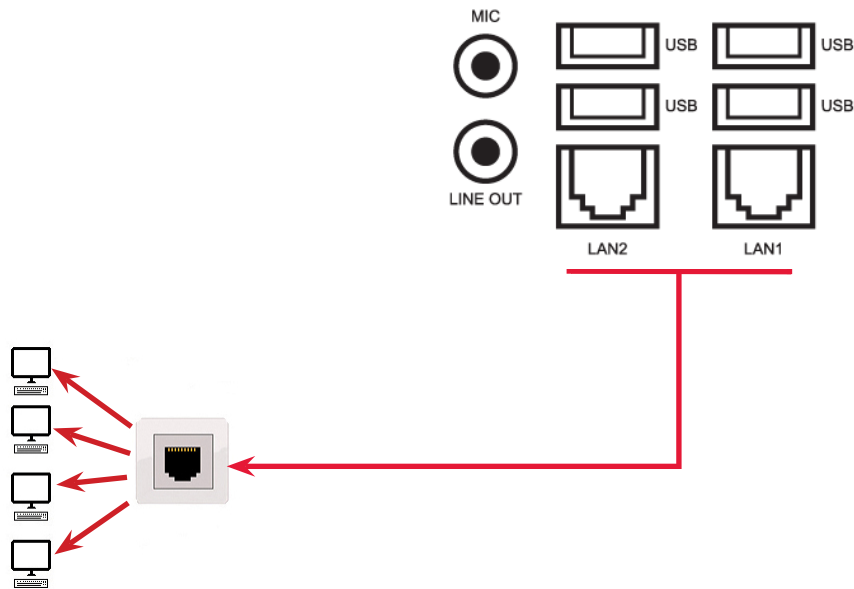

Step 3 - Connect Video Input Source (Optional)

As each iolite 12i is custom built, the number and type of video inputs will differ from system to system. If you have purchased an iolite 12i with video inputs, the input connectors are located on the rear panel as shown below.

The printed diagram shipped with the iolite 12i shows the types of input and connectors built into your specific system.

Connect the input sources to the relevant input connectors, cables may be supplied for some inputs. See content list for details.

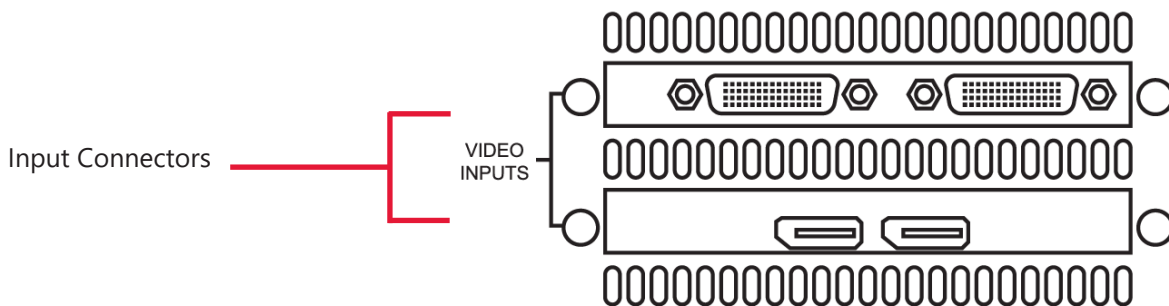

Step 4 - Powering up the System

Connect the power cable into the rear of the iolite 12i (1) then plug into a mains supply.

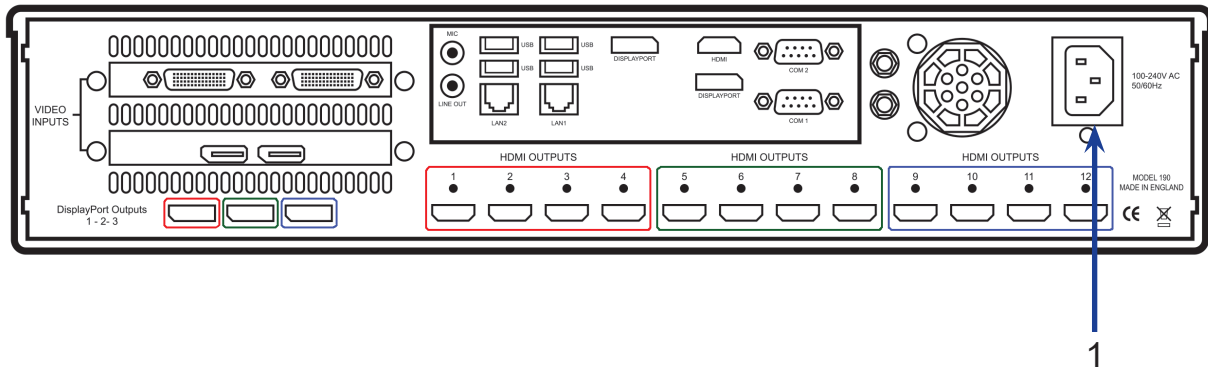

Press the on/off button (2) to power up the iolite 12i. There will be a short delay followed by the sound of the internal fan. The fan noise will subside when the system has fully booted.

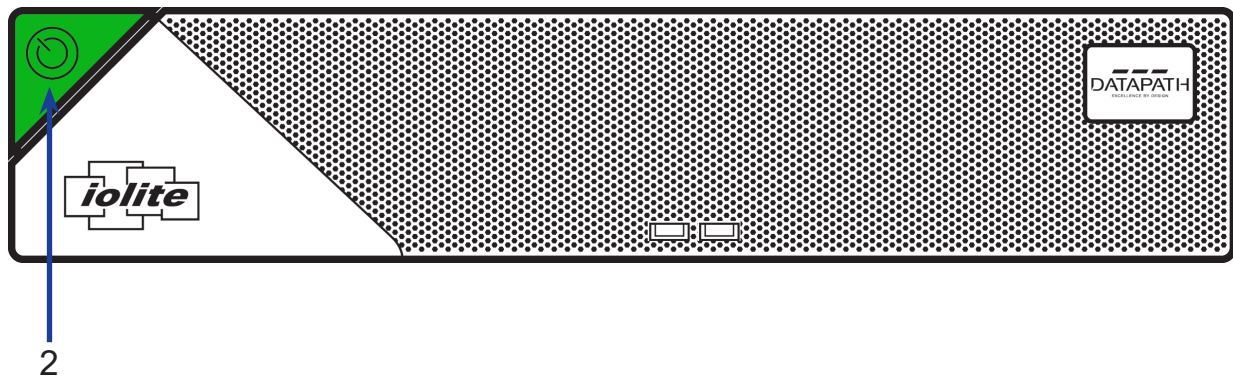

Step 5 - Windows 10 Setup

Once the system has been built and configured in our factory the operating system is resealed, therefore when switching the system on for the first time, the operating system setup commences. You will be prompted to enter information to set up the Windows 10 operating system.

There is no requirement for users to activate Windows 10, activation is done automatically. An internet connection is required to complete the automatic activation.

Step 6 - Display Driver Configuration Tool (DDCT)

Once the Windows 10 setup is complete, the system will reboot and the control screen will show a Windows desktop displaying the Display Driver Configuration Tool (DDCT). The DDCT will guide you, step by step, through the configuration of the graphics outputs, enabling you to quickly create one or more video walls.

On the final stage of the configuration, the DDCT will recommend the optimum way to connect your iolite 12i to your video wall displays.

A full description of the DDCT can be found in the User Guide located on the Documentation Media.

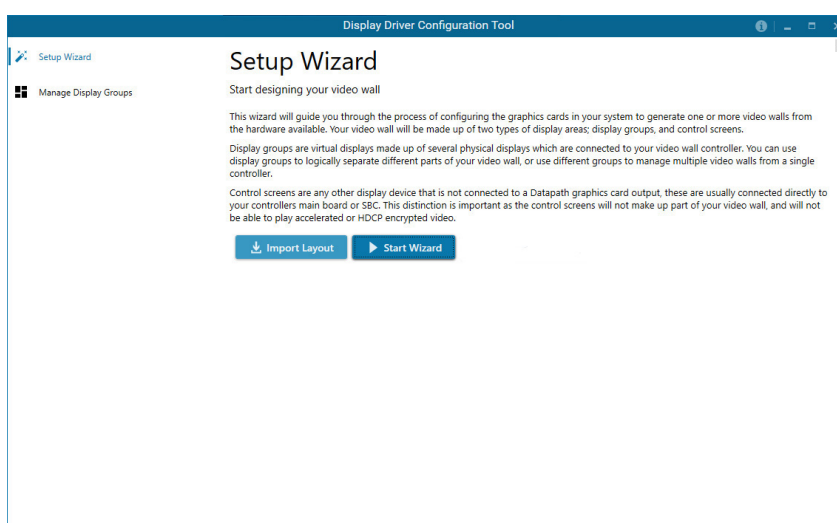

It is recommended that you carefully read the instructions on each page of the wizard. To commence your wall configuration, click on "Start Wizard" .

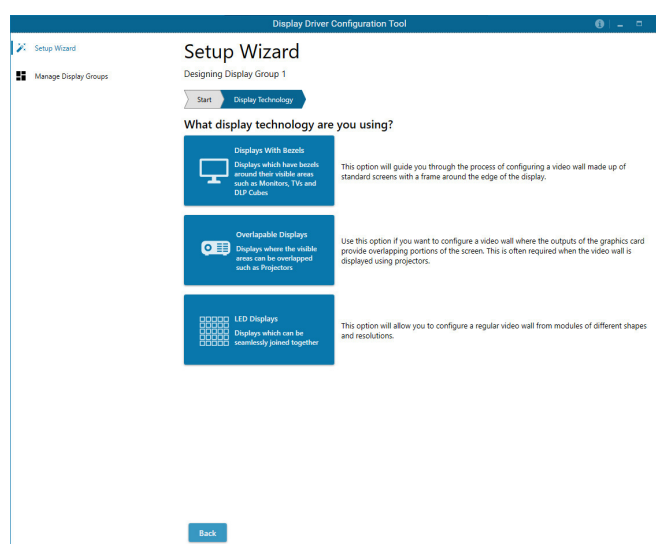

Select the type of displays being used on your wall:

- Displays With Bezels – Monitors, TVs and DLP Cubes.
- Overlapable Displays – Projectors.
- LED Displays.

Click on "Continue". The tool will then display a configuration page for the type of display you selected.

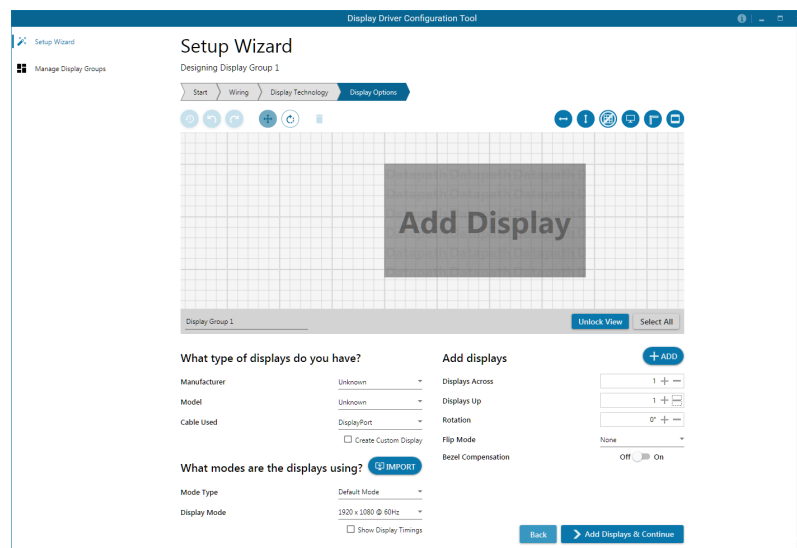

What Type of Displays do you Have?

Use the “Manufacturer” and “Model” dropdown lists to select the displays you are using for your wall. If the wall consists of different displays, select each one in turn to configure the type of display. The DDCT has an extensive database of displays, however if your display is not contained in the list, you can input the details manually by selecting “Create Custom Display”.

It is strongly recommended that measurements are taken from the display manufacturer’s specifications if available.

What type of displays do you have?

Manufacturer	Unknown
Model	Unknown
Cable Used	DisplayPort
	<input checked="" type="checkbox"/> Create Custom Display
Display Area Width	192 cm
Display Area Height	108 cm
Left Bezel	0 cm
Right Bezel	0 cm
Top Bezel	0 cm
Bottom Bezel	0 cm

Add Displays

Add Displays is available for displays with bezels or overlapable displays. Use the “Displays Across” and the “Displays Up” to create your Display Group. Once created, configure the displays using “What Type of Displays Do You Have?” When using overlapable displays “Display Overlap” becomes available, enabling you to select a percentage of overlap between displays.

Add displays + ADD

Displays Across 1 + -

Displays Up 1 +

Rotation 0° + -

Flip Mode None ▾

Bezel Compensation Off On

Back
➤ Add Displays & Continue

Once the layout has been created and the type(s) of displays configured click on “Add Displays & Continue” and the following dialogue is displayed:

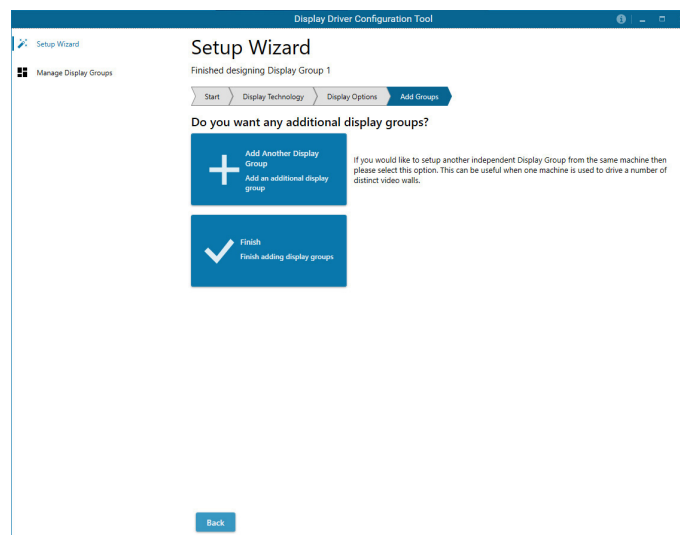

At this stage of the set up you can choose to create another independent display group from the same system, this would be considered if one machine will be used to drive a number of separate video walls. See User Guide for more details.

If another display group is not required, click on “Finish” and the following page is displayed:

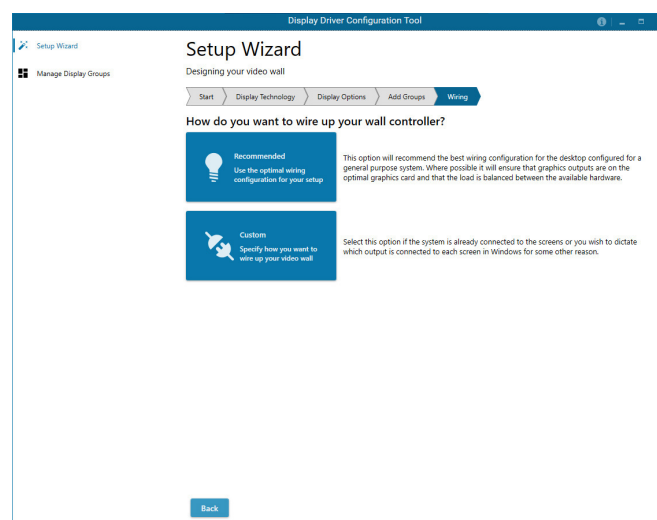

The DDCT can recommend the best wiring configuration for your system, ensuring the load is balanced between the graphics hardware. Click on "Recommended" for the optimal configuration for your system.

Should you wish to manually wire your system and decide for yourself which output is connected to which display, click on "Custom". Use the configuration matrix in Chapter 5 of the User Guide to determine the connection combinations available.

You will be next be presented with the Summary page:

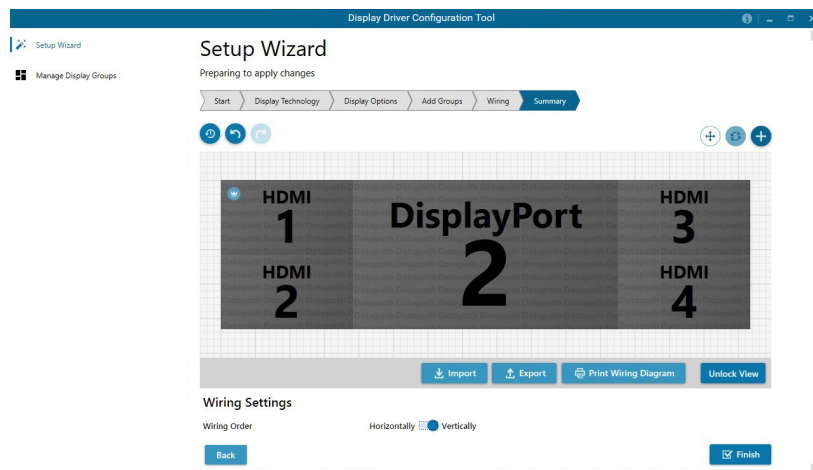

If you chose to have the DDCT configure your wiring this page will display the recommended connections, as shown above. Connect each display to the corresponding output connector on the rear of the iolite 12i. If your iolite 12i is connected to a printer, you can print a copy of the wiring diagram using "Print a Wiring Diagram".

Note: The Datapath Diagnostic Suite must be installed to print a wiring diagram. The suite can be downloaded from the Datapath website downloads page should it not already be installed on your system.

To manually select the outputs right click on the display group and select "Edit", you can then select each individual display and allocate your preferred output. Right click on a selected display to reveal the list of outputs available:

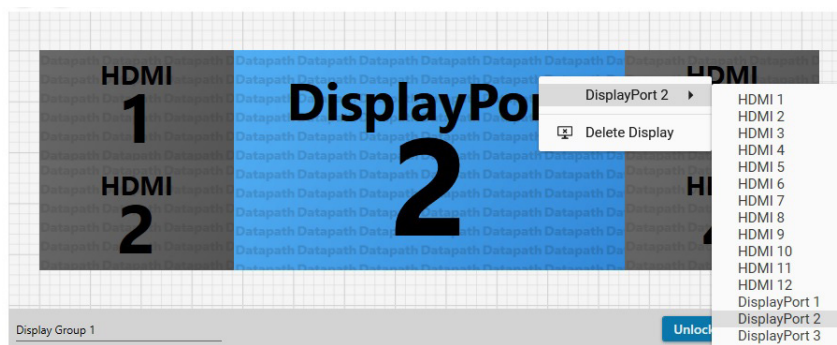

When all outputs have been allocated by either "Recommended" or "Custom" click on "Finish". You will then be prompted to save the changes to your video wall and restart your system. When restarted, the Windows Desktop will be displayed across the wall.

You can access the configuration tool at anytime should you wish to make changes. Right click on the desktop and select Display Driver Configuration Tool from the menu.

Step 8 - WallControl 10 (Optional)

Before opening the WallControl 10 Client interface you may need to start the WallControl 10 Server should it not start automatically. The Server icon is displayed in the System Tray.



If the Server fails to start automatically, start the Server by clicking on it in the "All Programs" menu. The WallControl 10 Client will only detect servers that are running.

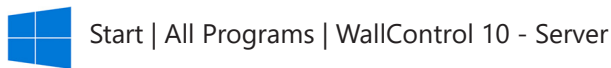

Open the WallControl 10 Client

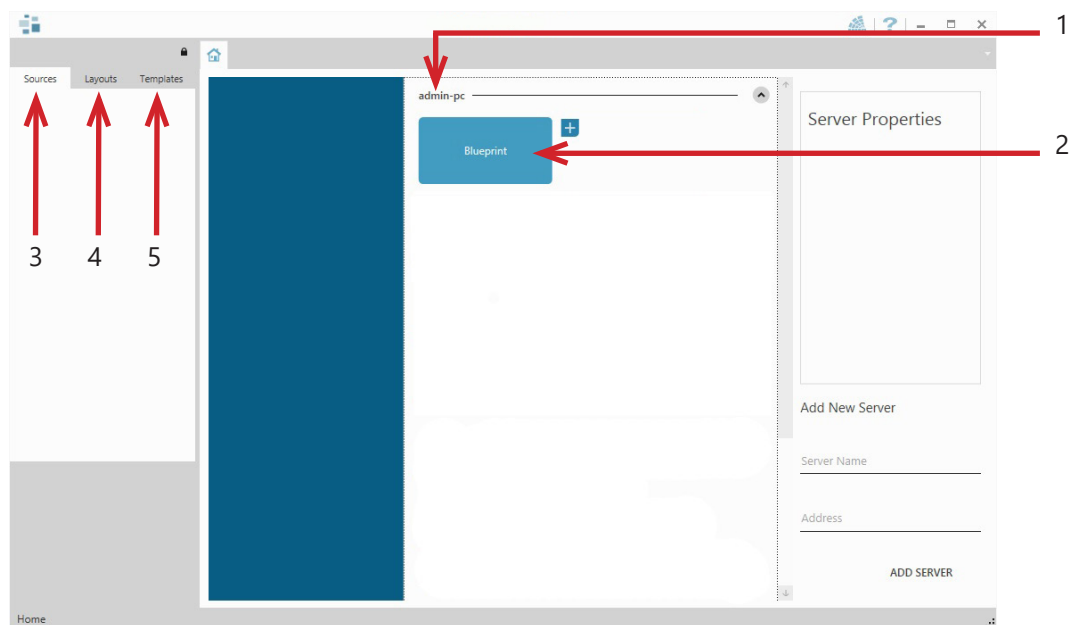
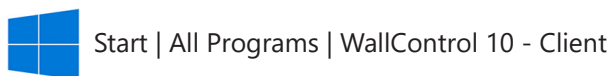

1	Indicates the server you are connected too.
2	A representation of the display wall associated with the server.
3	Sources Tab - Displaying all the sources connected to the server for use on the your display wall.
4	Layouts Tab - Used to save, recall and share display wall layout configurations.
5	Templates Tab - Use templates to assist in the design of specific display wall layouts.

Click on the display wall representation to open the display wall tab (2)

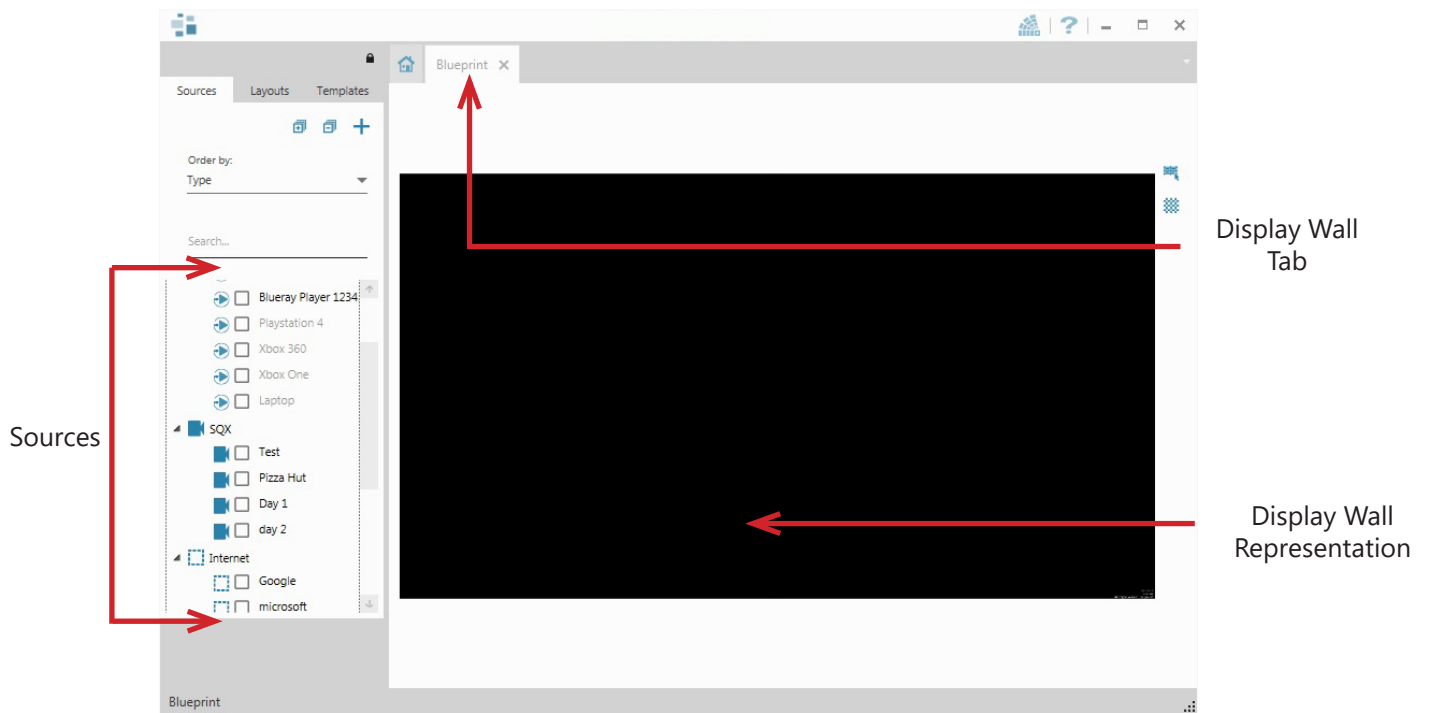

When opened, the display wall tab shows a live representation of the physical wall and the sources available to display on it. To place a source on the video wall, simply click on the required source in the Sources Tab and drag it onto a preferred position on the display wall representation.

The application help file is accessed using the question mark icon (?) located on the top right of the WallControl 10 Client. The help file contains information explaining how multiple sources can be selected, how to use and create templates, how to save, recall and share layout files and manage walls.

The WallControl 10 - Security Administration Client (Only Available with WallControl 10 Pro)

A WallControl 10-Pro serial dongle must be inserted into a vacant USB port. If the dongle is removed or swapped, the Security Client will not open and an error message is displayed, therefore it is important the dongle is not removed.

If you have purchased WallControl 10 Pro, the licence dongle can be located in the accessories box.

 Start | All Programs | WallControl 10 - Security Administration Client

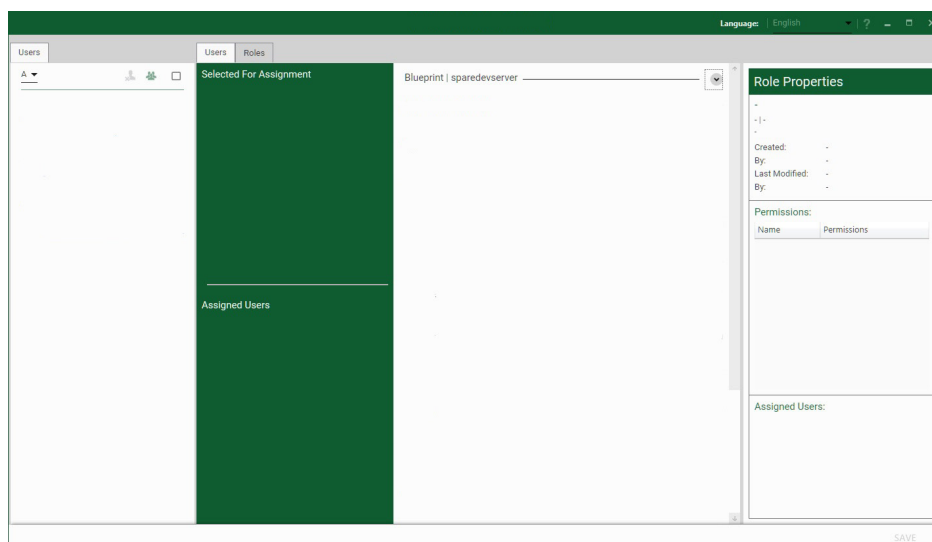

The WallControl 10 - Security Administration Client allows Administrators to assign specific users to roles on a wall by wall basis. For example, a user can be assigned a role allowing unrestricted access on one wall but assigned a role on another wall which only allows the opening of pre-determined layouts.

Prior to the Security Client being used for the first time, the SecurityOnOff.exe program must be running to enable security protection for the application. To manually run the SecurityOnOff.exe, ensure you are logged into Windows® with Administrator Rights.

Locate and double click on the SecurityOnOff.exe file:

Program Files|WallControl 10| Security Server|SecurityOnOff

The WallControl 10 Security Application help file contains information on how to:

- Import users from the Windows Active Directory into the database.
- Create and edit roles.
- Assign permissions to providers, layouts and sources giving specific roles access to them.
- Assign roles to walls.

Chapter 1 - Introduction

1.1 Introduction

Congratulations on your purchase of the Datapath iolite 12i. The wall controller has been manufactured and tested to the highest standards offering unparalleled quality and reliability. The aim of this user guide is to assist you through the installation of the system safely and effectively and act as a reference guide for future use. Do not switch on the system until all the relevant cables have been connected.

1.2 Systems

The system covered by this user guide is the iolite 12i display wall controller.

1.3 How the User Guide is Organised

The user guide is broken down into chapters and each chapter into sections. Chapters, sections and pages are numbered individually. Pages are numbered in Arabic numerals with the exception of the cover page (no numbering).

1.4 Fonts and Symbols

1.4.1 Fonts

The font used throughout the user guide is Corbel however the following font styles mean:

Bold = Used to describe menu titles, buttons in software or elements that you must type exactly as shown in the Command Line Interface

Ellipsis (...) - Parameter that can be repeated several times in a command line.

Between brackets ([]) - Optional items.

Between braces ({}) - Set of choices (separated by |) from which you must choose only one.





Italic = Information that must be supplied by the user

`Courier` = Indicates code or program output.

[Blue Underlined](#) = Indicates a hyper-link. Some hyper-links may be linked to external live websites.

1.4.2 Symbols

Symbols are used throughout this user guide to assist the user in quickly identifying important safety information and notes.

	Yellow triangle indicates that failure to observe the instructions could result in injury and/or damage to the system.
	Lifting precautions should be considered.
	White arrow in a blue box indicates a useful tip.
	White exclamation mark in a blue box indicates important information.

1.5 Terminology and Definitions

1.5.1 BIOS

Basic Input/Output System: Used during system boot up to initialise and test system hardware and load the operating system. Each BIOS is specifically designed to work with a particular motherboard. The motherboard documentation shipped with your system will give detailed information on the BIOS.

1.5.2 Control Screen

Some systems are shipped with the BIOS configured to boot the system off the onboard graphics device. This output can then be used as the Control Screen for a typical video wall. The content of the control screen is not displayed on the video wall desktop and can be used to host the Wall Control application window.

1.5.3 SDK

Software Development Kit: A set of software development tools which allows the creation of certain applications

1.5.4 WallControl 10

WallControl 10 provides users with the interface required to quickly and effectively manage content that include video captures, IP streams and local applications. Users are able to place any input source on any part of the Video Wall using a simple drag and drop operation. Precise positioning of each piece of content can be achieved through the mouse and keyboard, or via the revolutionary template tool.

1.5.6 Wall Monitor

A software application that enables the user to monitor the temperatures and voltages of system components.

1.5.8 SQX

SQX is Datapath's collective name for its video streaming and compression technologies.

Chapter 2 - Unpacking

2.1 Unpacking and Initial Inspection

To unpack the system follow the instructions provided on the outside of the packaging. All packaging materials should be retained for future transit.

2.1.1 Initial Inspection

All systems are carefully prepared for shipment and every effort is made to ensure you receive the product in pristine condition. On receipt, you should carefully inspect the outer packaging for any transit damage i.e. any signs that the system may have been dropped etc.

Check the chassis for damage that could have an adverse affect on the operation of the system or could cause injury to the operator. Should there be any physical damage to the power supply unit, for example damaged power sockets or exposed wiring do not connect to a power source, contact Datapath for further instructions.

Chapter 3 - General

3.1 Overview

Datapath's iolite 12i platform is a simple video wall solution that can be used not only as part of a Command and Control deployment but also in smaller more discrete environments such as Retail Display, Corporate Headquarters and Boardrooms as part of a presentation or collaboration system.

The iolite 12i range is fully compatible with Datapath's half length Vision capture cards. There are also four preconfigured systems available to order. The system has a very small footprint and has been designed to be very quiet for deployment in areas that would not support a standard sized wall controller chassis

Each system has been designed for use in demanding environments. The components have been subjected to rigorous testing to ensure the highest levels of performance and reliability.

In summary:

- High performance and reliability in demanding conditions
- Suited for 24/7 applications
- Can be operated via a network
- WallControl 10 software (optional) - Display video on the desktop in real time using an array of features

3.2 Associated Input Cards

The following table lists the range of Datapath products associated with the iolite 12i video wall solution:

Product	Description
ActiveSQX	Dedicated IP Streaming decoding card.
VisionSC-DP2	Dual channel, 4K UHD DisplayPort capture card.
VisionSC-SDI4	Four channel 3G-SDI video capture card.
VisionSC-HD4+	Quad HDMI video capture card.
VisionAV-HD	Four lane PCI Express capture card with 2 x HD DVI-I and 1 SD channels.
VisionSD8	Eight channel SD video capture card.

For the latest details on our full product range please visit our website: www.datapath.co.uk

3.3 Product Datasheets

Product datasheets are available to download from www.datapath.co.uk

Chapter 4 - Hardware

4.1 iolite 12i

4.1.1 Front

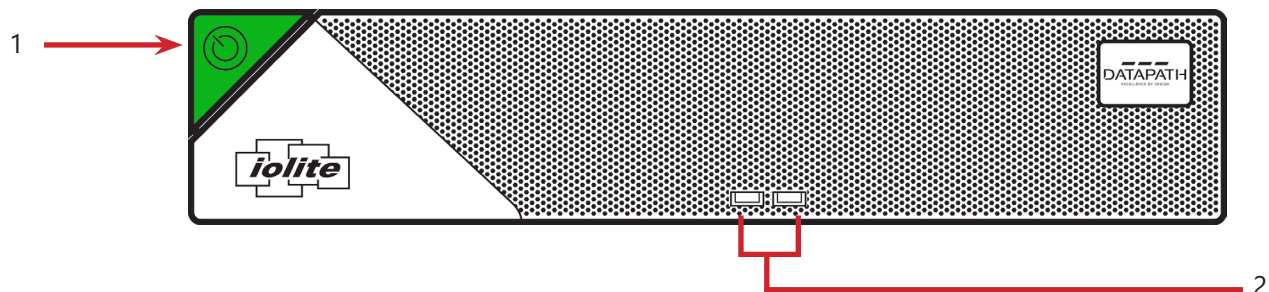

1 = Power, on-off	2 = USB Ports
-------------------	---------------

4.1.2 Rear

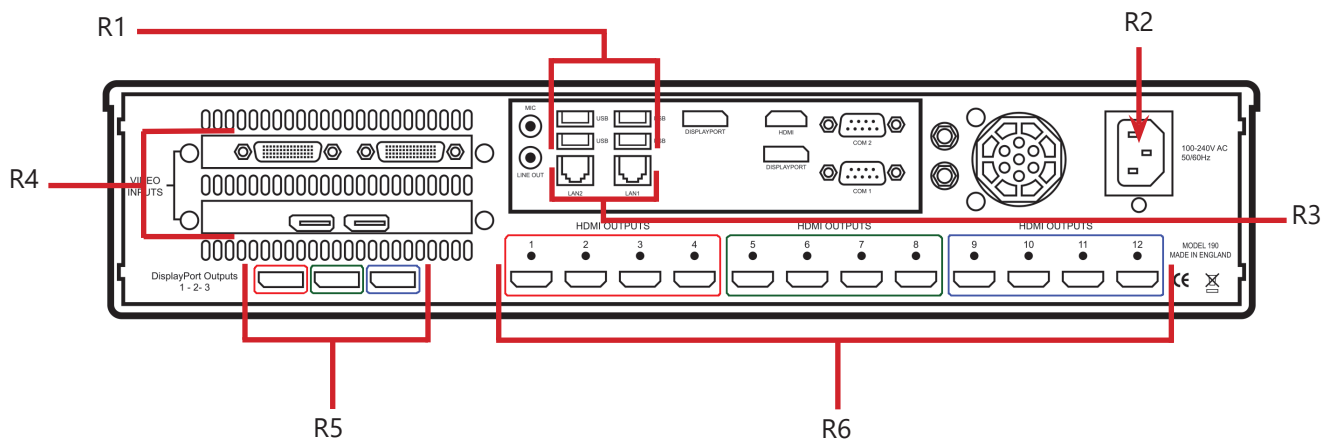

R1 = USB Ports	R3 = Ethernet Ports
R2 = Power Connector	R4 = Video Inputs
R5 = DisplayPort Outputs	R6 = HDMI Outputs

4.1.3 Rack Mounting the iolite 12i

The iolite 12i is supplied with attachments to enable you to mount the system in a rack. Remove the 4 mounting screws on each side of the iolite using a cross head screwdriver and attach the rack mounts as shown in the illustration below:

Remove the screws on the system and secure the rack mounts using the screws provided

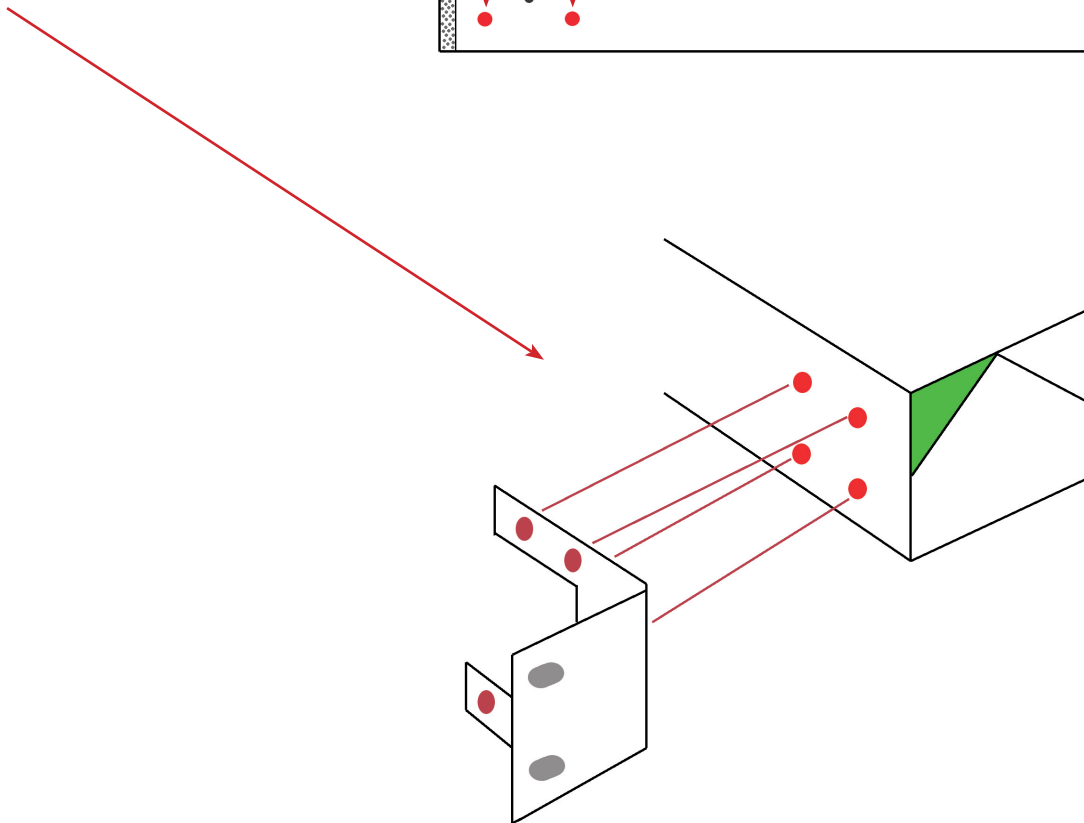

Chapter 5 - Cabling

This Chapter will cover:

- Connecting keyboard and mouse
- Connecting to a network
- Connecting input sources
- Connecting monitors
- Connecting power cables

5.1 Connecting the Keyboard and Mouse

The keyboard and mouse supplied with your system both have a USB interface. Identify convenient vacant USB ports on the chassis and plug them in.



The location of the USB ports are identified in the previous chapter.

5.2 Connecting to a Network (Optional)

The optional WallControl 10 software enables the user to operate and manage the video wall display remotely, via a network. The iolite 12i can have up to two Ethernet ports, plug your network cable (not supplied) into any network port and connect the iolite 12i to the LAN, as shown below:

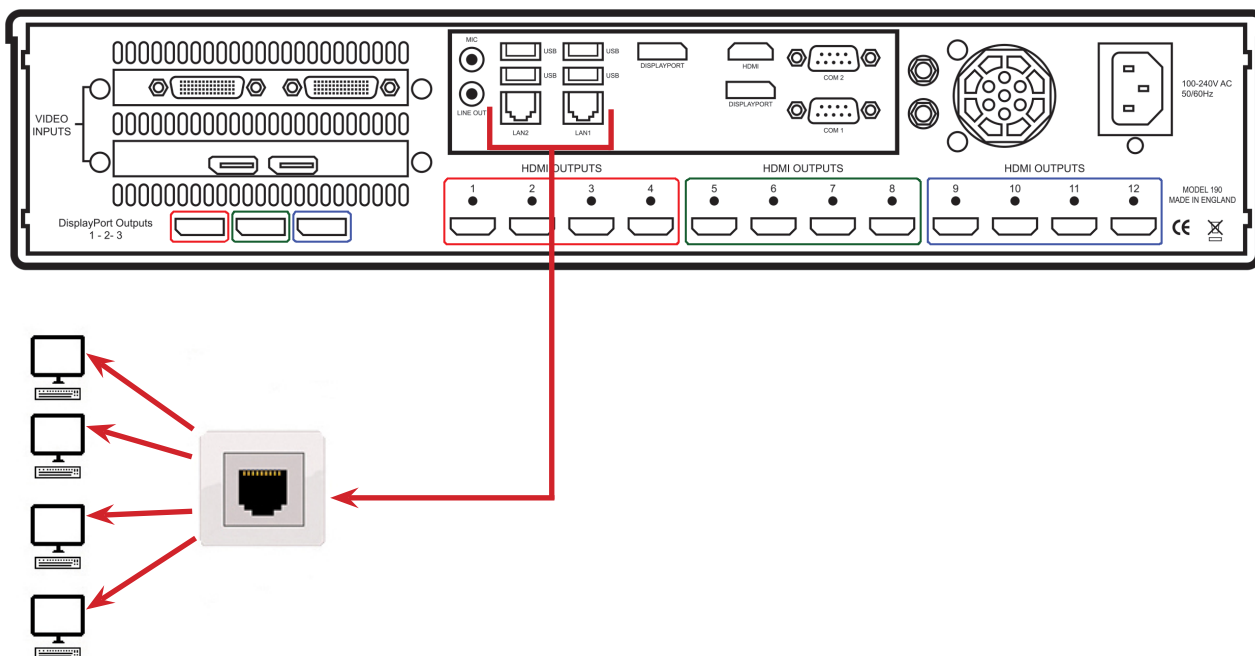

5.2.1 Network Security

It should be noted that network ports have a potential vulnerability. If your system is working in a secure environment you probably don't need to worry about unauthorised access to the LAN port. If your system is on a network that is generally accessible, you will probably want to restrict access to the ports.

5.3 Connecting Input Sources (Optional)

Each iolite 12i will differ depending on the models of input cards installed. The build log document enclosed with your system will enable you to establish which input cards you have installed in your iolite 12i.

Contained within the product documentation folder are PCIe card product leaflets which give details on any accessories which may accompany them. For detailed information on specific cards please consult the relevant User Manual. Each capture card manual can be located on the Datapath Recovery Media supplied with your system.

5.3.1 Cable Handling



Great care must be taken when connecting cables to the iolite 12i. Ensure the cable connectors are the correct type for the input and output connectors. Push the cable connector on squarely, there is no requirement to force the connector in place. Poor cable handling could result in damaged pins in the cable connector, this in turn could cause serious and irreversible damage to the printed circuit boards inside the system. Any damage caused this way is not covered under warranty.

5.4 Connect Monitors

Each system can support any number of screens from 1 to 12 depending on user requirements. The Display Driver Configuration Tool will guide users through the complete configuration of your display walls (Chapter 6). The tool will be presented to the user once the Operating System has been configured on initial boot up.

It is strongly recommended that the HDMI Cable Locks (provided) are used to secure cables to the HDMI output connectors on the rear of your iolite 12i.

The iolite 12i has 12 integrated HDMI outputs and three 4k DisplayPort outputs. The HDMI ports are configured in three groups of four outputs, each group is colour coded. Red outputs 1-4, Green 5-8 and Blue 9-12. All HDMI ports in each group must be configured to operate at the same resolution, with a maximum resolution of 1920x1080 at 60 frames per second.

Each DisplayPort connection can be used instead of four HDMI, for example, if DisplayPort 1 is used then HDMI connectors 1-4 are redundant.

The following table illustrates the combinations available:

DisplayPort Outputs

1	2	3
X	X	X
✓	X	X
X	✓	X
✓	✓	X
✓	✓	✓
X	✓	✓
✓	X	✓
X	X	✓

HDMI Outputs

1	2	3	4	5	6	7	8	9	10	11	12
✓	✓	✓	✓	✓	✓	✓	✓	✓	✓	✓	✓
X	X	X	X	✓	✓	✓	✓	✓	✓	✓	✓
✓	✓	✓	✓	X	X	X	X	✓	✓	✓	✓
X	X	X	X	X	X	X	X	✓	✓	✓	✓
X	X	X	X	X	X	X	X	X	X	X	X
✓	✓	✓	✓	X	X	X	X	X	X	X	X
X	X	X	X	✓	✓	✓	✓	X	X	X	X
✓	✓	✓	✓	✓	✓	✓	✓	X	X	X	X

DisplayPort Outputs 1 - 2- 3

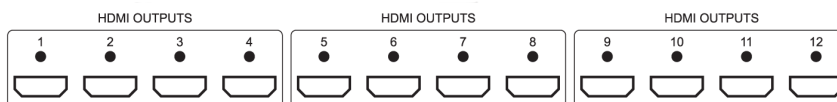

O = Used
X = Not Used

5.5 Connecting Power Cables

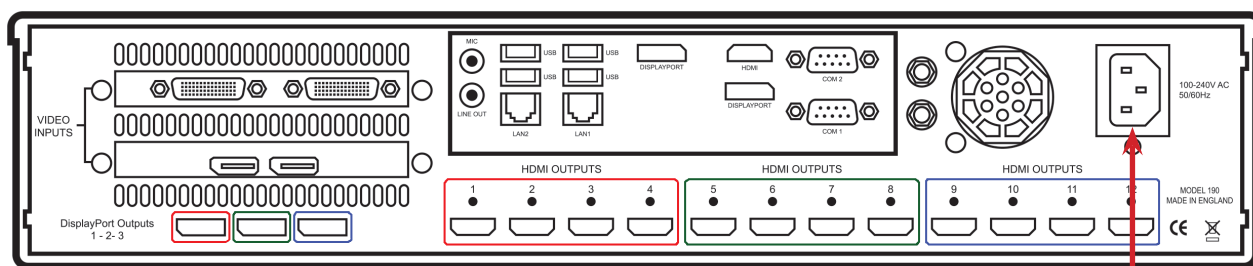

Insert Power Cable

Ensure your cable is fully inserted into the power supply socket, failure to do so could result in the cable becoming dislodged and the system inadvertently shutting down.



Only use the power cables supplied with your system, for advice on replacements please contact Datapath.

Chapter 6 - Operation

This chapter will cover:

- Switching on
- Initial system boot on delivery
- Setting up the operating system
- Configure a display wall using the Display Driver Configuration Tool
- Opening WallControl 10
- Displaying source captures

6.1 Switching On

When switching the system on for the first time you will need to complete the initial system boot steps as described in Initial System Boot on Delivery below. To carry out these steps, a display will need to be connected to either the DisplayPort 1 or the HDMI 1 connector on the iolite 12i.

6.1.1 Switching on the System

Ensure the mains power cable is correctly connected then turn on the iolite 12i.

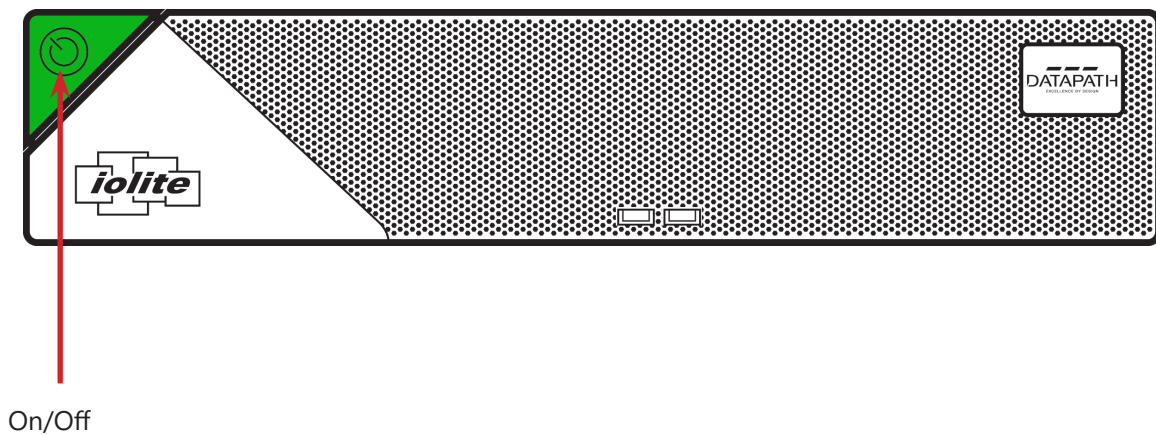

Turn on the iolite 12i using the power switch located on the front panel. There will be a short delay followed by the sound of the internal fan. The fan noise will subside when the system has fully booted.

The BIOS and boot messages will be displayed on the connected screen as the system boots. Once the system boot up is complete, the screen will open up a Windows desktop.

6.2 Initial System Boot on Delivery

Once the system has been configured in the factory the operating system is resealed, meaning that when switching on the system for the first time the operating system setup commences.

You will be prompted to enter information to set up the iolite 12i.

6.2.1 Select Language Pack

You will now be prompted to set up your Windows 10 operating system starting with selecting the language option you require. Language selection is the responsibility of the customer and is not part of the system pre configuration prior to shipment. Windows 10 language settings can be changed using **Control Panel/Language**. Language packs are available to download as optional updates. The following languages are pre-installed:

- German
- English (UK)
- English (USA)
- Spanish
- French
- Italian
- Japanese
- Netherlands
- Polish
- Portuguese (Brazilian)
- Russian
- Simplified Chinese

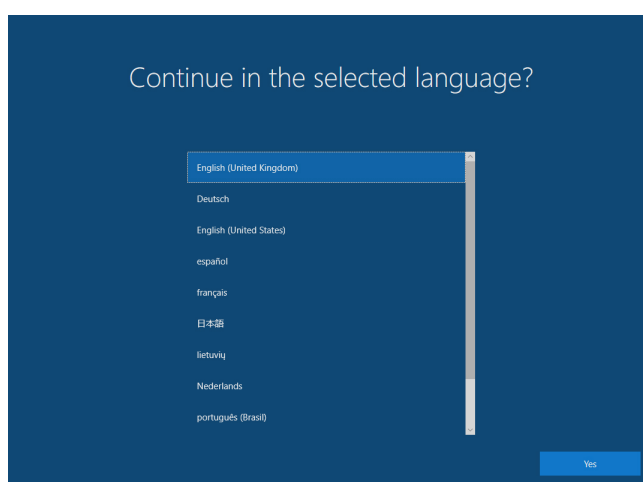

6.2.2 Select Country and Region - Windows 10

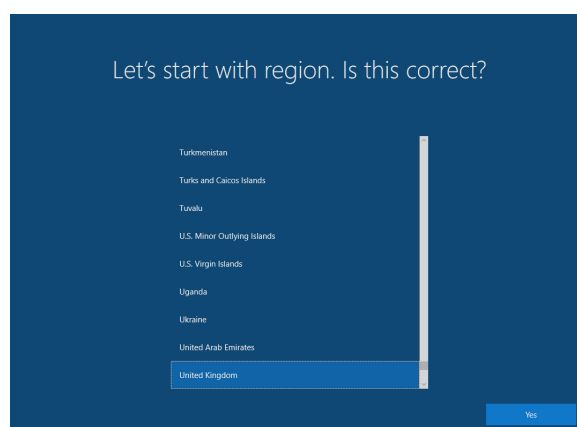

Use the scroll bar to select the region, the time zone and currency and the keyboard layout. These localised settings can be changed if required using the dialogue in **Control Panel/Region and Language**. You will then be required to accept the Windows® 10 Licence Agreement before moving on to create an account.

6.2.3 Names and Password

Next you will be prompted to create an account for your computer by entering a user name, a computer name and a password.

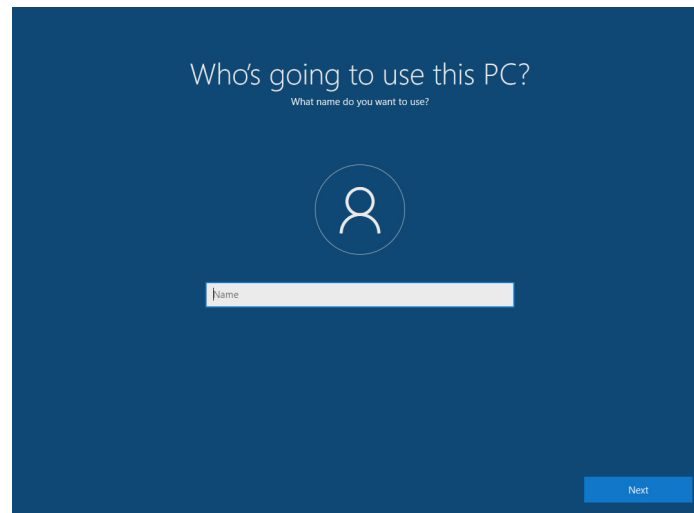

It is recommended that only Internet-standard characters are used in the computer name. The standard characters are the numbers 0 through to 9, upper and lower-case letters from A through to Z and the hyphen character. Computer names cannot consist entirely of numbers, contain spaces or use special characters such as: < > ; : " ? * + = \ | ? , .

You will then be prompted to create a password and three security questions, the security questions are compulsory once a password has been created.

Your Windows® 10 system does not require a product key to activate the operating system.

6.2.4 System Backup

It is strongly recommended that some form of system recovery media is created once your system is up and running. This will enable you to restore your Windows 10 Operating System should serious problems occur.

See Chapter 13 for details on how to create your own Windows 10 restore media.

6.3 Display Driver Configuration Tool (DDCT)

The DDCT is a configuration tool designed to guide you through the design and creation of your video wall using an iolite 12i system.

Once the Windows Operating System has been configured and rebooted, the DDCT is displayed on your screen.

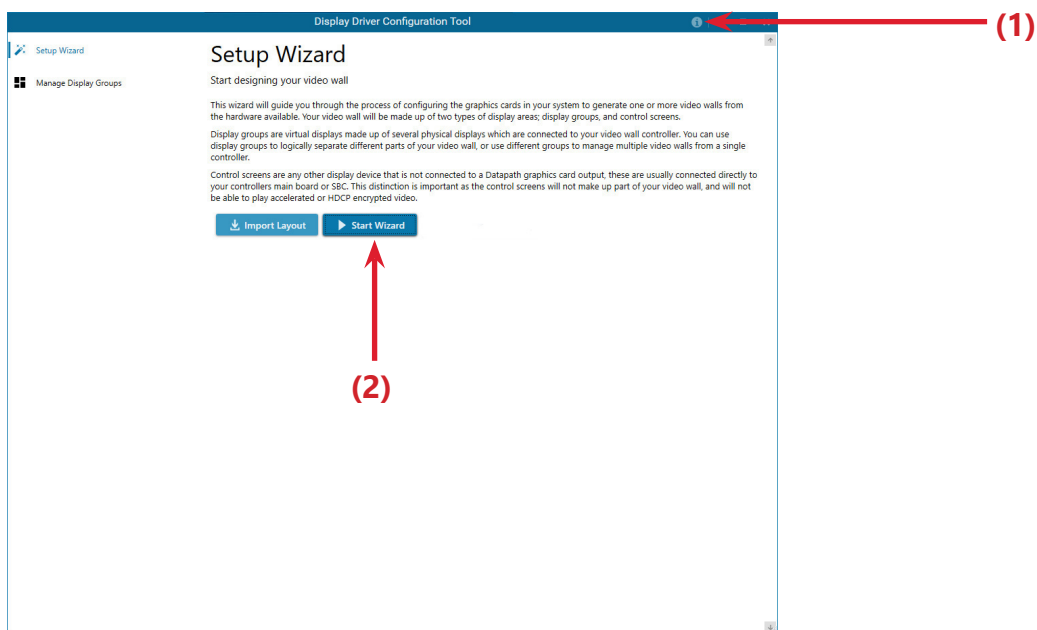

It is recommended that you read the information on each page carefully.

Click on the "Information Icon" (1) to open a sliding window which gives version details and copyright information. The latest version of the DDCT is available to download from the Datapath website.

To commence your wall configuration, click on "Start Wizard" (2). "Import Layout" is covered later.

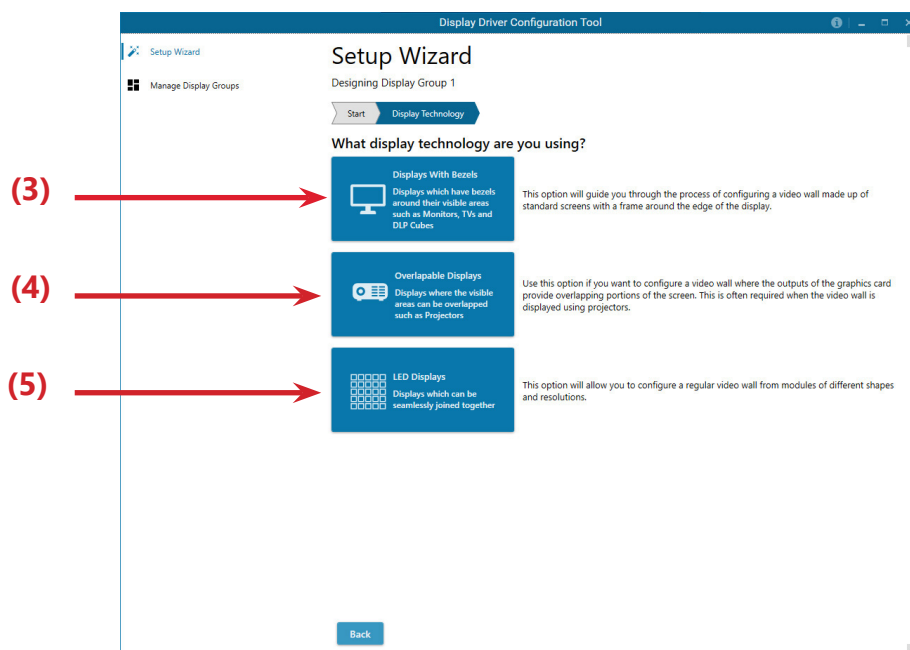

6.3.1 Display Technology

Select the type of displays being used on your wall.

- Displays With Bezels – Monitors, TV's and DLP Cubes. (3)
- Overlapable Displays – Projectors (4)
- LED Displays. (5)

Click on "Continue".

The tool will then display a configuration page for the type of display you selected:

6.3.2 Displays with Bezels

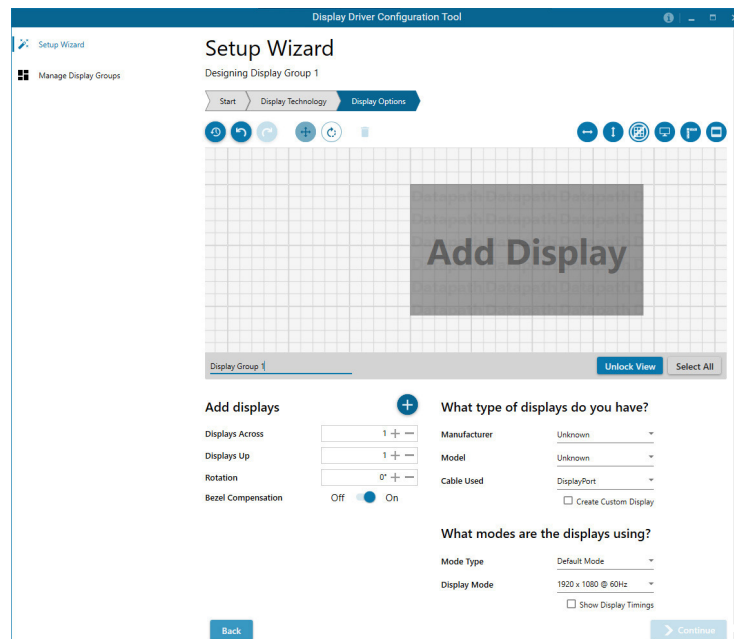

6.3.3 Overlapable Displays

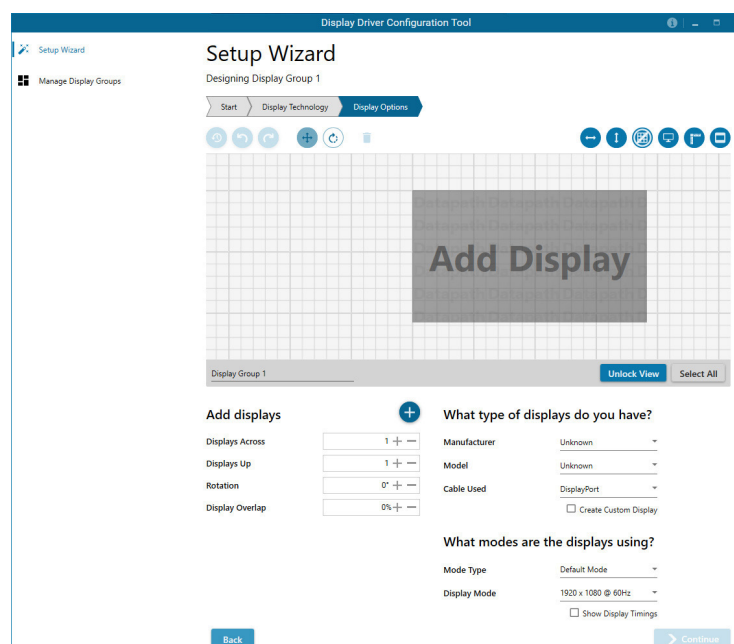



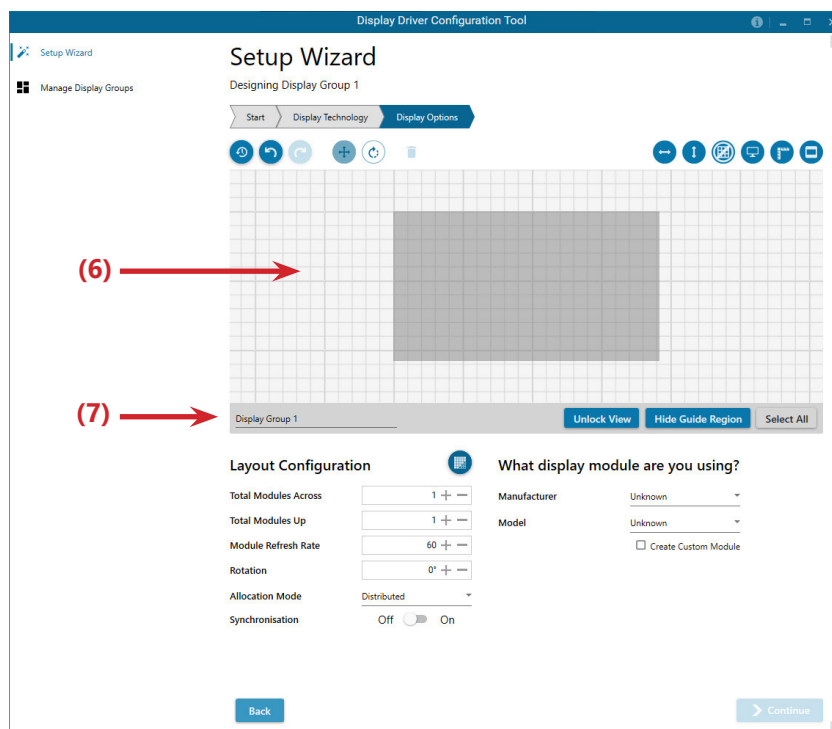

6.3.4 LED Displays



6.3.5 Application Tools

The application tools enable the user to manipulate the design of the wall. The table below describes the tool functionalities

	Undo All – Undo all commands made on this page.
	Undo – Undo the last command.
	Redo – Redo the last command.
	Move displays – When selected, move the displays by clicking on and dragging the displays around the representation.
	Rotate displays – When selected click on a display and drag the cursor up or down, left or right to rotate the display. The display can be rotated 90, 180 or 270 degrees.
	Delete displays/Display Groups – Select the displays you wish to remove from the layout then click on the delete button to delete all those selected.
	Enable X Axis – Enables the display to be moved from left to right, and right to left.
	Enable Y Axis – Enables the display to be moved up and down
	Snap to Grid – When selected, if a display is dragged and released it will snap and position itself to the nearest grid line.
	Snap to displays – When selected, if a display is dragged close to another display and released, it will snap and position itself to the display.
	Snap to Guides – When selected, if the display is dragged and released near to the axis of another display it will position itself on the same axis.
	Show Display Bezels – Select to show or hide the bezels on all the displays in the representation.
	Configure Outputs - Available in the Manage Display Group dialogue. Select an output and configure its properties.

	Add Button- Used to add displays to your group or to create a new group.
	Layout Configuration - Used to add LED modules to your group or to create a new group..
	Edit - Used to edit a selected Display Group
	Primary Display - Indicates which display within the display group is the primary display/boot screen. If more than one group is available, the Primary Display can be assigned to either group.

Representation

The representation grid (6) displays the physical arrangement of the wall as it is being created. Displays can be arranged as required by clicking and dragging them to their required positions using the application tools.

Wall Naming

Click on the edit box (7) to allocate a name to your wall (optional but recommended). This will be used if you choose to export your layout in the future.

Unlock View

When unlocked, the wall representation can be dragged to a preferred position using the mouse. Use the mouse wheel to zoom in and out of the representation.

Select All

Choosing "Select All" enables the user to select all the displays on the representation to apply common attributes to all displays.

6.3.6 Add Displays

Add displays is available for displays with bezels or overlapable displays. It enables you to configure the layout of your wall or display group. Use the "Displays Across" and the "Displays Up" to create a plan of your layout. Once your layout has been created you can then configure the displays using "What Type of Displays Do You Have?" When using overlapable displays "Display Overlap" becomes available enabling you to select a percentage of overlap between displays.

6.3.7 What Type of Displays Do You Have?

Displays with Bezels and Overlapable Displays

The first step to creating your wall is to select the type of displays you have. Use the "Manufacturer" and "Model" dropdown lists to select each display you are using on your wall. The DDCT has an extensive database of displays, however if your display is not contained in the list, you can input its details manually by selecting "Create Custom Display".

What type of displays do you have?

Manufacturer	Unknown
Model	Unknown
Cable Used	DisplayPort
	<input checked="" type="checkbox"/> Create Custom Display
Display Area Width	192 cm
Display Area Height	108 cm
Left Bezel	0 cm
Right Bezel	0 cm
Top Bezel	0 cm
Bottom Bezel	0 cm

It is strongly recommended that measurements are taken from the display manufacturers specifications if available.

Cables Used

Select the cable types for each monitor. Use the output configuration matrix in Chapter 5 to determine the types of output cable combinations available. An error message will be displayed if the cable limits are exceeded.

6.3.8 What Modes are the Displays Using?

Use the drop down lists to select the “Mode Type” and “Display Mode” for your selected display. Select “Show Display Timings” if you wish to view the display timings.

6.3.9 Layout Configuration

Layout Configuration is available if LED display technology has been selected.

The layout configuration setting enables you configure the layout of your wall or display group. Use the “Total Modules Across” and the “Total Modules Up” to create a plan of your layout. Once your layout has been created then you can configure the modules using “What display module are you using”.

Allocation Mode

The “Allocation Mode” enables you to select how the distribution of the modules is configured.

Distributed

Creates an even distribution of the modules from all the system outputs. (Recommended)

Unbalanced

Creates an uneven distribution of modules by allocating as many pixels to the first modules as possible. This creates an unbalanced load on the system outputs.

Synchronisation

Synchronises all the outputs in the system.

It is recommended that the synchronisation is set to “On”. Turning “Off” the synchronisation can cause tearing when a video source is displayed however it does allow display timings to be edited manually.

6.3.10 What display module are you using?

The first step to creating your wall is to select the type of LED modules you have. Use the “Manufacturer” and “Model” dropdown lists to select the LED module you are using on your wall. The DDCT has an extensive database of modules, however if yours is not contained in the list, you can input its details manually by selecting “Create Custom Module”.

What display module are you using?

Manufacturer	Unknown
Model	Unknown
	<input checked="" type="checkbox"/> Create custom module
Width	1920 + -
Height	1080 + -
Max Output Width	1920 + -
Max Output Height	1080 + -
Physical Module Width	192 cm + -
Physical Module Height	108 cm + -
Pixel Pitch	1 mm + -

It is strongly recommended that measurements are taken from the display manufacturers specifications if available.

Once a layout has been designed and the type of displays have been selected you can add the displays to the representation by clicking on the "Add Displays" icon or "Layout Configurations" if LED modules are being used.

When displayed on the Representation Grid", each display can be configured separately by clicking on it. Use the tools to position your displays creating the desired layout. To deselect the display, click on it again.

When the display wall or display group has been finalised click on "Continue" and the following page is displayed:

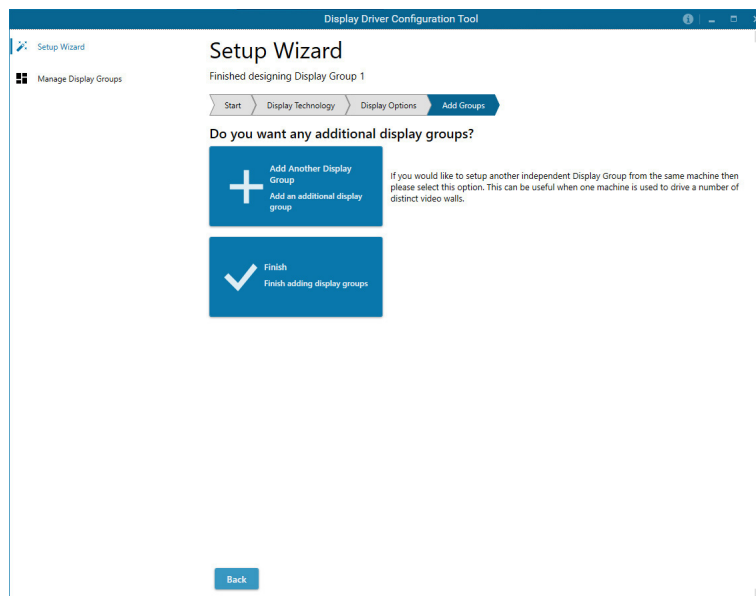

6.3.11 Add Groups

At this stage of the set up you can choose to create another independent display group from the same system, this would be considered if one machine will be used to drive a number of separate video walls.

Click on the "Add Another Display Group" should you wish to add another group of displays, this will return you to the "Display Technology" page. It should be noted that when creating new display groups there is no restriction to the type of display technology you can use for each group you create.

If another display group is not required, click on "Finish" and the following page is displayed.

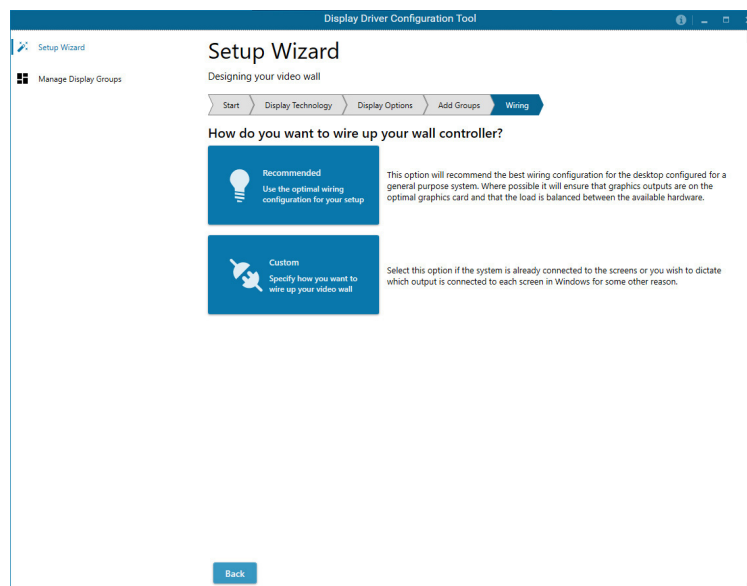

6.3.12 Wiring

How do you want to wire up your wall controller?

The DDCT can recommend the best wiring configuration for your system, ensuring the load is balanced between the graphics hardware. Click on "Recommended" for the optimal configuration for your system.

Should you wish to manually wire your system and decide for yourself which output is connected to which display, click on "Custom". Use the configuration matrix in Chapter 5 to determine the connection combinations available.

You will be next be presented with the Summary Page:

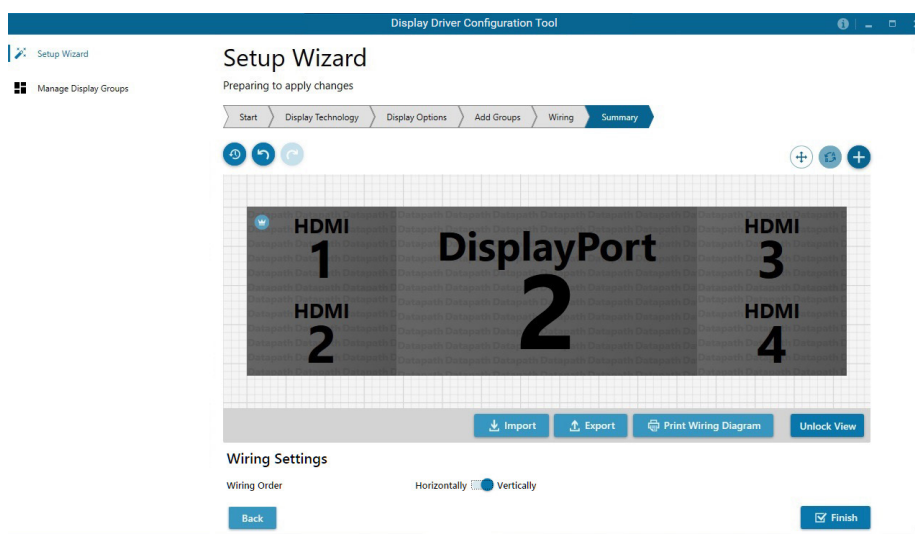

If you chose to have the DDCT configure your wiring then the page will display the recommended connections, as shown above. You can print a copy of the wiring diagram using "Print a Wiring Diagram".

Note: The Datapath Diagnostic Suite must be installed to print a wiring diagram. The suite can be downloaded from the Datapath website downloads page.

To manually select the outputs right click on the display group and select "Edit", you can then select each individual display and allocate your preferred output. Right click on a selected display to reveal the list of outputs available:

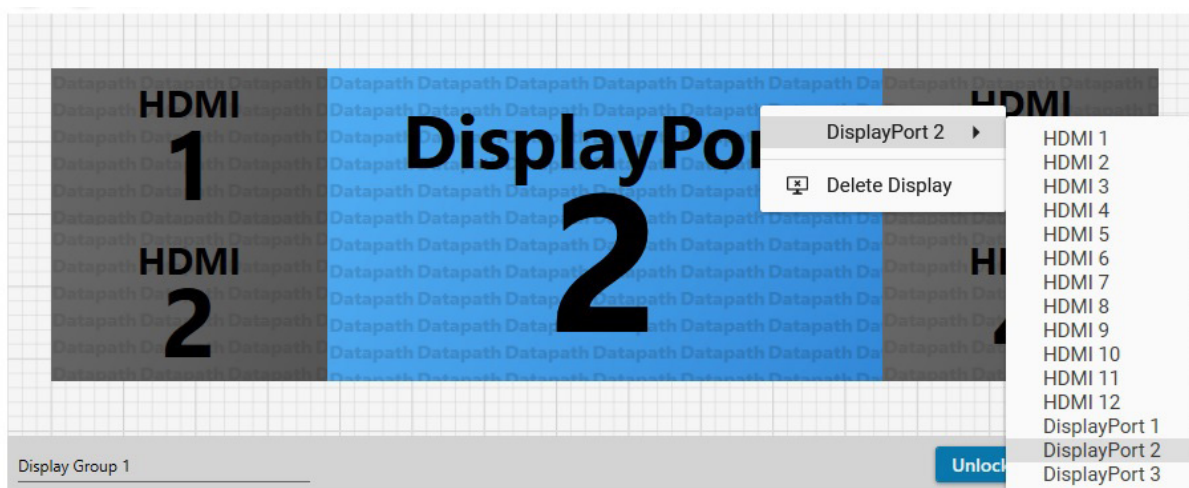

Import

Click on "Import" to import a previously saved layout. It should be noted that if the system the layout is being imported to does not have the hardware capability to run the layout, the imported layout will be rejected.

Once imported, onto the system, the layout can be edited in the "Manage Display Group" page.

Export

Click on "Export" to generate and export a layout as a .wall file. The layout can then be imported onto a another system.

When all outputs have been allocated either "Recommended" or "Custom" click on "Finish". You will then be prompted to save the changes to your video wall and restart your system.

6.3.13 Manage Display Groups

Display groups are collections of displays which cover different portions of your video wall. Display groups can be used to separate different areas of your video wall or use different groups to manage multiple video walls from a single controller.

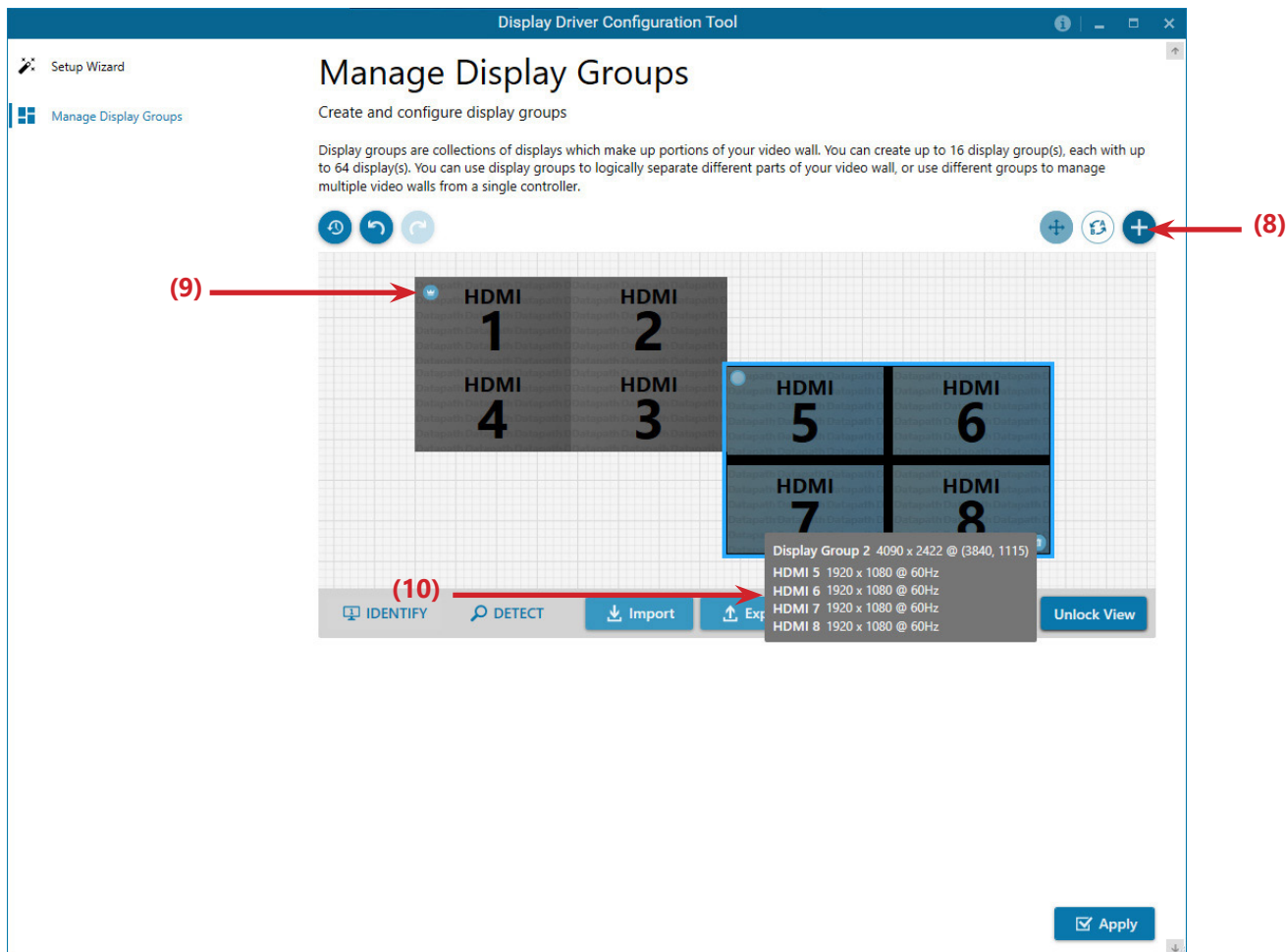

The “Manage Display Groups” dialogue allows you to edit current groups and create new groups. In the example above two groups have been created. Hover the mouse over each group **(10)** to display basic information about the display group:

- The group name
- Resolution
- Details of each output

The “Primary Display” can be assigned to any group by clicking on the icon **(9)** and toggling between each display group.

To create a new display group click on the “Create a new display group” icon **(8)** and the following dialogue is displayed.

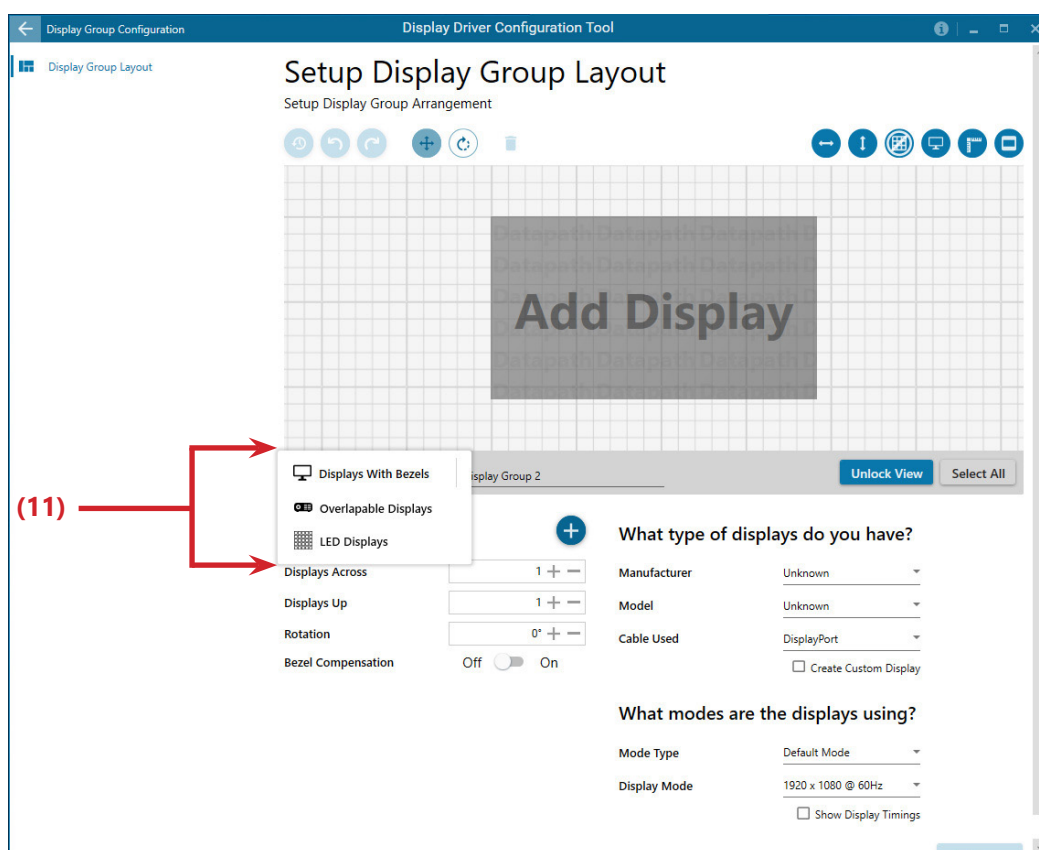

Create a new display group by first selecting the type of technology you will be using for your displays by clicking on the dropdown list **(11)**. Continue to create your new group layout in the same way you created your initial display group.

6.4 Opening WallControl 10 (Optional)

WallControl 10 is an optional video/display wall management software application specifically designed for Datapath Wall Controllers. WallControl 10 consists of two separate elements that work together to enable you to control the display wall, the Client (application) and the Server.

6.4.1 WallControl 10 Server

The WallControl 10 Server is used to display Vision/IP and application windows. The Server element of WallControl 10 needs to be installed on the machine to which your video wall is connected.

6.4.2 WallControl 10 Client

The WallControl 10 Client should be installed on the machine that has been identified to control the display wall. This could be any machine on the network including the machine driving the display wall. The application element of WallControl 10 is used to control the position, size and properties of each window displayed on the Server machine.

The WallControl 10 Client can be installed on systems running up to and including Windows 10 Operating Systems.



Start | All Programs | WallControl 10

The WallControl 10 Start Menu has four options, WallControl 10 Client, WallControl 10 Server, WallControl 10 Security Server and WallControl 10 Security Administration Client.

6.4.3 WallControl 10 - Server

The Server is the machine that drives your display wall, a Server can be located locally or via a network. WallControl 10 will automatically seek out and display all servers available to you. Each server can run multiple display walls depending on the version of WallControl 10 you have. Before opening the Client interface you may need to start the Server manually by clicking on it in the Programs menu. The WallControl 10 Client will only detect Servers that are running.



Start | All Programs | WallControl 10 | WallControl 10 Server

6.4.4 WallControl 10 - Client

WallControl 10 Client refers to the application that connects to the available servers.

6.4.5 WallControl 10 Security Server

The WallControl 10 User Rights Management application has a dedicated server that must be loaded prior to using the Security Application Client. Starting the WallControl 10 Server will load both the Server and Security Server.

6.4.6 WallControl 10 Security Administration Client

The WallControl 10 Security Administration Client allows Administrators to assign specific user roles on a wall by wall basis. Users are assigned Roles based on their Windows login. Roles can be structured to allow only specific tasks to be carried out on a wall using the WallControl 10 Client. For example, a user can be assigned a role allowing unrestricted access on one wall but assigned a role on another wall which only allows the launching of pre-determined layouts.

The application allows you to carry out the following User Rights Management Tasks:

- Import users from the Windows Active Directory into the application database
- Create and edit roles
- Assign permissions to providers, layouts and sources giving specific roles access to them
- Assign Roles to walls.

6.4.7 WallControl 10 - User Interface

Open the application by selecting WallControl 10 Client and the user interface will be launched.

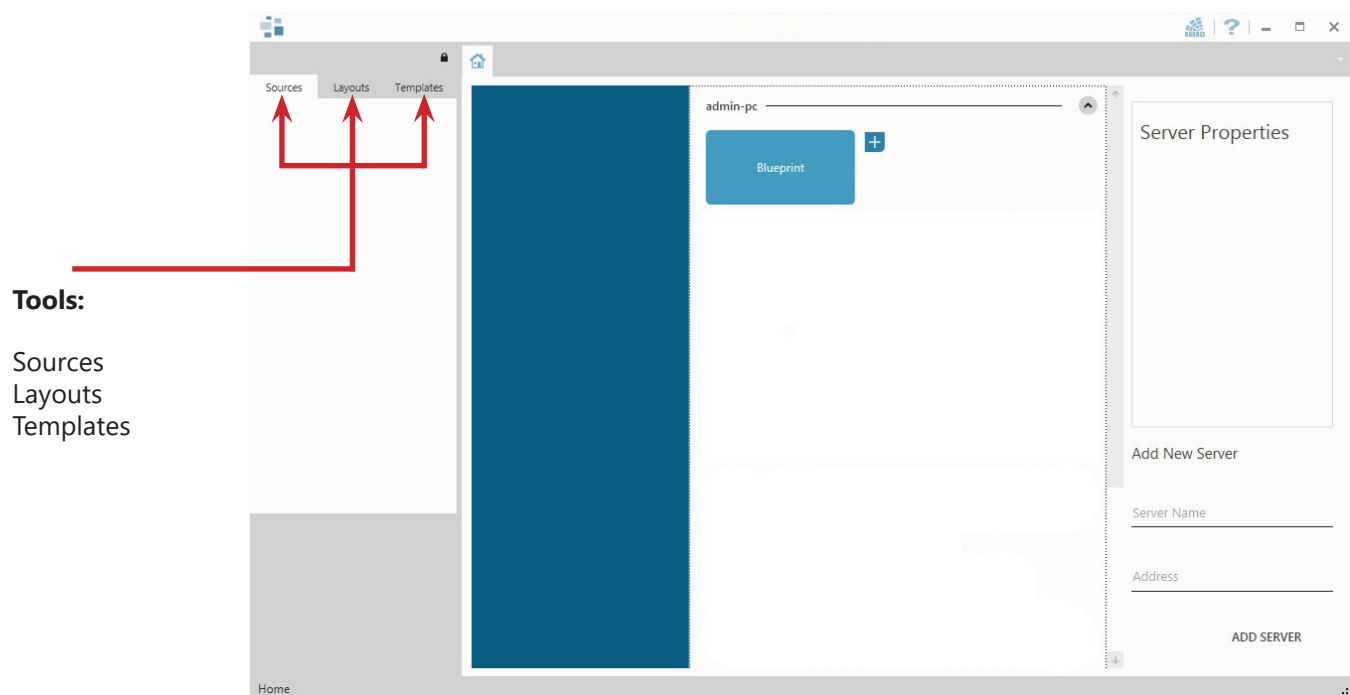

A detailed summary of WallControl 10 features can be found in Chapter 7, alternatively a comprehensive help file is available within the application.

Chapter 7 - Software

This chapter will cover:

- WallControl 10
- Wall Monitor
- Utilities

7.1 WallControl 10 (Optional)

WallControl 10 provides users with interface required to quickly and effectively manage content that includes video captures, IP streams and local applications. Users are able to place any input source on any part of the video wall using a simple drag and drop operation. Precise positioning of each piece of content can be achieved through the mouse and keyboard, or via the template tool.

The Template Tool allows users to not only place their own templates across an entire wall which evenly distributes content but WallControl 10 also allows users to apply a template to an individual window so multiple windows can be grouped together and moved as a single item.

WallControl 10 also introduces a tabbed interface that will allow a single user to seamlessly manage multiple video walls, user can see unique walls side by side to ensure things are running smoothly.

WallControl 10 allows multiple walls to be delivered by a single iolite system. Walls in separate areas of a building can be independently driven from a single location. Multiple walls can be easily set up using the WallCreator wizard and if required each wall can be assigned a unique set of sources or video resources.

7.2 WallControl 10 - Features and Tools

7.2.1 Layout Files

Save, recall and share specific desktop configurations using layout files.

7.2.2 Sources

Sources are grouped by type or by location in the Sources Tab. All sources can be allocated search strings which enables users to quickly find and display specific sources.

7.2.3 Templates

Templates are tools designed to assist in the creation of the layout of your display wall. Templates can be used to create visual displays over numerous screens to enable you to showcase specific content to target audiences. A number of pre-defined templates are available on the Template tab.

Three types of template are available:

Desktop Template - Allows you to create a template to cover the whole of your display wall.

Window Template - A template can be placed on top of a video window. The template can be dragged anywhere on the wall and re-sized.

Custom Templates - Design your own custom template and save it to the template library. It can then be used as a Desktop or Free Floating template.

7.2.4 Wall Manager

WallCreator enables you to create multiple walls from one single display wall. Each wall created can operate independently, having its own sources and templates.

7.2.5 Carousel

The Carousel function allows you to define a number of sources which a window will cycle through, allowing each input to be viewed in turn for a specified duration. The edit panel allows you to set the duration of each source in the Carousel cycle and create a buffer if required.

7.2.6 Vision and IP Window

Control over presenting captured video and IP camera streams on the display wall. Configure window properties including:

- Position and size of windows
- Aspect ratio enforcement
- Show window borders

7.2.7 Local Application Windows

Support for controlling applications such as Internet Explorer or Microsoft Powerpoint. Applications can be opened direct from the WallControl 10 Sources Tab.

7.2.8 Audio Support

Control digital and analogue audio content associated with specific Vision windows.

7.2.9 Multiwall (WallControl 10 PRO)

Configure a single system to drive multiple walls.

7.3 Opening WallControl 10



Start | All Programs | WallControl 10 - Server

Before opening the Client and Security Administration Client interfaces you will need to start the Server by clicking on it in the Programs menu. Starting the Server loads both the WallControl 10 Server and the WallControl 10 Security Server. The WallControl 10 Client will only detect servers that are running.



Start | All Programs | WallControl 10 - Client

The WallControl 10 - User Interface

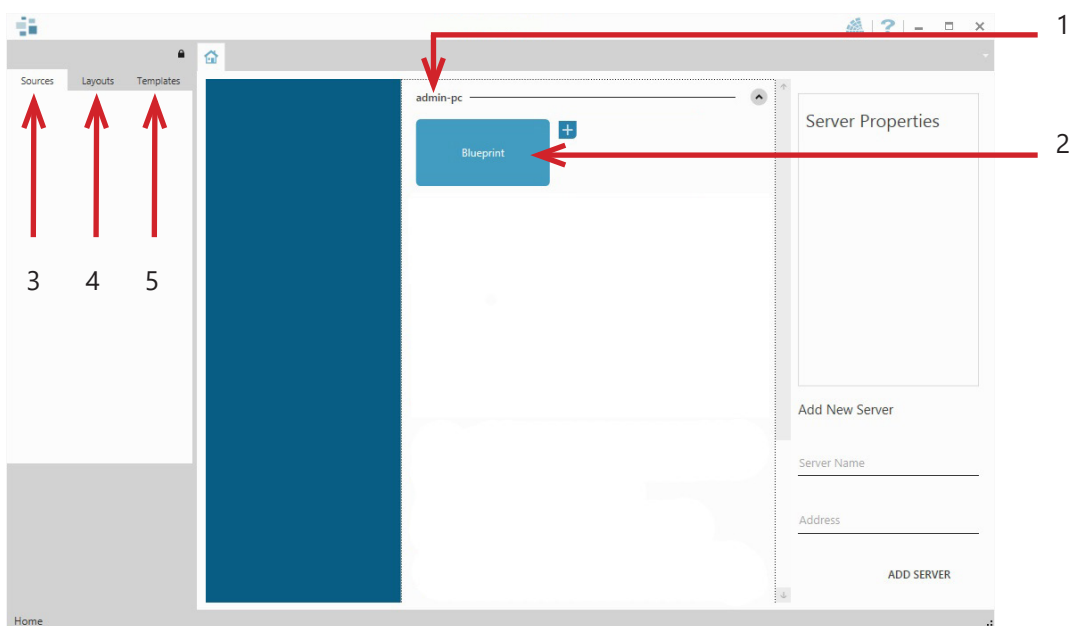

1	Indicates the server you are connected too.
2	A representation of the display wall(s) associated with the server.
3	Sources Tab - Displaying all the sources connected to the server for use on the display wall.
4	Layouts Tab - Used to save, recall and share display wall layout configurations.
5	Templates Tab - Use templates to assist in the design of specific display wall layouts.

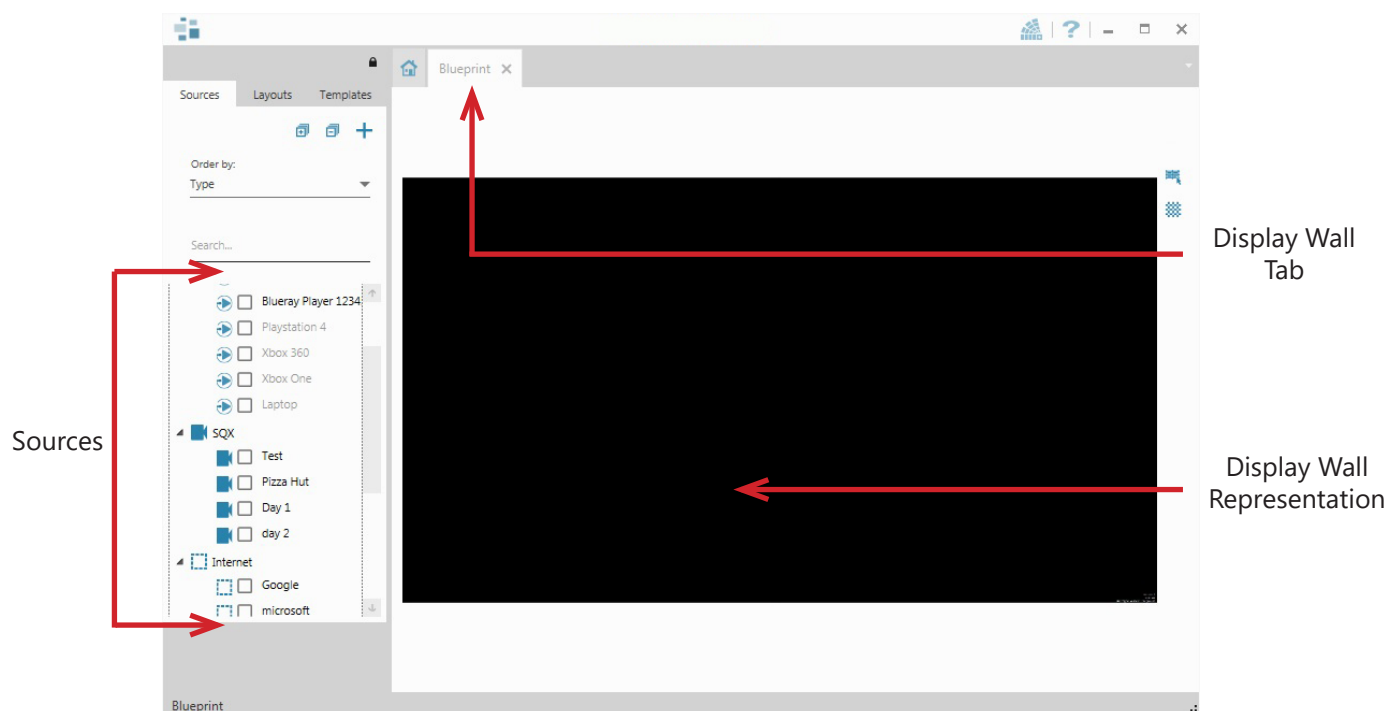

When opened, the display wall tab shows a live representation of the physical wall and the sources available to display on it. To place a source on the video wall, simply click on the required source in the sources tab and drag it onto the display wall representation.

The application help file contains information explaining how multiple sources can be selected, how to use and create templates and how to save, recall and share layout files.

The WallControl 10 - Security Administration Client (Only Available with WallControl 10-Pro)



Start | All Programs | WallControl 10 - Security Administration Client

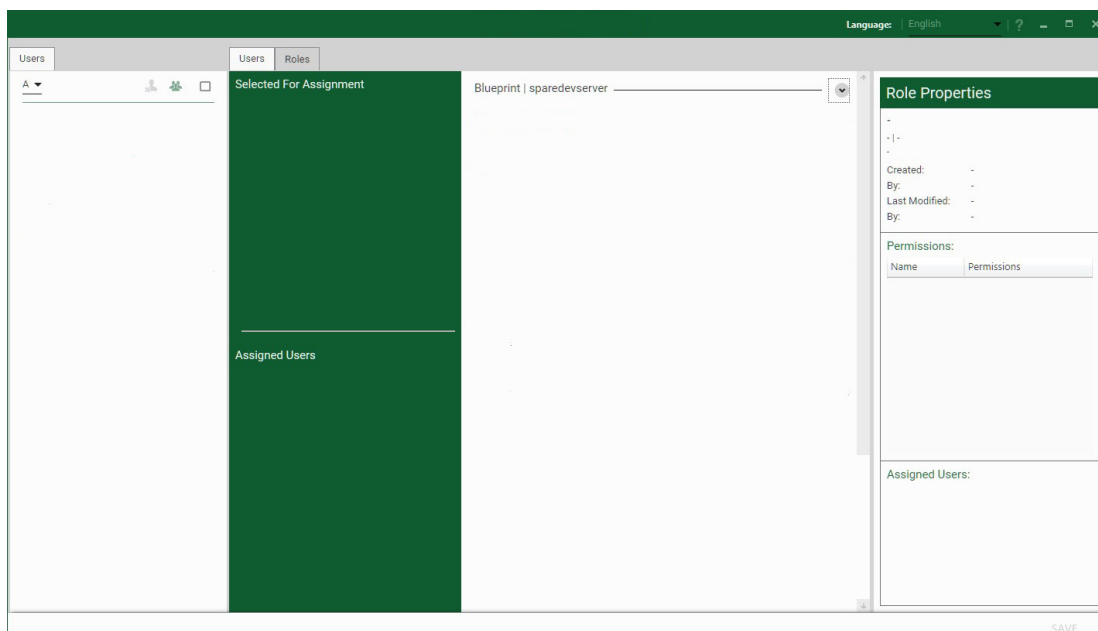

The WallControl 10 - Security Administration Client allows Administrators to assign specific users to roles on a wall by wall basis. For example, a user can be assigned a role allowing unrestricted access on one wall but assigned a role on another wall which only allows the opening of pre-determined layouts.

Prior to the Security Client being used for the first time, the SecurityOnOff.exe program must be run to enable security protection for the application. To run the SecurityOnOff.exe, ensure you are logged into Windows with Administrator Rights.

Locate and double click on the SecurityOnOff.exe file:

Program Files \WallControl 10\ Security Server\SecurityOnOff

A WallControl 10-Pro serial dongle must be inserted into a vacant USB port. If the dongle is removed or swapped, the Security Client will not open and an error message is displayed, therefore it is important the dongle is not removed.

The WallControl 10 Security Application help file contains information on how to:

- Import users from the Windows Active Directory into the database.
- Create and edit roles.

- Assign permissions to providers, layouts and sources giving specific roles access to them.
- Assign roles to walls.

The Security Administration Client has a built in help file to guide users through the process of setting up accounts, roles and permissions.

7.4 Wall Monitor (Optional)

The optional Wall Monitor software application enables you to monitor the temperatures and voltages of the following system components:

- Backplanes
- Capture Cards
- SQX Cards
- SBC
- CPU Cores
- Graphics Cards

Should any overheating or voltage surge be imminent within the system, the Wall Monitor application will alert the user via a pre-configured alarm.

When running, the Wall Monitor application can display a transparent floating icon which can be placed anywhere on the desktop.

Cursor tooltips are available throughout the application offering information and advice. Hover the cursor over different areas of the application to reveal the tooltips. The application also has a help file to assist you, click on any help button or press F1 on your keyboard to access the help files.

Left click the centre of the icon to open the application or right click to display the application menu.

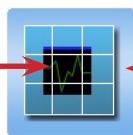

Wall Monitor Icon

Left click and hold on the border of the icon to move it around the desktop.

7.4.1 Monitoring System Components

Each of the system components listed above have built in temperature and/or voltage sensors which enables the Wall Monitor application to display any increase or decrease in voltage and temperature. The temperature and voltage ranges are graded as follows:

Green = Normal operating conditions

Amber = An indication that voltages or temperatures are operating outside of normal thresholds and if configured and alarm will activate.

Red = Indicates that the voltages or temperatures have exceeded the acceptable working thresholds and a system shutdown is imminent.

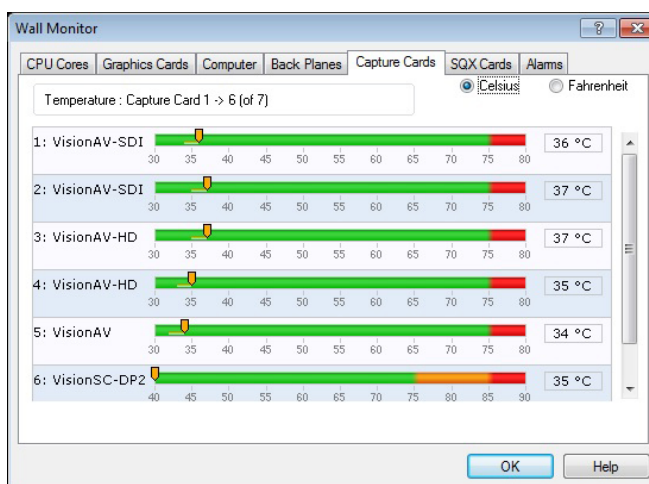

7.4.2 Wall Monitor Application Window

The Wall Monitor application window (above) is displaying the temperature of the capture cards in the system. To view different components, click on the relevant tabs. Temperatures can be displayed in either degrees Fahrenheit or degrees Celsius.

7.4.3 Configuring Alarms

Wall monitor allows you to configure three types of alarm to warn of impending problems:

System Buzzer - The system buzzer can be configured to determine the amount of time the buzzer will be audible up to a maximum of 5 seconds, an audio alarm is activated within the system. On some systems, speakers may have to be connected.

Email - Should you not be in the proximity of your system and email warning can be configured. An email is sent to a nominated email address giving details of impending problems.

On Screen - Text is displayed on screen to warn of impending problems with the system. The Wall Monitor icon adopts an amber border when the alarm is issued.

7.4.4 Current Status

At any time you can check the current status of the monitored components by selecting **Show Current Status in Browser** from the **Application** menu. This will display a browser window, similar to the following:

Summary of the status of all monitored devices



The browser window shows the 'Current Status' page. It contains a summary table of device status and a detailed table for CPU Cores.

Device Status	Total	Green	Amber	Red
CPU Cores	4	4	0	0
SBC	1	1	0	0
GPUs	1	1	0	0
Capture Card	7	7	0	0
BackPlanes	3	9	0	0

CPU Cores	Minimum	User Min	Current	User Max	Maximum
Core 1	N/A	N/A	42 °C	90 °C	92 °C
Core 2	N/A	N/A	39 °C	90 °C	92 °C

7.5 Vision Application (Optional)

When purchased separately, Vision capture cards are supplied with a powerful software application for configuring the format of input sources and displaying the data.

7.5.1 Video Streaming

DirectShow drivers for WDM Streaming driver supports the following applications, to encode, record and stream video over networks or the Internet:

- Microsoft Media Encoder®
- VLC
- VirtualDub
- Any other DirectShow encoding software

For streaming applications, Vision cards can be used with Windows Media Encoder to compress and stream captured video. To replay the video, use Windows Media Player.

Any application compatible with Windows DirectShow technology can use Vision capture cards due to their built-in WDM support.

7.5.2 Vision Software Capabilities

Timestamp support for streaming synchronisation:

- Synchronisation of multiple inputs across multiple cards
- Synchronise systems using network clock synchronisation
- For edge blending and other applications

Flexible and configurable EDID Management:

- Allows programming of custom EDID parameters for capture cards

Low Input to Output Capture Latency.

DMA to third party graphics vendors back and front buffers via Direct3D:

- Compatibility with AMD DirectGMA
- Compatibility with Nvidia GPUDirect

User Mode filter for source selection:

- Enables cropping support in DirectShow on all inputs
- Supports Start and Stop trigger interface on all Vision inputs

Datapath Unified Vision Driver:

- Frame sync and time stamping

- DirectShow interface
- The RGBEasy API for advanced audio and video control
- Fully integrated for use with Datapath Wall Control software for video wall applications

7.5.3 MultiStream

Datapath's MultiStream feature is available on all Datapath capture cards and enables multiple, independently formatted video streams to be set up in parallel.

Each stream can be formatted completely independently and individual selection of resolution, colour space and cropping region can be set for each stream. This maximises bandwidth utilisation of the capture card and PCIe interface, and also simplifies development tasks for application developers who do not need to implement video stream reformatting separately.

7.5.4 Vision Application Overview

The application displays the connected source in a window; it has the following features:

- Scales the data to fit in the window
- Ability to set up sources accurately (settings automatically saved)
- Save a single frame to a file in one of the following formats: BMP, JPEG, GIF, TIFF, PNG
- Print a single frame
- Maintain the aspect ratio of the displayed captured data
- Cropping
- Display text over the data (on-screen display)
- Command line interface
- HDCP supported (not supported in SQX encoding)
- Help file documenting all features

7.5.5 SoftSQX

SoftSQX uses the processing power of the CPU to decode IP streams. SoftSQX also includes an IP transport stack within Windows for RTSP delivery. The SQXEasy SDK is transparent to both ActiveSQX and SoftSQX. If no ActiveSQX hardware is available, or ActiveSQX resources are full to capacity, the Wall Control SQX software will 'roll over' to SoftSQX for decoding networked video sources when on the same domain.

SoftSQX is included in as part of Wall Control-SQX. In addition to using the Wall Control-SQX, users are able to take advantage of SQXEasy to create their own applications (in place of Wall Control-SQX) to leverage the CPU decoding, with or without an ActiveSQX. To use SoftSQX you require an ImageDP4 in the system.

Streaming Methods	Multicast & Unicast support
Streaming Codecs	H.264 (Mpeg4 Part 10 AVC), VC-1, MPEG2 Part 2
Streaming Containers	MPEG4 part 1, MPEG2-TS, WMV, MOV
Streaming Protocols	RTSP Only (For additional streaming protocols an ActiveSQX decoding card will be required)
Decode Density	Approximately 8 streams of 1920x1080p 30 frames per second can be decoded depending on Profiles and Levels used.
De-interlacing	Not Supported
Stream Authentication	Basic & Digest Stream Authentication
H.264 Profiles	Constrained Baseline Profile (CBP) / Main Profile (MP) / High Profile (HiP)
H.264 Levels	Level 3 / 3.1 / 4 / 4.1 / 4.2 / 5 / 5.1 / 5.2
Colour Format	NV12 4:2:0
Hardware Requirements	SoftSQX requires a system that includes a Datapath Graphics Card

7.6 Software Utilities

Datapath provides a group of software utilities designed to assist you to fine tune your system for specific individual system requirements. All the software utilities can be found on the Recovery Media that was shipped with your system, alternatively, you can download the most up-to-date versions from the Datapath website.

7.6.1 Desktop Utility

Used to define a desktop resolution which can compensate for display bezels or projector overlap.

7.6.2 Custom Mode Utility

A utility for defining custom display timings for video modes not available in the display driver or EDID.

7.6.3 Diagnostic Tool (diagtool)

A diagnostic tool that gathers information to assist in diagnosing problems with hardware and software configurations.

Information is gathered and compressed into a zip file for onward transmission to the Datapath Support Team.

7.6.4 PCICFG Tool

A diagnostic program that prints out the PCI configuration information. Note, this tool must be run from either a USB or MSDOS boot disk, it cannot be run from Windows.

7.6.5 Sleep Utility

Designed to generate a pause within a script. This can be used when sequencing the loading of files or application windows.

Chapter 8 - Technical Support

8.1 Technical Support

Registered users can access our technical support using email and the Support Enquiry Form on our website, usually with a response within 24 hours (excluding weekends).

8.1.1 Email

Send an email to support@datapath.co.uk with as much information about your system as possible. To enable a swift response our support team will need to know the following details:

- Specification of the PC - including processor speed.
- Operating system.
- Application Software.
- Datapath Hardware/Software.
- The serial number of the iolite 12i - located on the chassis label
- The exact nature of the problem - please be as specific as possible.

Please quote version and revision numbers of hardware and software wherever possible.

8.1.2 Support Procedures

During the support process you may be asked by one of our support staff to carry out certain tasks and procedures to assist them in solving any problem you may encounter. Details and up to date instructions can be found in the support section of the Datapath website.

Chapter 9 - Maintenance

9.1 Filter Maintenance

The system filter is an integral part of the iolite 12i and as such it needs to be maintained correctly. Failure to maintain the filter can result in the system overheating and causing it to shutdown unexpectedly. In normal operating conditions, the filter should be removed and cleaned every 3 months. However, this 3 month period is a guide only and it can be increased to every 6 months or decreased to one month depending on the levels of dust in the environment the system is operating in.

It is recommended that the condition of the filter is checked at regular intervals.

Note:

Failure to maintain the system filter could result in damage to your system and invalidate the warranty.

9.1.1 Removing the Filter

Power down the system and remove the mains cable from the rear panel.

The system filter is housed within the mesh cover on the front panel. Gently pull the mesh cover away from the front of the main unit and remove the filter from within by unscrewing the two retaining screws.

The filter should only be removed by a trained technician.

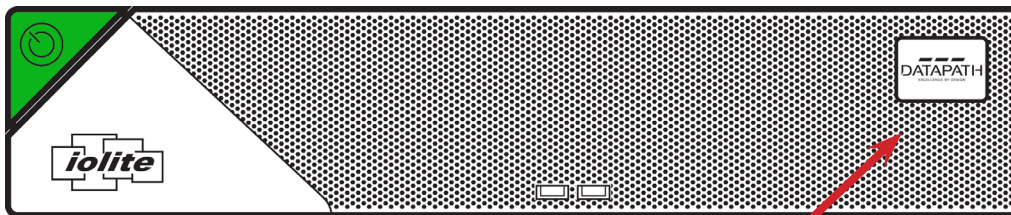

Remove the filter from the rear of the mesh cover to clean.

Shake the filter to remove any dust particles, this should not be done in close proximity to the system to avoid dust ingress. Ideally, the filter should be cleaned using a vacuum cleaner.



Note: The filter should never be immersed in water or any other cleaning liquid.

For advice on replacement filters, please contact Datapath Ltd.

Chapter 10 - Environmental

10.1 Certification and Compliances

10.1.1 CE



EU- Class A Declaration of Conformity

Datapath Ltd declares that this product complies with the essential requirements and other relevant provisions of Directives 2014/30/EU, 2014/35/EU and 2011/65/EU.

A copy of our Declaration of Conformity is available on request:

Datapath Ltd
Bemrose House
Bemrose Park
Wayzgoose Drive
Derby, DE21 6XQ
United Kingdom

10.1.2 FCC

These devices comply with part 15 of the FCC Rules. Operation is subject to the following two conditions: (1) These devices may not cause harmful interference, and (2) these devices must accept any interference received, including interference that may cause undesired operation.

This equipment has been tested and found to comply with the limits for a Class A digital device, pursuant to part 15 of the FCC Rules. These limits are designed to provide reasonable protection against harmful interference when the equipment is operated in a commercial environment. This equipment generates, uses and can radiate radio frequency energy and, if not installed and used in accordance with the instruction manual, may cause harmful interference to radio communications. Operation of this equipment in a residential area is likely to cause harmful interference in which case the user will be required to correct the interference at their own expense.



Caution. Changes or modifications to the equipment not expressly approved by the party responsible for compliance could void the user's authority to operate the equipment

10.1.3 Disposal

At the end of life all Datapath products should be disposed of as per local laws and regulations dictate. In the UK contact Datapath to arrange disposal. Our WEE registration number is WEEE/AA0005ZR.

Chapter 11 - Specifications

This chapter will cover:

- Dimensions
- Technical specification of the iolite 12i

11.1 Dimensions

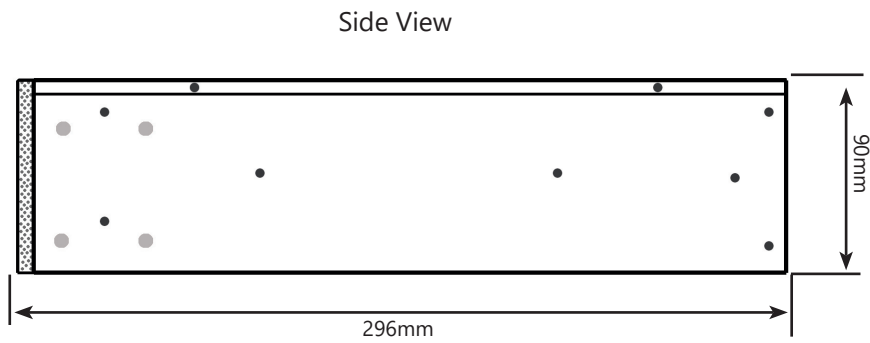
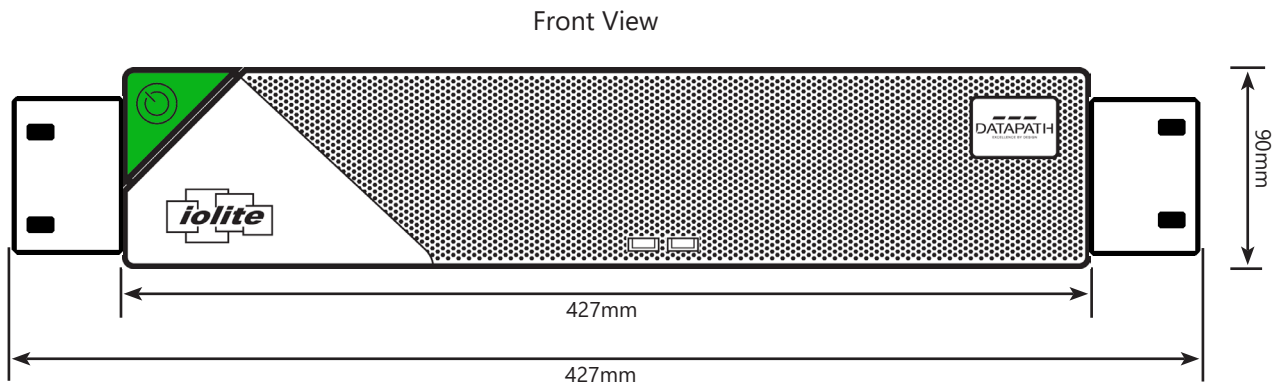

11.2 Technical Specification - iolite 12i

Motherboard Specifications: COTS mini ITX HDMI, DisplayPort Control Screen outputs
Outputs: 12 x integrated HDMI outputs (1920x1080p @60fps) 3 x integrated DisplayPort 1.2 outputs (3840x2160p@60fps)
Expansion slots: 2 x PCI x4 Gen3
USB Connectivity: 4 x USB 3.0 ports (Rear) 2 x USB 2.0 ports (Front)
Ethernet: 2 x Intel Gigabit LAN
WiFi: Optional (via USB adapter)
Processor Options: Standard - Core™ i5 Optional Upgrade - Core™ i7
System Memory Options: Standard - 8GB DDR4 Optional Upgrade - 16GB DDR4
Hard Drive Options: Standard - Single 128GB SSD Optional Upgrade - 1TB HDD
Operating System Windows 10 LTSC
Power Supply: ATX 250 watts
Dimensions: Length - 296mm Height - 90mm Width - 427mm
Weight: 10 - 15kg (unpacked) 15 - 20kg (shipping weight)
Compliance: CC, CE, FCC

Chapter 12 - Warranty

12.1 Warranty Statement

Datapath provides a return to manufacturer warranty on all its products for a standard 36 month period. It is important that RMA procedures are followed prior to products being returned as often issues can be resolved quickly without the need for products being returned.

12.2 RMA Returns Policy

If your Datapath product is not working as you expect, we recommend that you contact Datapath in the first instance for support, since many issues that may first appear as hardware faults, are actually installation or set-up problems and can normally be resolved without having to ship any hardware back to us. This route is therefore often the quickest, easiest and cheapest way of solving the problems that you are experiencing. Please email support@datapath.co.uk including as much detail regarding the failure as possible (for example: system description, signal types, input or output resolutions and any other relevant background information).

It is essential for you to know the serial number of the product(s) when contacting us.

If it appears that the fault is most likely to be hardware related, please email rma@datapath.co.uk stating the serial number and as much additional information regarding the nature of the failure as possible. Detailed explanation of the fault will help us to better identify the problem and will direct additional focused testing if necessary. We will then issue an "RMA Number" to you.

At the time that the "RMA Number" is issued we will inform you of the warranty status of the product and the cost of the repair, if appropriate - see paragraph (b) below. The product should then be returned, at your cost, to Datapath Ltd following the steps below.

There are 4 possible scenarios when a product is returned to us:

- (a) The product is in warranty and is either found to be genuinely faulty or no fault is found. In these cases, the product will be repaired as necessary, or replaced by a new or previously repaired product, and returned to you at our cost.
- (b) The product is out of warranty and is found to be faulty. The product if possible will be repaired or replaced at fixed cost, as stated in the RMA authorisation email. To cover this payment, you will be required to either provide a Purchase Order or Credit Card details, when the product is returned to us. (However, we will not issue an invoice or charge the credit card until the repair has been completed and is about to be returned to you)
- (c) The product is in warranty but is found to be damaged by misuse. This will be treated as (b) above.
- (d) The product is out of warranty and is obsolete. In the unlikely situation that the product can be neither repaired nor replaced, because some of its components are obsolete and we have no swap-out stock left, then the product will either be returned to you, or disposed of at your request, with no charge.

PLEASE NOTE: Datapath will not accept responsibility for the safety, integrity or security of any programmes, data or other content held on hard drives or any other type of rewritable media which is sent to us either separately or as part of any equipment returned to us for repair or for any other purpose. Customers are advised to take back-ups of anything that they deem to be valuable or important before returning the equipment to us and anything which is confidential should be erased from the media before it's returned.

Once the RMA Number has been issued, you need to raise your Purchase Order, or supply your credit card details, and return the product to: Datapath Ltd, Bemrose House, Bemrose Park, Derby DE21 6XQ, United Kingdom - securely packed and with the RMA Number clearly displayed on the outside of the box. To prevent unnecessary carriage and handling please only send back products or accessory items you believe to be faulty.

In the case of paragraph (c) , the fixed charge will be levied after we have seen the product and identified the misuse. In this case we will request you to issue a purchase order or provide credit card details before any repairs are completed.

Our policy is to return the repair (or swap-out) to you within 10 UK business days of receipt.

Chapter 13 - Advanced Users

This chapter is aimed towards advanced users and covers the following:

- Installing CODEC Packs to play video
- Updating Firmware
- System Recovery

13.1 Installing CODEC Packs to Play Video

DGCPlay utilises the DirectShow codecs installed on the computer to playback a video file. A standard installation of Windows includes codecs for playing WMV files, plus some AVI and MPG files. Many video files require additional 3rd party codec files.

For many of AVI and MPG formats the open source ffdshow package will contain codecs which will allow playback using DGCPlay. ffdshow is available from:

<http://ffdshow-tryout.sourceforge.net>

MOV files are supported through QuickTime. By default QuickTime is not available through DirectShow. With additional software it is possible to make QuickTime video files available however. There are a number of codecs which do this, for instance:

http://www.codecguide.com/download_kl.htm

Datapath do not provide any warranty or assurance that these examples will be suitable for commercial use. We simply list them as an example of those available through 3rd parties. Before deployment we advise that any of the above, and any other codec selected, is thoroughly evaluated to confirm their suitability.

13.2 Firmware Updates

Firmware updates, if required, are automatically carried out when the Driver Install is updated. Bear in mind that firmware updates can take up to 10 minutes to complete.

During the upgrade process, the iolite 12i DisplayPort (1-3) and HDMI (1-12) output connectors become inactive and only the motherboard control screens are operational to run the upgrade. The process will start automatically once the user is logged into the system.

Once the upgrade is complete, the user is prompted to restart the system.

13.3 Restoring Windows 10

It is strongly advised that a Restore USB Flash Drive is created which can then be used to restore the operating system should any serious problems arise.

13.3.1 Creating a Windows 10 Restore USB Flash Drive

To create your Restore USB Flash Drive you will need a USB memory stick with a minimum capacity of 16GB. It is recommended that once your restore flash drive has been created, it is stored in a safe place accessible to personnel who may be required to restore the system.

You will need to boot into the Windows Restore portal to begin the process of creating your Restore USB Flash Drive.

Switch on your machine and when the boot messages display the “**Choose an operating system**” screen, use the cursor keys to select “**Windows Restore**” as shown in the following dialogue.

It should be noted that the dialogue is only displayed briefly, approximately 3 seconds.

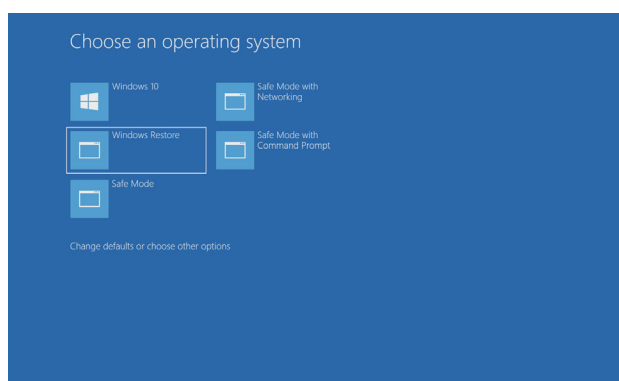

This will lead you to the Windows 10 Restore Menu as shown below:



Click on the “**Create Restore Media**” icon then insert the USB flash drive into a vacant USB slot (min capacity 16GB).

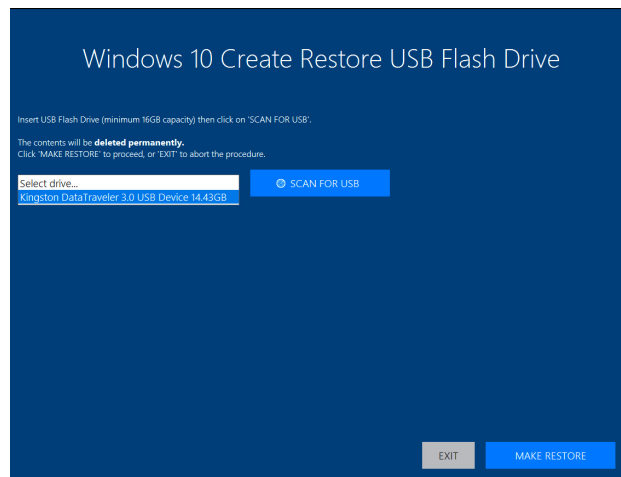

It should be noted that any data currently stored on the USB Flash Drive will be deleted permanently during this process.

Click on **"SCAN FOR USB"**.

The application will now scan the system USB ports to detect your USB flash drive. Once the flash drive has been discovered, it will appear in the **"Select Drive"** dropdown list. Select the flash drive you wish to use from the list and click on **"MAKE RESTORE"**.

Once the Windows 10 Restore USB Flash Drive has been created a **"Build Complete"** dialogue is displayed:

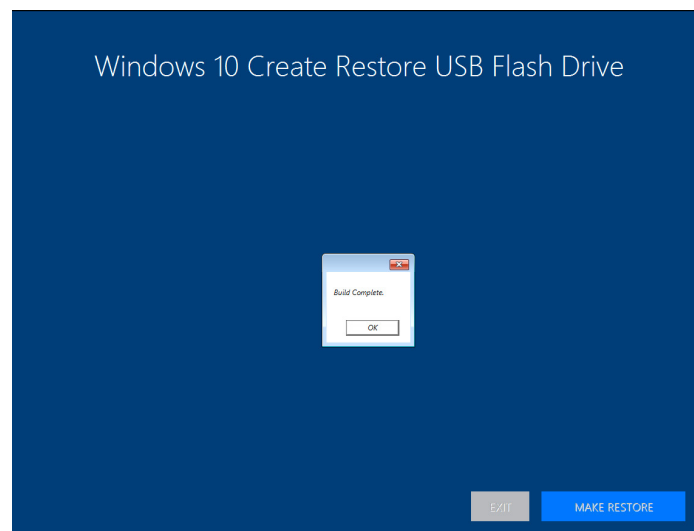

Click on **"OK"** to complete the process.

13.3.2 Restoring the Windows 10 Operating System

To restore the Windows 10 Operating System you will need to boot the system from your **"Restore USB Flash Drive"** or the **"Restore Partition"** on your hard drive. If restoring from the USB Flash Drive, place it into any vacant USB port prior to turning on the system.

To restore from the USB Flash Drive, turn on the system and booting process commences, press the F11 key until the **"Select Boot Device"** dialogue is displayed. Select the Boot device (Restore USB Flash Drive). If available, it is recommended the UEFI device is selected. Once the Boot Device has been selected, click **"OK"** and wait until the **"Choose an operating system"** dialogue is displayed.

If you are restoring the Windows 10 Operating System from the **“Restore Partition”** on your hard drive, turn on the system and wait until the **“Choose an operating system”** dialogue is displayed.

When the **“Choose an operating system”** dialogue is displayed select **“Windows Restore”** as shown below:

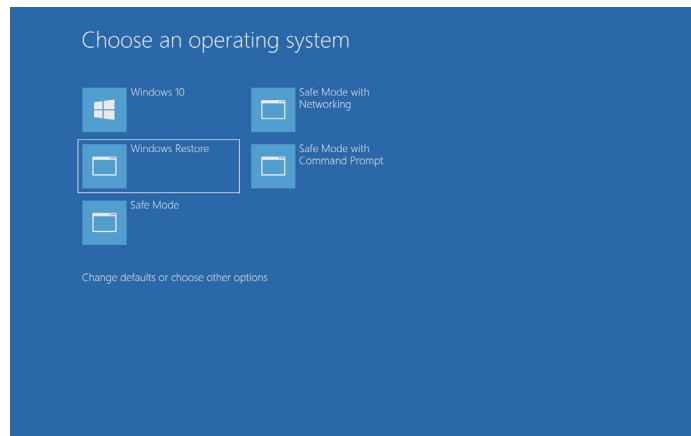

The **“Windows 10 Restore Menu”** dialogue will then be displayed.



Click on the **“Restore Windows”** icon and the **“Windows 10 Installation”** dialogue is displayed.



If restoring the Windows 10 operating system using a USB Flash Drive, a check box is displayed in the bottom left corner of the dialogue box. The "**Create Restore Partition**" should be selected. This will create a new Restore Partition on the hard drive.

Click "**Continue**" and you will be prompted to accept the Windows 10 licence Agreement. Click on "**ACCEPT**" to continue with the installation.

Once the installation is complete the system will reboot and the out-of-box experience will commence, you will be required to configure the language and keyboard as if using the system for the first time.

13.5.3 Install Display Drivers and Software

Once the Windows configuration process is complete the Display Drivers need to be re-installed and if required, the Wall

Control application software. The Display Drivers and WallControl 10 software can be found in the **Support Tile** on the **Start Menu**. For the latest drivers and software go to www.datapath.co.uk

Index

A

Add Groups 33
Application Tools 30
Assign permissions 15, 43
Assign roles to walls 15, 43
Associated Output/Input Cards 19

C

Cables 32
Client 40
Create and edit roles 15, 43
Create Restore Media 57
Creating a Windows 10 Restore USB Flash Drive 57

D

Datapath Display Configuration Tool 27
DDCT 27
Desktop Utility 48
Detect servers 40
Diagnostic Tool 48
Dimensions 53
Disclaimer 5
Display Groups 35
Displaying Video Captures 25
Display Mode 32
DisplayPort Outputs 24
Display Setup 9
Display Technology 28
Disposal 51

E

Email Support 49
Enable X Axis 30
Enable Y Axis 30
Ethernet Ports 20

F

FCC Rules 51
Firmware Updates 56
Fonts and Symbols 16

G

Graphics Card 44

H

Hard Drive Options 53
HDMI Outputs 24
Help file 15, 43

I

Initial Inspection 18
Initial System Boot on Delivery 26
Install Display Drivers and Software 60
Installing CODEC Packs 56

K

Keyboard 6

L

Language Pack 26
Layouts Tab 41

M

Manufacturer Warranty 54
Motherboard Specifications 53
Move displays 30
MultiStream 47

N

Network Security 22

O

On/Off 25
Opening WallControl 10 (Optional) 37
Overheating 44
Overview 19

P

PCICFG Tool 48
Power Cables 24
Powering up the System 8
Primary Display 31
Product Datasheets 19
Product End of Life 51

Q

Quick Start Guide 6

R

Range of Datapath Products 19
Removing the Filter 50
Restoring the Windows 10 Operating System 58
Returns Policy 54
RMA Number 54

S

Scan for USB 58
Security Administration Client 14, 42
SecurityOnOff.exe 15, 43
Security Server 40
Set up Windows® 10 26
Show Current Status 45
SoftSQX 47
Sources Tab 41
SQX 17
SQXEasy 48
Streaming Codecs 48
Streaming Protocols 48

Summary 19
Support Procedures 49
Symbols 16
System Backup 27
System Buzzer 45
System Filter 50
System Memory Options 53

T

Technical Specifications 52
Temperature and Voltage Ranges 44
Templates Tab 41
Terminology 17

U

Utilities 48

V

Video Streaming 46
Vision Application 46
VisionAV 19
VisionAV-HD 19
VisionAV-SDI 19
VisionSC-DP2 19

W

Wall Control 13
WallControl 10 - Client 37
WallControl 10 Security Server 37
WallControl 10 - Server 37
WallControl 10 Server 40
Wall Control-red Features 38
Wall Control-SQX 48
Wall Monitor Application 45
Wall Monitor Software 44
Wall Naming 31
What display module are you using? 32
Windows 10 Restore Menu 57
Windows Restore 57
Wiring 34