



8K Video Server

SR-8450

Instruction Manual

Ver. 1.20























ASTRODESIGN, Inc.



Safety precautions (Always observe)

Always observe the following precautions. Failure to do so can result in fires, electric shock, serious injury or death, and damage to property.

Warning indications and meaning of symbols

This manual uses the following warning indications and symbols. Before reading this manual, make sure that you understand the meaning of these indications.

Warning	Symbols														
<p> Warning</p> <p>Failure to heed this warning may lead to an accident resulting in death, serious injury, etc. due to a fire or electric shock.</p>	<ul style="list-style-type: none"> • Caution symbols <table border="0"> <tr> <td></td> <td></td> <td></td> <td></td> </tr> <tr> <td>Fire</td> <td>Electric shock</td> <td>High temperatures</td> <td>Finger injury hazard</td> </tr> </table> • Symbols for forbidden actions <table border="0"> <tr> <td></td> <td></td> </tr> <tr> <td>Forbidden</td> <td>Do not disassemble</td> </tr> </table> • Symbols for required actions <table border="0"> <tr> <td></td> </tr> <tr> <td>Required actions</td> </tr> </table> 					Fire	Electric shock	High temperatures	Finger injury hazard			Forbidden	Do not disassemble		Required actions
															
Fire	Electric shock	High temperatures	Finger injury hazard												
															
Forbidden	Do not disassemble														
															
Required actions															
<p> Caution</p> <p>Failure to heed this caution can lead to injury due to electric shock or other accidents, and damage to the unit and other property in the vicinity.</p>															

 **Warning**  

About Handling the Unit

 **Forbidden**

Do not throw or subject to strong impacts. Doing so may cause a malfunction, cracking, heat generation, or fire.

Do not use where there is a risk of fire or explosion. Doing so may result in fire.

Do not allow water or foreign objects inside the unit. Doing so may cause a fire, electric shock, or accident. If liquid or foreign objects should get inside, immediately turn the power off and contact your dealer or an ASTRODESIGN, Inc. sales representative.

 **Do not disassemble**

Do not disassemble, repair, or modify. There are high-voltage components inside the unit. There is a risk of a fire or an electric shock, burn, or other injury, and doing so may cause a malfunction.

 **Required actions**

If thunder is heard during outdoor use, immediately turn the power off, unplug the power cord from the power outlet, and move the unit to a safe place.

Failure to do so may result in fire and electric shock due to lightning.

About Handling the Power Cord

 **Forbidden**

Do not damage the power cord. Damage to the power cord may result in fire and electric shock.

- Do not modify the power cord.
- Do not forcibly bend the power cord, bundle or tie it, or place heavy objects on it.

Keep the power cord away from heaters and do not allow it to become hot.

 **Required actions**

Always grasp the plug when unplugging the power cord.

About foreign matter

 **Forbidden**

Do not spill liquids inside or remove flammable objects or metals. If you use it as it is, it may cause fire, electric shock, or malfunction.

Caution

About Handling the Unit



Forbidden

Do not use in the following environments.

Doing so may cause a malfunction.

- Location where the ambient temperature is outside the range of 0 to 40°C
- Location where the ambient humidity is outside the range of 20 to 80% RH
- Location near an air conditioning unit where there may be sudden temperature changes or condensation
- Location subject to direct sunlight
- Location with corrosive gases or very dusty location
- Location where strong magnetic fields are generated
- Location where the unit may be splashed with water, oil, chemicals, etc.
- Location where vibration is transferred through the floor
- Unstable location
- Locations above an altitude of 2000m
- Tropical area

Do not place objects around this device

If the ventilation holes or fan parts are blocked, this device may fail.

About the Power Supply



Forbidden

Do not turn the power back on immediately after turning it off.

Doing so may cause a malfunction.

About Strong Impacts



Forbidden

Do not drop the unit or subject it to impacts.

If the unit is subjected to impacts, there is a risk of a malfunction. Take sufficient care when moving the unit.

About the Liquid Crystal Display (LCD)



Forbidden

Do not touch any liquid (liquid crystals) that may leak from the LCD panel.

- If the LCD panel is inadvertently damaged, liquid (liquid crystals) may leak from the panel. Keep the liquid away from your mouth and skin and do not inhale the vapors.

If any liquid should contact your mouth or eyes, wash away immediately with water.

Furthermore, if any liquid should adhere to your skin or clothing, wipe them off with alcohol or the like and then wash away with soap. Your skin or clothing may be damaged if liquid crystals are left adhered.



Finger injury hazard

Be careful of glass shards from a broken LCD panel.

If the LCD panel is inadvertently damaged, take care not to cut your hands on glass shards.



Required actions

Care in handling of the LCD panel.

- Do not wipe with benzene or thinner.
- Do not apply water (or salt water).
- Do not leave exposed to ultraviolet rays for long periods.
- Do not use in an environment subject to condensation.
- Do not strike, bump, or otherwise subject to impacts.
- Do not disassemble.

If the Unit Malfunctions or Trouble Occurs

Stop using the unit immediately, unplug the power cord, and contact your dealer or an ASTRODESIGN, Inc. sales representative.

Before you use

At first

Thank you very much for purchasing the 8K Video Server SR-8450.
This instruction manual (hereinafter referred to as "this manual") explains how to use the SR-8450 and the precautions for use.
To ensure proper use of the SR-8450, be sure to read this document before use.
Also, please keep this book in a safe place.

About terminology

For the sake of simplicity, some terms in this document may refer to:

project	Notation in this document
8K Video Server SR-8450	This device
Remote controller RB-8428	remote controller
Recording Media	SSD

About bundled items

The items included with this device are as follows. If there is anything that is missing or damaged, please contact the dealer or the sales department of ASTRODESIGN, Inc.

Name		product	quantity	remarks
SR-8450	8K video server	SR-8450 main unit	1	
		AC power cord	2	15A
		75Ω Termination Resistor	1	
		Instruction manual	1	This book
RB-8428	Remote Controller	RB-8428 main unit	1	
		AC power cord	1	7A
		BNC cable for remote controller*1	1	3m

*1: If you would like to request BNC cables for remote controller of different lengths, please contact the Business Division of ASTRODESIGN, Inc.

! Important

- Please be sure to use the included accessories. Using anything other than accessories may cause a malfunction.
- Repeated recording and erasure may degrade the performance of the SSD. In that case, the performance of the SSD may be improved by running Disk Format of the SSD on the main unit.
- Before using this device, be sure to perform a recording test to ensure that it is recorded normally. If by any chance the recording is not recorded due to these defects while using this device, SSD, or externally connected device, we can not compensate for the recorded contents. Thank you for your understanding.
- Please be sure to check the operation before using this device. We will not compensate for loss of business opportunities due to breakdowns or other reasons, regardless of whether it is within the warranty period or after the expiration of the warranty period. Thank you for your understanding.

Contents

Safety precautions (Always observe)	2	Chapter 4 Operation from the remote controller .	23
Warning indications and meaning of symbols.....	2	4.1 Name and function of each part of	
If the Unit Malfunctions or Trouble Occurs	4	the remote controller.....	23
Before you use	5	4.2 Operations about simultaneous	
At first.....	5	recording playback.....	25
About terminology.....	5	4.2.1 Live mode.....	25
About bundled items.....	5	4.2.2 PlayBack mode.....	25
Contents	6	4.2.3 Jog Mode.....	27
Chapter 1 About this device	8	4.2.4 Full end of recording.....	27
1.1 summary	8	4.3 Working with Mark Points	28
1.2 Features of this device.....	8	4.4 Operations about Goto TC.....	28
1.3 Names and functions of each part.....	9	4.5 Clip operations	29
1.3.1 This device SR-8450	9	4.5.1 Page-BANK select.....	30
1.3.2 Remote Controller RB-8428.....	12	4.5.2 Register a clip.....	32
Chapter 2 Preparation, connection, and adjustment of this		4.5.3 Play a clip	34
device	13	4.5.4 Edit the IN/OUT point of a clip.....	35
2.1 Preparation of this device (SR-8450)	13	4.5.5 Copy/move clips	35
2.1.1 Connection of video signal input unit and		4.5.6 Delete clips	35
I/F for non-video signal	13	4.5.7 Delete clips/playlists in BANK units.....	36
2.1.2 Video signal output unit	15	4.5.8 Delete clips in Page units	36
2.1.3 Power Connections	16	4.6 Operations about a playlist	37
2.1.4 Starting the device.....	16	4.6.1 Create a new playlist.....	37
2.1.5 Shutting off the device	16	4.6.2 Playing a playlist.....	37
2.2 Preparing the remote controller (RB-8428)	17	4.6.3 Delete a playlist	38
2.2.1 Connecting and Activating the Remote		4.6.4 Add clips to a playlist.....	38
Controller	17	4.6.5 Insert a clip into a playlist	38
2.2.2 Shutting off the remote controller	17	4.6.6 Edit the IN/OUT point of a clip in a playlist	
Chapter 3 Operation in this device	18	39
3.1 HOME Screen.....	18	4.6.7 Edit the playback speed of clips in a	
3.1.1 HOME Screen (SDI IN Status).....	18	playlist.....	39
3.1.2 HOME Screen (POWER Status).....	19	4.6.8 Set the Transition Type of a clips in a	
3.1.3 HOME Screen (Temperature Status 1) 19		playlist.....	40
3.1.4 HOME Screen (Temperature Status 2) 19		4.6.9 Set the Transition Duration for clips in a	
3.1.5 HOME Screen (FAN Status).....	20	playlist.....	41
3.2 MENU Screen	21	4.6.10 Set the Transition Color for clips in a	
3.2.1 Maintenance drawing	21	playlist.....	42
3.3 SSD Information Screen	22	4.6.11 Delete clips in a playlist.....	42
3.4 Thumbnail screen	22	4.7 Operations about the protect function	43

4.7.1 Protecting clips (and playlists).....	44	Chapter 6 Device Specifications	61
4.7.2 Batch protection of clips included in BANK	47	6.1 This device SR-8450	61
4.7.3 Batch protection of clips (and playlists) included in the Page.....	50	6.1.1 Main unit specifications	61
4.7.4 Checking protected clips (and playlists)	53	6.1.2 appearance.....	62
4.8 MENU.....	57	6.2 Remote Controller RB-8428	63
Chapter 5 When you are in trouble	60	6.2.1 Main unit specifications	63
5.1 If it doesn't work properly	60	6.2.2 appearance.....	63
5.2 When an abnormality or malfunction occurs ..	60	Chapter 7 Changelog	64

Chapter 1 About this device

This chapter explains the features of this device, the names of each part, and an overview of their functions.

1.1 summary

This device is a video server that uses SSD as a recording medium and has a simultaneous recording and playback function.

1.2 Features of this device

- **Continuous recording of four 8K60P videos and two 8K60P playback simultaneously**
- **4 input modes: Up to 4 hours of continuous loop recording is possible per input system**
- **2 input modes: Up to 8 hours of continuous loop recording is possible per input system**
- **You can create, edit, and delete clips and playlists with any clip while recording.**
- **Two T-bar remote controls enable independent playback control of two 8K outputs.**
- **Clip transmission with another individual by 10 GbE is possible (future support)**
- **SSD can be replaced (but hot wire insertion and removal are not possible)**
- **Supports up to 32-channel audio (uncompressed, 24-bit) recording**
- **Power Supply (AC)2 reloaded**
- **5U Rackmount Size**

1.3 Names and functions of each part

The names and functional overviews of each part of this device are as follows.

1.3.1 This device SR-8450

● front view

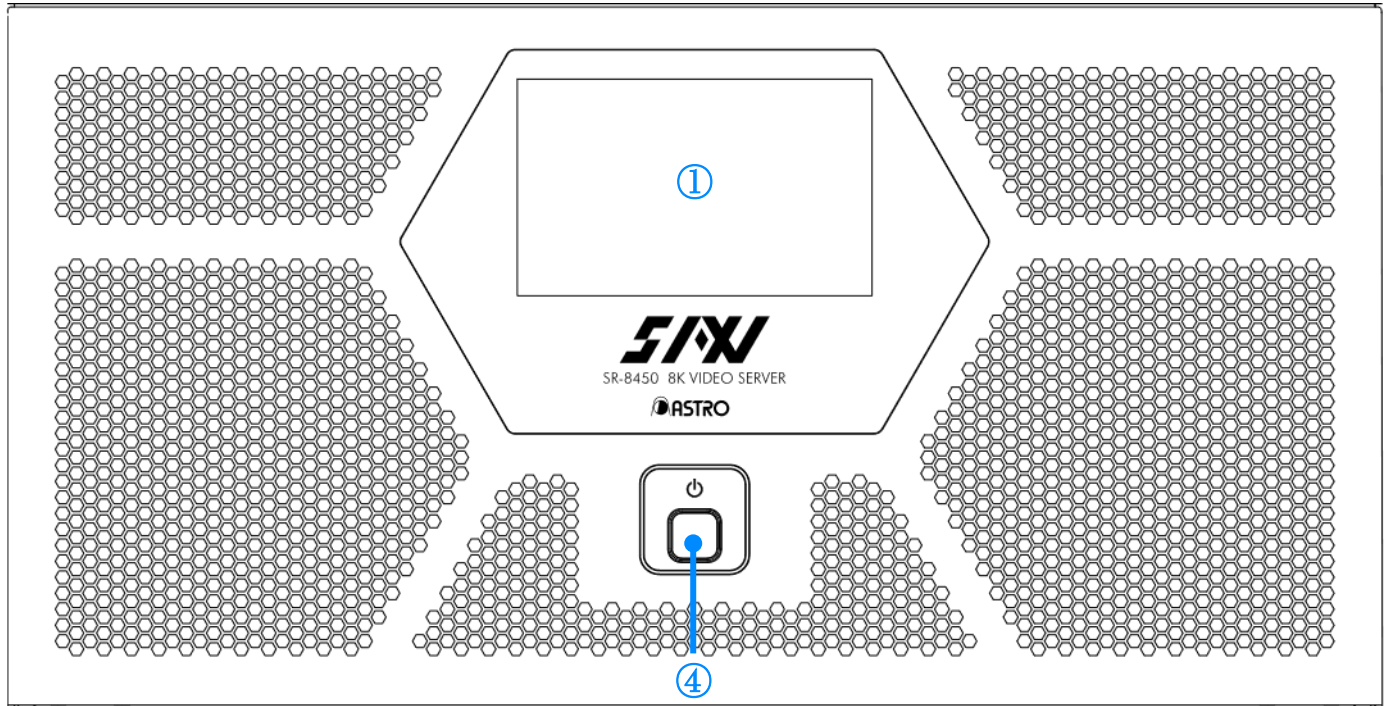

OPEN

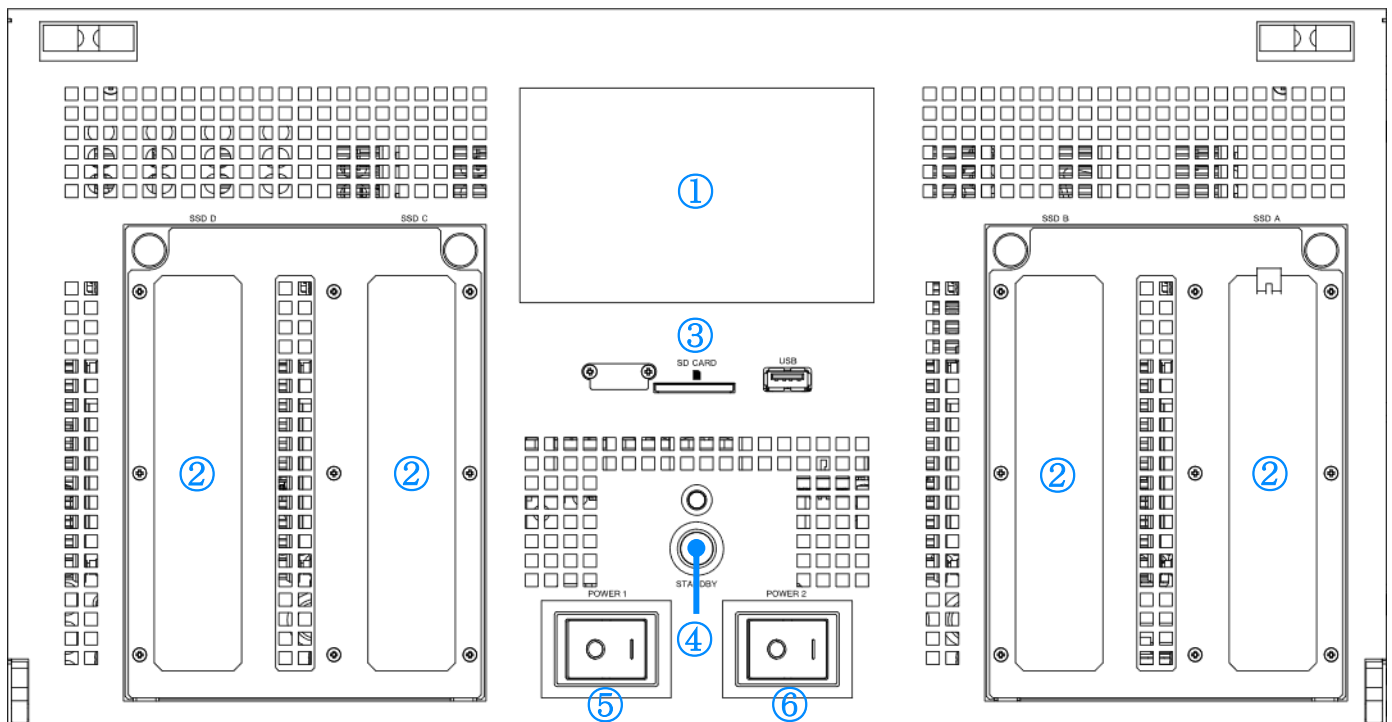

number	name	explanation
①	Touch panel LCD	Displays various statuses.
②	SSD Slots	Reload the SSD.
③	SD card slot	Insert the SD card, upgrade the firmware version, and obtain log information. Used only during maintenance.
④	STANDBY Switch	Start or Shut off this device.
⑤	Main power switch	Turn on the main power supply of this device.
⑥	Redundant power switch	Turn on the redundant power supply of this device.

● Rear View

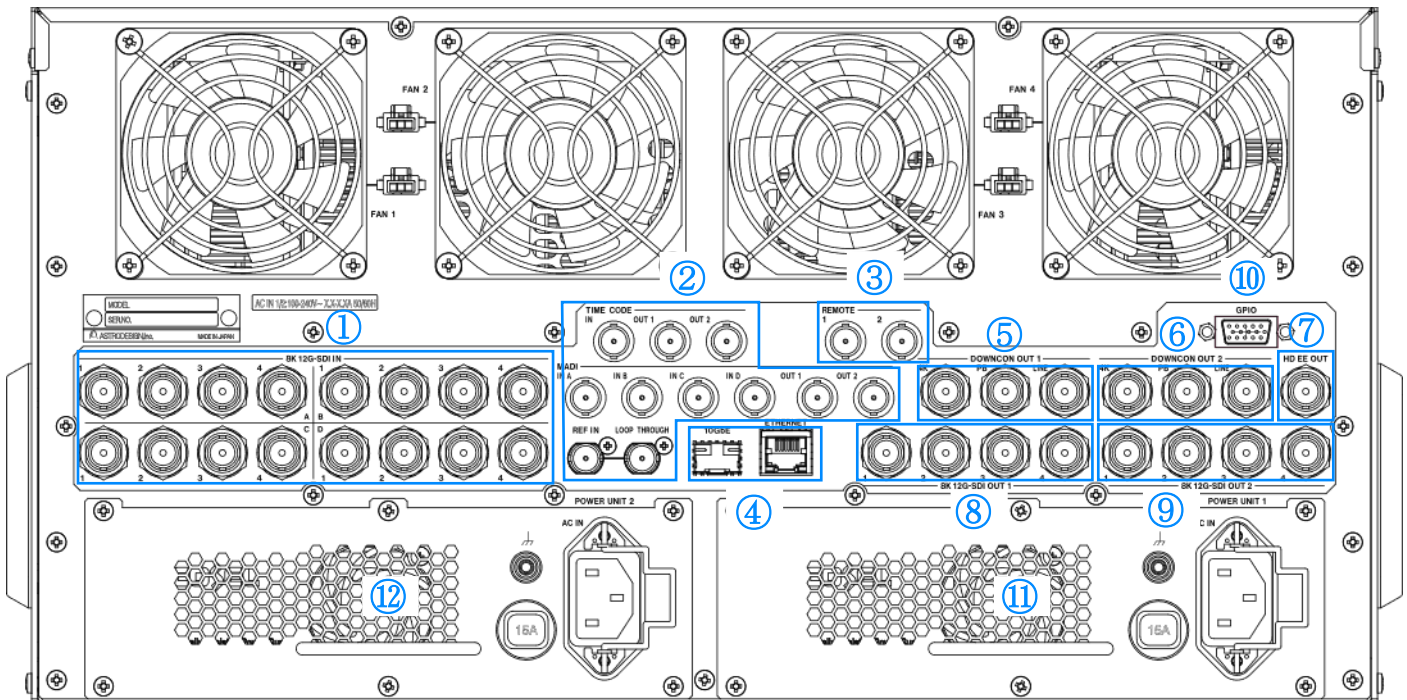

number	name	explanation
①	8K 12G-SDI A 8K 12G-SDI B 8K 12G-SDI C 8K 12G-SDI D	Inputs an 8K video signal.
②	TIMECODE IN	Input an external timecode (LTC) signal.
	TIMECODE OUT1	In LIVE Mode Output the input TC or the internally generated TC.
	TIMECODE OUT2	In PLAY mode Outputs the TC recorded on the SSD.
	MADI A MADI B MADI C MADI D	Input an external MADI signal.
	MADI OUT1	In LIVE Mode Outputs input audio.
	MADI OUT2	In PLAY mode Output the recorded audio to the SSD.
	REF IN	Enter the reference (HD3-value/BB SYNC). * Automatic termination is not supported.
LOOP THROUGH	It will be a passive through of REF IN.	
③	REMOTE	Connect with the remote controller. The left side controls 8K 12G-SDI OUT1 (output system 1) and the right side controls 8K 12G-SDI OUT2 (output system 2). The Baud Rate is 4,000,000 bps.
④	10GbE/Ethernet	1 Communicate with external devices via 10Gbit Ethernet. (Future-proof)
⑤	DOWNCON OUT1	Output the downcon video of output system 1 (4K/HD-PB /HD-LINE, from left to right).
⑥	DOWNCON OUT2	Output the downcon video of output system 2 (4K/HD-PB /HD-LINE, from left to right).
⑦	HD EE OUT	It outputs HD downcon video (EE) of the four input systems.
⑧	8K 12G-SDI OUT1	Outputs an 8K video signal of output system 1.
⑨	8K 12G-SDI OUT2	Outputs an 8K video signal of output system 2.
⑩	GPIO	Used during maintenance.
⑪	Main power supply unit	This is the main power supply of this device. Connect the supplied AC cable.
⑫	Redundant power supply unit	This is a redundant power supply for this device. Connect the supplied AC cable.

1.3.2 Remote Controller RB-8428

● Rear View

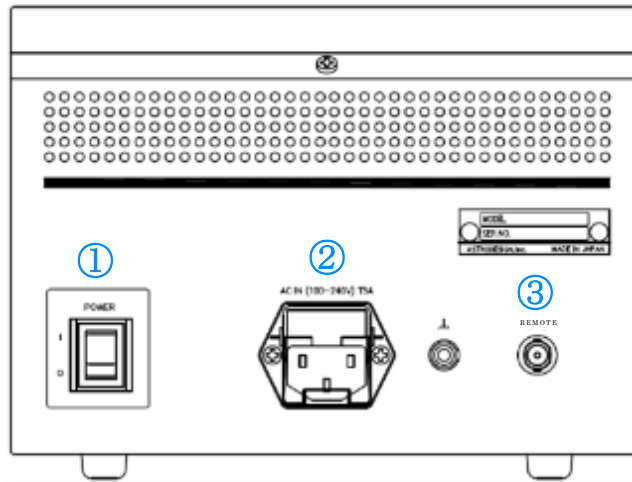

number	name	explanation
①	Remote Controller Power Switch	Start or shut off the remote controller.
②	AC Inlet	Connect the supplied AC cable.
③	REMOTE PIN	Connect the supplied BNC cable for remote controller and communicate with this device.

● front view

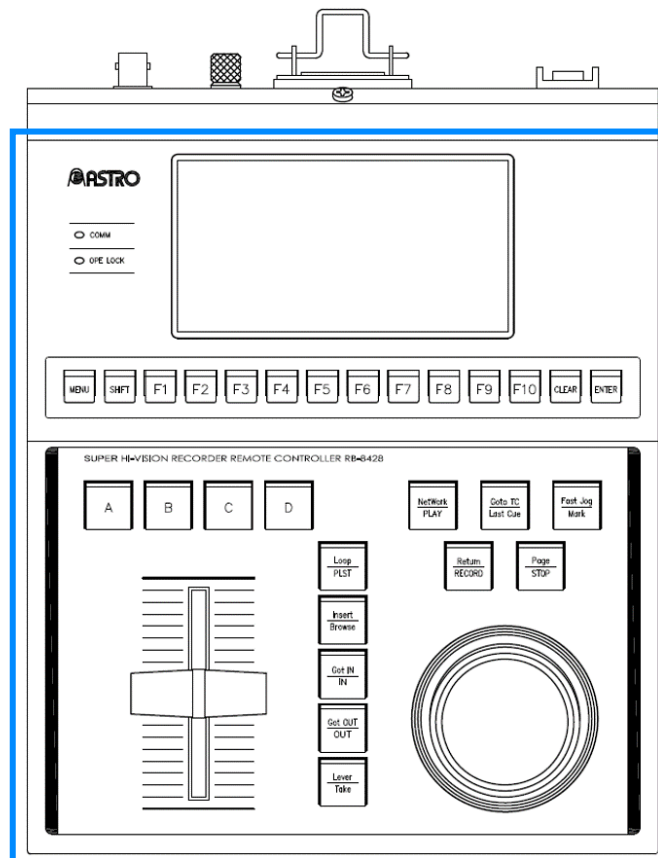

Operation/Display area

For details, see [Chapter 4 Operation from Remote Controller](#).

Chapter 2 Preparation, connection, and adjustment of this device

2.1 Preparation of this device (SR-8450)

This section describes the connection, startup, and shutdown of this device and peripheral devices.

2.1.1 Connection of video signal input unit and I/F for non-video signal

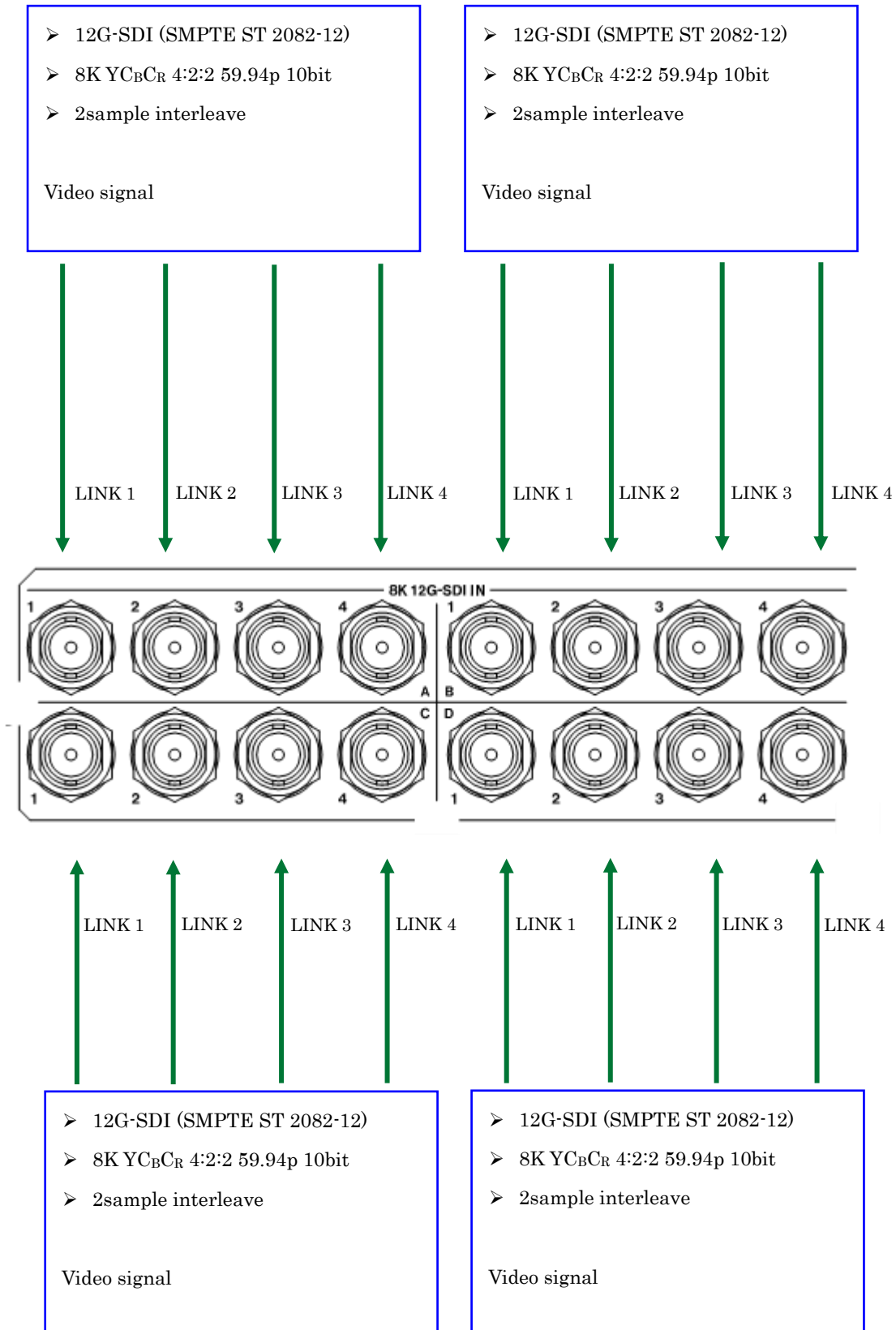

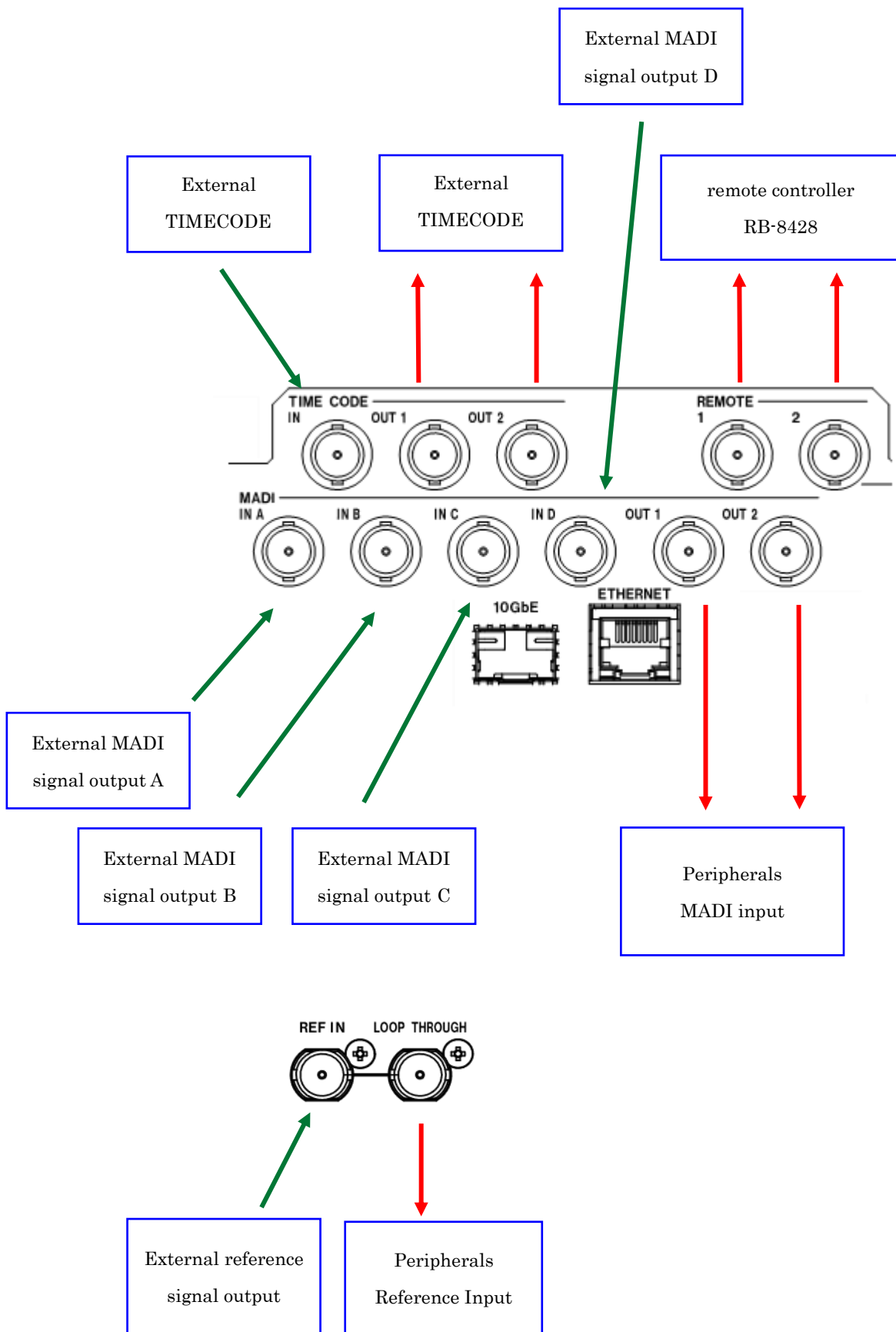

2.1.2 Video signal output unit

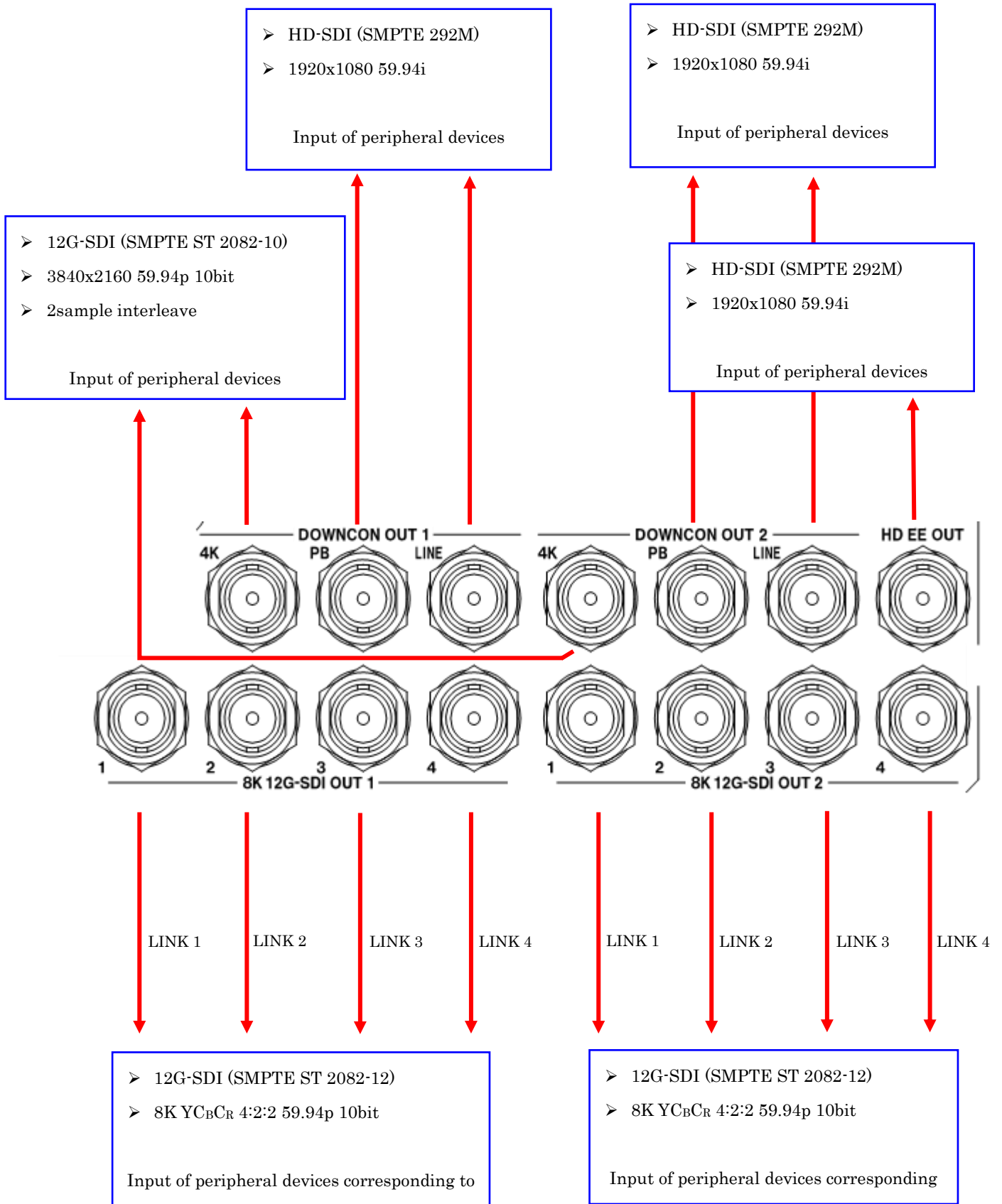

2.1.3 Power Connections

- 1 Ensure that the main power switch and redundancy power switch of this device are turned OFF.
- 2 Connect the supplied AC cable to the main power supply unit of this device and to the AC IN connector of the redundant power supply.

2.1.4 Starting the device

- 1 Make sure that the power supply and all I/O connections are closed.
- 2 Turn on the main power switch and the redundant power switch.
- 3 Turn on the STANDBY switch.
 - The startup screen appears, followed by the HOME screen.

2.1.5 Shutting off the device

- 1 By operation with the remote controller, stop recording and playback completely.
- 2 Press and hold the STANDBY switch for 3 seconds, and then release it when the pop-up "Please Wait..." appears.
- 3 Verify that the touch panel LCD is off and turn off the mains power switch and the redundant power switch.

! Important

- Never turn off the power while recording or playing. This may cause failure of this device or data damage.
- Do not turn off the main power switch and the redundant power switch before discontinuing this device. This may cause a malfunction.
- If the main power switch and the redundant power switch are turned off first from the STANDBY switch, the previous state is not recorded.

2.2 Preparing the remote controller (RB-8428)

This article shows how to connect, start, and shut off the remote controller.

2.2.1 Connecting and Activating the Remote Controller

This article shows how to connect, start, and shut off the remote controller.

- 1 Make sure the remote controller power switch is turned OFF.**
- 2 Connect the BNC cable for the remote controller to the REMOTE terminal.**
- 3 Connect the supplied AC cable to the AC IN connector.**
- 4 Turn on the power switch of remote controller.**

2.2.2 Shutting off the remote controller

- 1 By operation with the remote controller, stop recording and playback completely.**
- 2 Turn off the power switch of remote controller.**

Chapter 3 Operation in this device

3.1 HOME Screen

3.1.1 HOME Screen (SDI IN Status)

When the start of this device is completed, the following HOME screen (SDI IN status) is displayed.

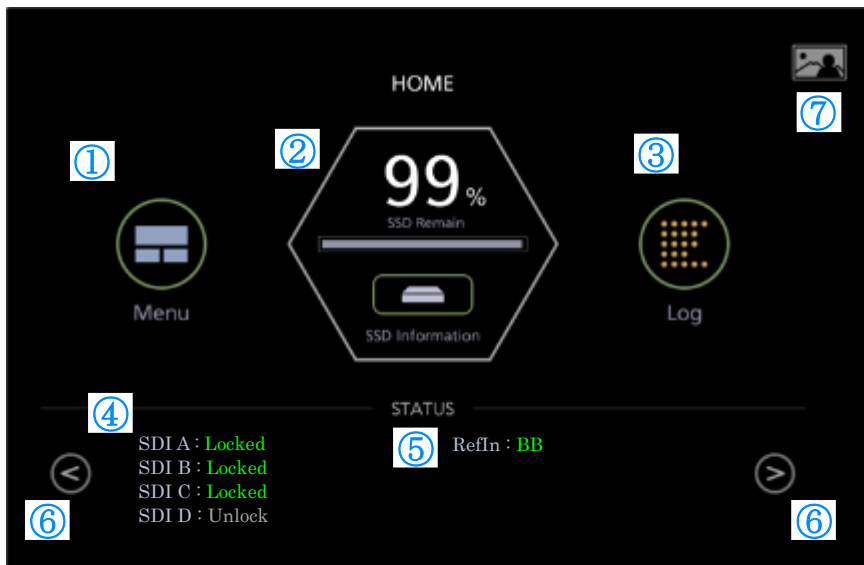

number	name	explanation
①	Menu	Go to MENU screen. (For details, refer to 【3.2 MENU Screen】).
②	SSD Information	SSD Remain: Displays the remaining amount of clip registration area on the SSD. The percentage decreases according to the clip length registered on the SSD. When no clips are registered, 100% is displayed. SSD Information: Displays the SSD Information screen. (For details, refer to 【3.3 SSD Information Screen】.)
③	Log	Displays the logs of this device.
④	12G-SDI INPUT Status	Displays the Lock status of the 12G-SDI input. If it is locked normally, 【Locked】 is displayed, and if it is not Locked, 【Unlock】 is displayed.
⑤	External REF Signal Status	If BlackBurst is input as an external synchronization signal and Lock normally, 【BB】 is displayed when Lock to three-valued synchronization, and 【Unlocked】 is displayed if there is no input.
⑥	Status display toggle switch	Toggles the display of status.
⑦	thumbnail	Set the main device LCD to the thumbnail screen.

● When the HOME screen (SDI IN status) is displayed

- Press the status display toggle switch on the right side to move to 【3.1.2 HOME Screen (POWER Status)】.
- Press the status display toggle switch on the left side to move to 【3.1.4 HOME Screen (FAN Status)】.

3.1.2 HOME Screen (POWER Status)



name	explanation
POWER Status	Displays the status of the supply voltage. If the power supply voltage is normal, OK is displayed, and if it is abnormal, ERROR is displayed. Power1 indicates the status of the mains power supply and Power2 indicates the status of the redundant power supply.

- When the HOME screen (POWER status) is displayed
 - Press the status display toggle switch on the right side to enter **[3.1.3 HOME screen (temperature status 1)]**.
 - Press the status display toggle switch on the left side to move to the **3.1.1 HOME Screen (SDI IN Status)**.

3.1.3 HOME Screen (Temperature Status 1)

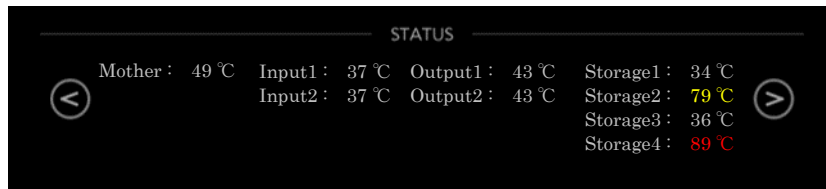

name	explanation
FPGA Temperature Status 1	The temperature status of each FPGA built into this device is displayed. It becomes yellow above 78°C and red above 81°C.

- When the HOME screen (temperature status 1) is displayed
 - Press the status display toggle switch on the right side to go to **[3.1.4 HOME Screen (Temperature Status 2)]**.
 - Press the status display toggle switch on the left side to move to **[3.1.2 HOME Screen (POWER Status)]**.

3.1.4 HOME Screen (Temperature Status 2)

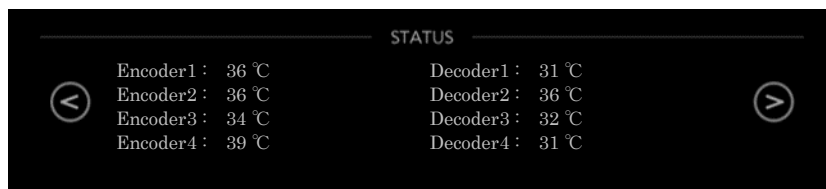

name	explanation
FPGA Temperature Status 2	The temperature status of each FPGA built into this device is displayed. It becomes yellow above 78°C and red above 81°C.

- When the HOME screen (temperature status 2) is displayed
 - Press the status display toggle switch on the right side to move to **[3.1.4 HOME Screen (FAN Status)]**.
 - Press the status display toggle switch on the left side to enter **[3.1.2 HOME Screen (Temperature Status 1)]**.

3.1.5 HOME Screen (FAN Status)

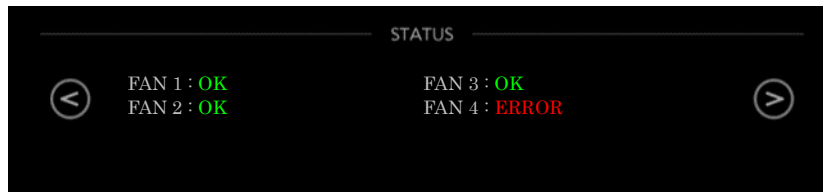

name	explanation
FAN Status	Displays the status of each FAN. If the FAN is rotated normally, 【OK】 is displayed, and if the rotation is abnormal, 【ERROR】 is displayed.

- When the HOME screen (FAN status) is displayed
 - Press the status display toggle switch on the right to move to **【3.1.1 HOME Screen (SDI IN Status)】**.
 - Press the status display toggle switch on the left side to enter **【3.1.3 HOME Screen (Temperature Status 2)】**.

3.2 MENU Screen

Touch the Menu button on the HOME screen to move to the MENU screen as shown below.



number	name	explanation
①	HOME	Go to the HOME screen.
②	Maintenance	Set the RTC and collect logs to the SD card. (For details, see 【3.2. 1 Maintenance Screen】.)
③	Information	Display version information and perform version upgrade.
④	Factory Reset	Restore the settings to the factory default state.

3.2.1 Maintenance drawing

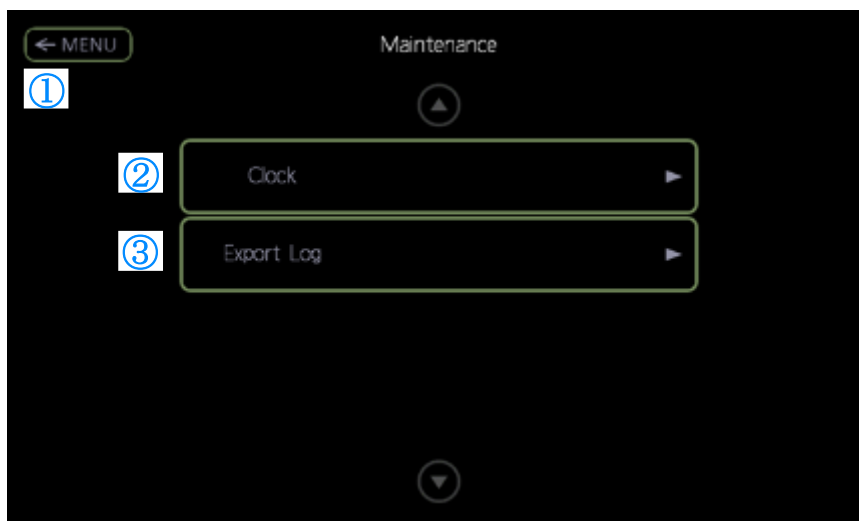

number	name	explanation
①	MENU	Go to the MENU screen.
②	Clock	Set the internal RTC.
③	Export Log	Output the log to the SD card.

3.3 SSD Information Screen

Touch the SSD Information button on the HOME screen to move to the SSD Information screen as shown below.

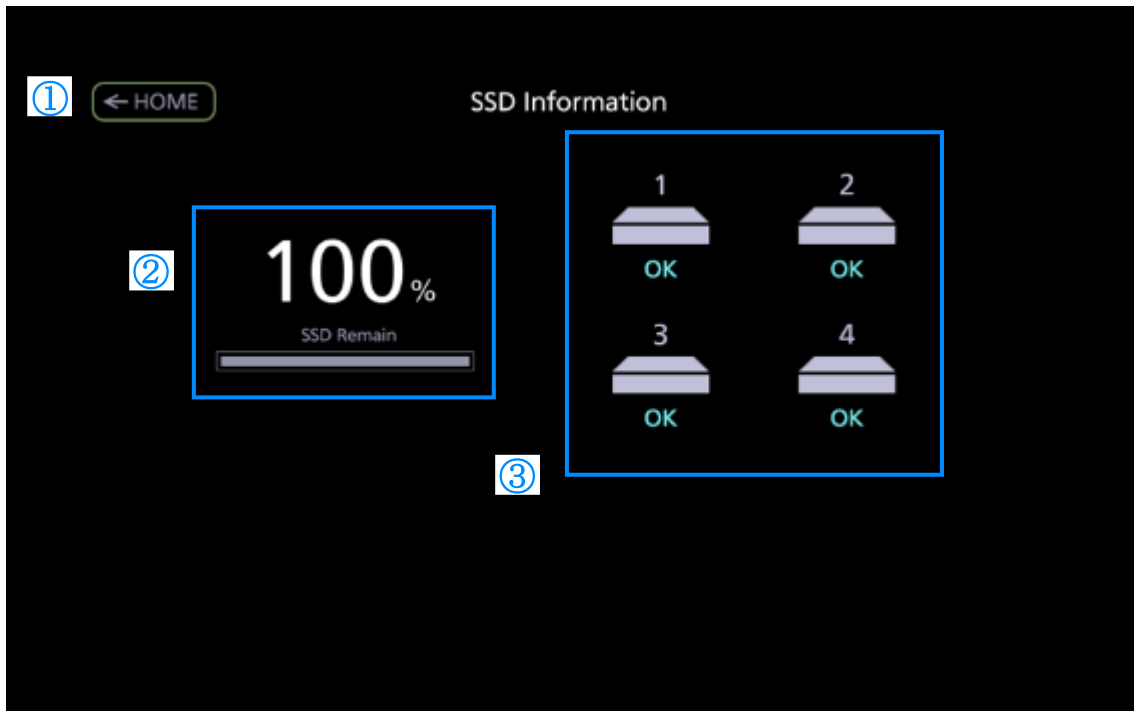

number	name	explanation
①	HOME	Go to the HOME screen.
②	SSD Remain	Displays the remaining amount of clip registration area of the SSD. The percentage decreases according to the clip length registered on the SSD. When no clips are registered, 100% is displayed.
③	SSD status	If SSD is normal, it is displayed as OK, and if there is an abnormality, it is displayed as [ERROR] or [CAUTION] .

3.4 Thumbnail screen

When you touch the thumbnail icon on the HOME screen, this device LCD becomes the thumbnail screen.

On the thumbnail screen, LINE OUT is displayed.

Touch the LCD on the thumbnail screen to return to the HOME screen.

Chapter 4 Operation from the remote controller

The main operation of this device is performed by the remote controller.

4.1 Name and function of each part of the remote controller

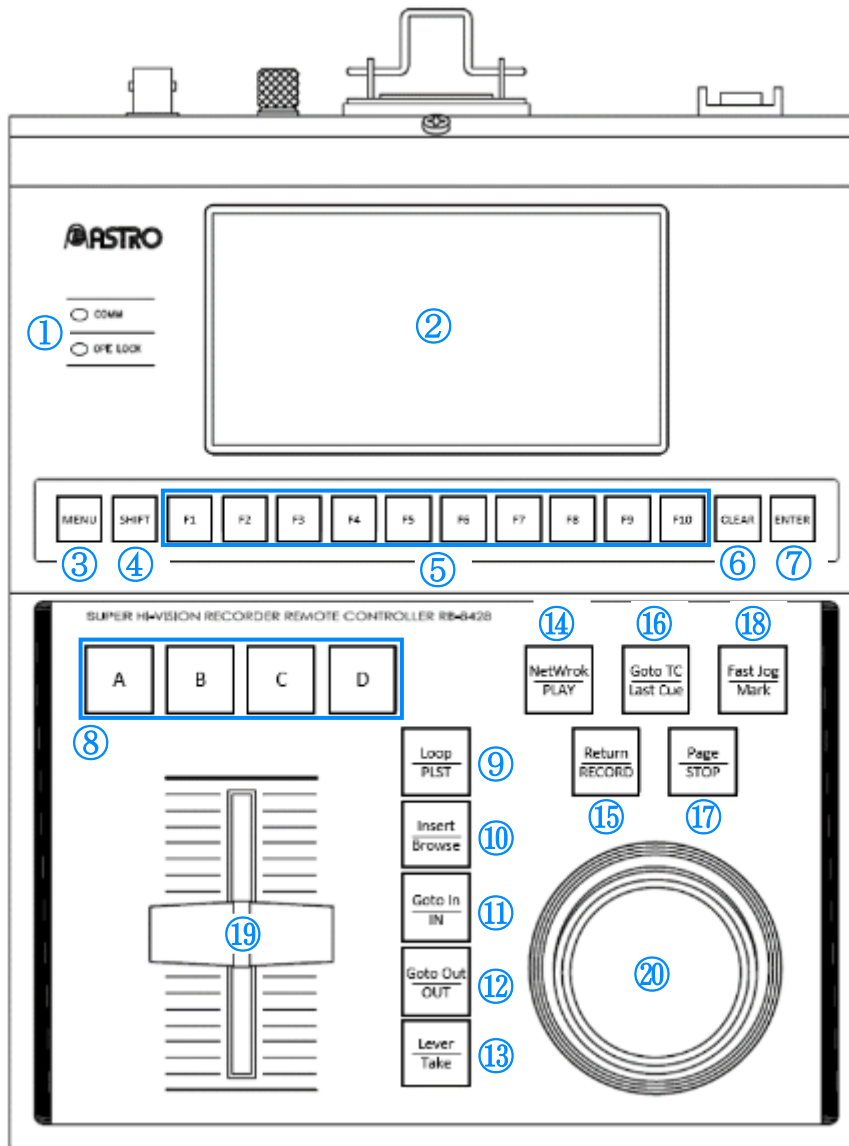

number	name	explanation
①	【COMM LED】 / 【OPELOCK LED】	Notifies you of the establishment of communication with the main unit. /Notifies you of the operation prohibited state.
②	【LCD】	Various displays are performed.
③	【MENU】Button	Transition to the MENU screen.
④	【SHIFT】Button	Switch between Primary MENU and Secondary MENU.
⑤	【FUNCTION】Button	Select clip numbers, etc. and select MENU items.
⑥	【CLEAR】Button	Delete clips, etc. and move the hierarchy of MENU.
⑦	【ENTER】Button	Create clips, etc. and decide on MENU items.
⑧	【A】Button / 【B】Button / 【C】Button / 【D】Button	Switch the output camera input system in Live mode.
⑨	【Loop/PLST】Button	Transition to Playlist editing screen and transition to Loop mode.
⑩	【Insert/Browse】button	Perform transition operations between clips in Playlist and insert clips into playlists.
⑪	【Goto In/IN】Button	Set the IN point of the clip and move the clip to the IN point of the clip.
⑫	【Goto Out/OUT】Button	Set the OUT point of the clip and move the clip to the OUT point.

⑬	【Lever/Take】Button	Insert clips into the playlist. Switch the output camera input system in Live mode.
---	--------------------	--

number	name	explanation
⑭	【NetWork/PLAY】Button	Plays back clips, etc., and references clips recorded on other devices on the 10GbE network (for future support).
⑮	【Return/RECORD】button	Start continuous recording.
⑯	【Goto TC/Last Cue】button	For future support.
⑰	【Page/STOP】Button	Stop playback or switch Page.
⑱	【Fast Jog/Mark】button	Switch the Jog effective speed.
⑲	【T-bar】	Change the playback speed.
⑳	【Jog】	Move within the recorded area and make numerical changes in MENU.

4.2 Operations about simultaneous recording playback

Simultaneous recording and playback consist of the following three modes:

4.2.1 Live mode

- Press the **【Return/RECORD】** button and **LIVE mode** and start continuous loop recording.
 - The **【Return/RECORD】** button lights up red.

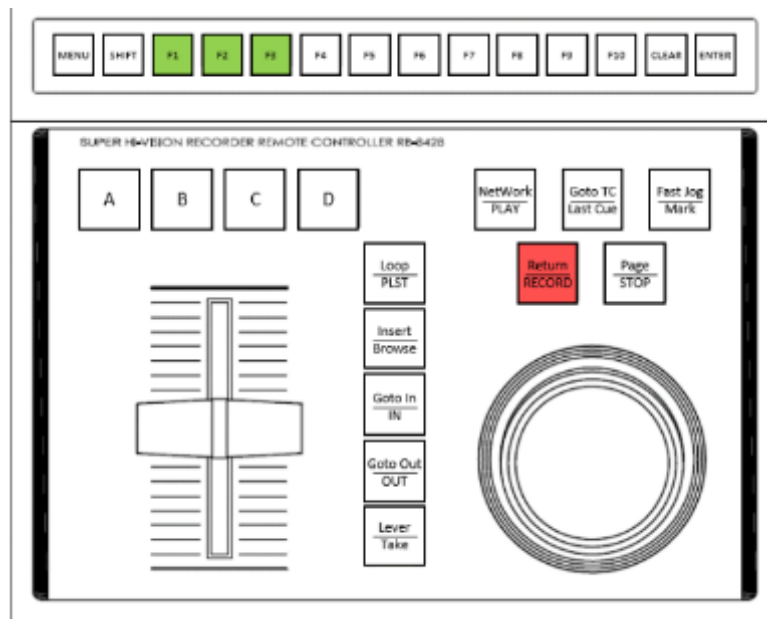

4.2.2 PlayBack mode

- Press the **【NetWork/PLAY】** button, or when you operate **【T-bar】**, it enters **PlayBack mode** and starts chasing playback of the recorded range. For details on the operation of **【T-bar】**, refer to "Variable-speed playback by **【T-bar】**" below.
- At this time, simultaneous recording continues behind the scenes.

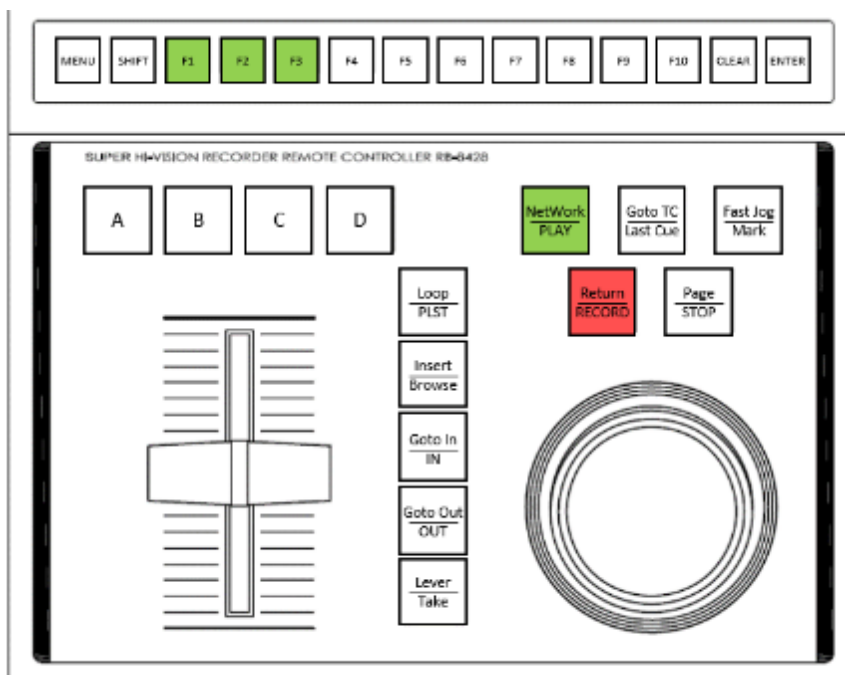

◇ 【T-bar】 About variable-speed playback by

【T-bar】 to change the playback speed during PlayBack mode.

【T-bar】 The relationship between position and playback speed is shown in the figure below.

(1) Constant speed playback

At the top of 【T-bar】 , the video recorded at 60p will be played back at constant speed (60p).

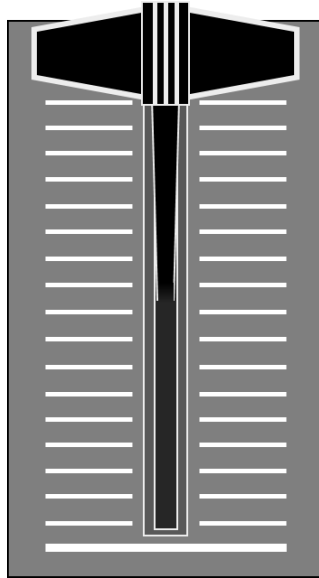

(2) Variable-speed playback

When the 【T-bar】 is lowered, the playback speed decreases as the position of 【T-bar】 goes down.

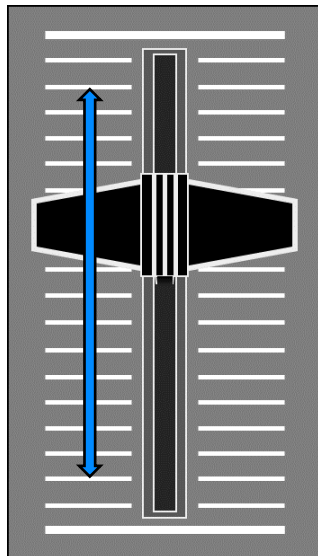

(3) Stop

At the bottom of 【T-bar】 , stop playback, and then put it in Jog mode (Refer to [\[4.2.3\]](#))

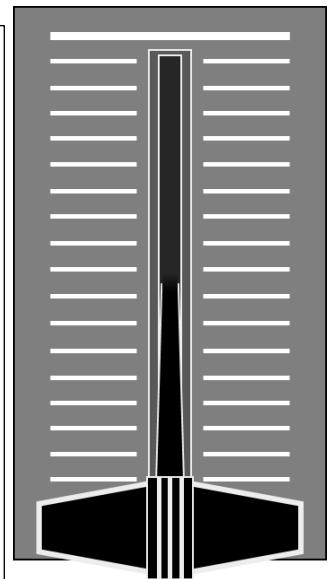

4.2.3 Jog Mode

- When you press the **[Page/STOP]** button or turn **[Jog]** You can enter the Jog mode, display frame still images in the recorded range, and send frames feed or back by turning **[Jog]**.
- At this time, simultaneous recording continues behind the scenes.

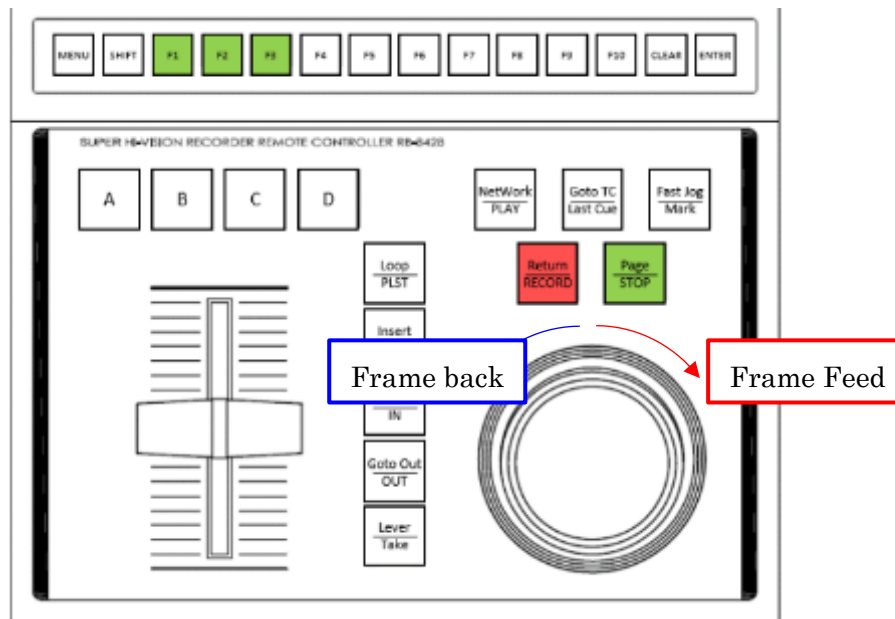

- After pressing the **[SHIFT]** button, press the **[Fast Jog/Mark]** button to increase the number of frame feed steps.
 - The **[Fast Jog/Mark]** button will light up green.

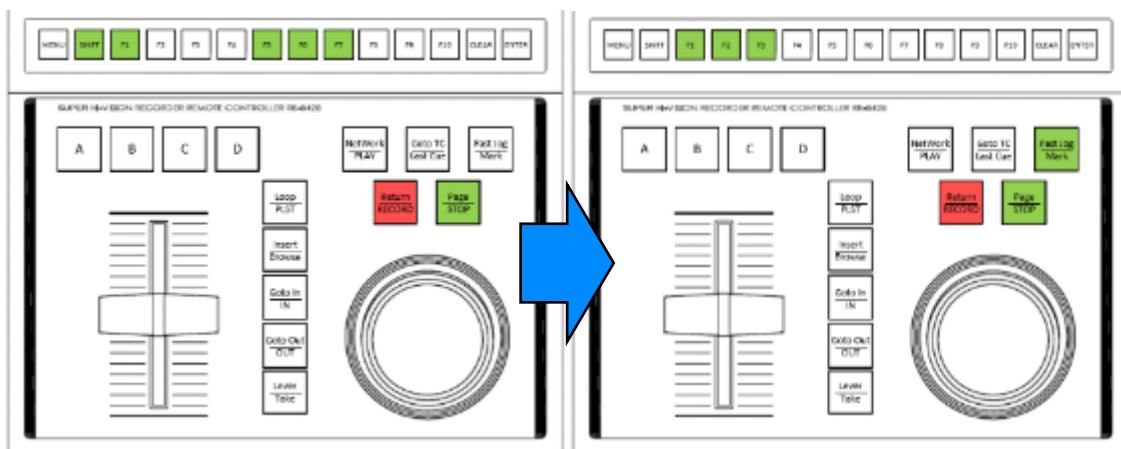

- ✓ Press the **[SHIFT]** button.
- ✓ The **[SHIFT]** button will light up

- ✓ Press the **[Fast Jog/Mark]** button.
- ✓ The **[SHIFT]** button turns off and the **[Fast Jog/Mark]** button lights up green.

4.2.4 Full end of recording

- 1 Press the **[Return/RECORD]** button and the **[Page/STOP]** button at the same time.
- 2 Press the **[ENTER]** button to finish recording completely, or press the **[MENU]** button to continue recording.
 - The **[Return/RECORD]** button turns off and the **[Page/STOP]** button lights up green.

4.3 Working with Mark Points

- During simultaneous recording playback, you can make checkpoint at any timecode as a Mark point and go to see it later.
 - A total of 100 Mark points can be recorded.
- 1 When you press the **[Fast Jog/Mark]** button during LIVE/PlayBack/Jog mode with simultaneous recording and playback, the frame at the time of pressing is remembered as a Mark point.
 - The **[Goto TC/Last Cue]** button will light up green.
 - As an example, if the **[Fast Jog/Mark]** button is pressed while in Live mode, the lighting pattern of each button is as follows.

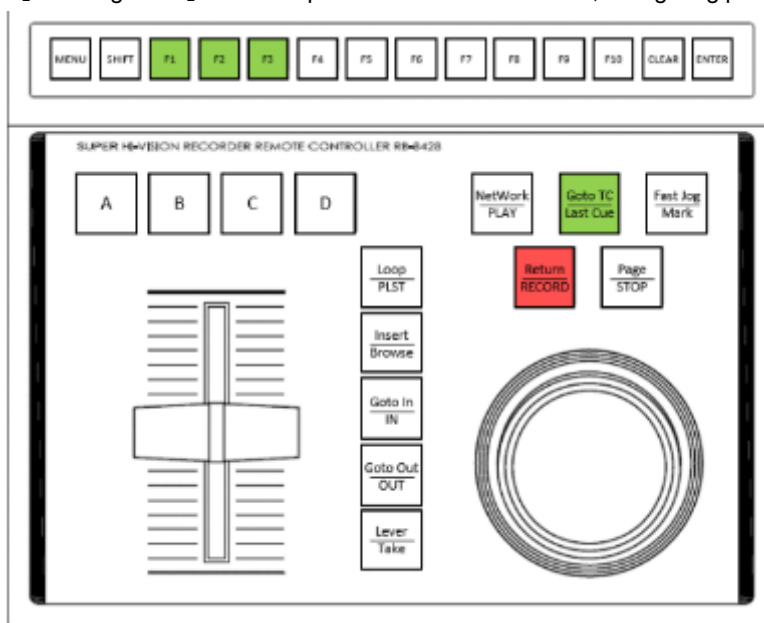

- 2 To refer to the previous Mark point as seen from the most recently referenced Mark point, press the **[Goto TC/Last Cue]** button.

4.4 Operations about Goto TC

- During simultaneous recording playback, it is possible to Cue up to any timecode.
- 1 During LIVE/PlayBack/Jog mode with simultaneous recording and playback, press the **[SHIFT]** button and then press **[Goto TC/Last Cue]**. When you press the button, the following display appears at the bottom of the LCD.

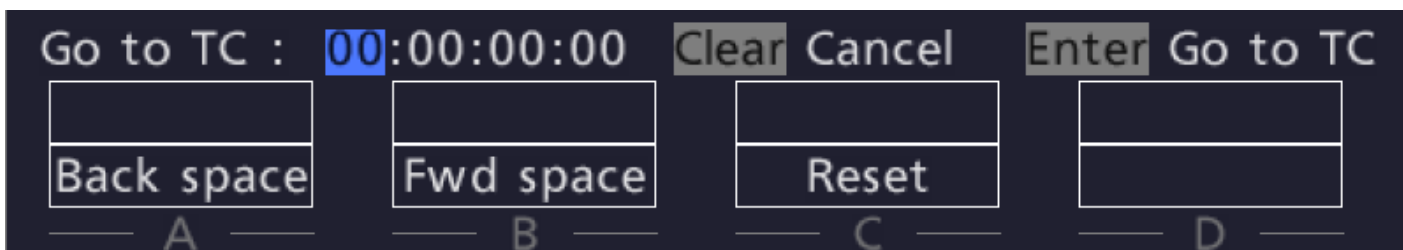

- 2 Press **[F1] ~ [F10]** buttons (each button stands for **[1][2] ... [9]** and **[0]**) to input TC you want to Cue up.
- 3 Each time the **[A]** button is pressed once, the frame and input space are switched → the hour → minutes → seconds, and conversely, the input space is switched from frame → seconds → minutes → hour every time the **[B]** button is pressed once. Press the **[C]** button to reset the entered TC to 00:00:00:00.
- 4 Press the **[ENTER]** button to determine the move TC or press the **[CLEAR]** button if not.

4.5 Clip operations

- With this device, it is possible to register a protected area (clip) that is not overwritten even in continuous loop recording. This article describes the following four operations about clips.
 - Register a clip
 - Play a clip
 - Edit the IN/OUT point of a clip
 - Erase clips
- The clip, along with Page and BANK, is organized as follows, followed by Page, BANK, and Clip in order from the largest parentheses.
- Since **10 Clips** can be registered per BANK, and there are **9 Pages** that can store **9 BANKS**, This device can register up to 810 clips.

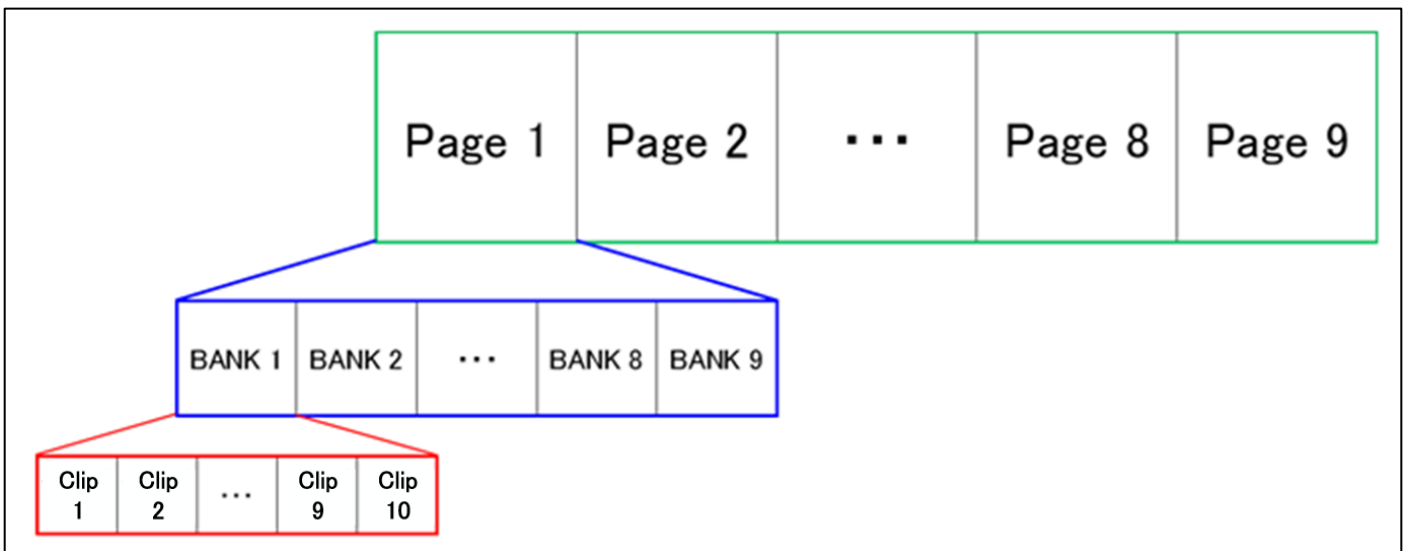

4.5.1 Page-BANK select

First, we will show you the selection operation of Page and BANK. This item [4.5] and the next item [4.6] All of the operations shown in involve selecting this clip. In the following example, suppose that a clip is registered as shown in the following table.

Page	BANK	Clip									
1	1	1	2	3							
	5	1									
	6		2		4		6				
	7					5					
9	1		2	3		5	6		8	9	
	3				4		6		8		
	8							7	8	9	10

- 1 After pressing each button in the order of **[SHIFT]** button → **[Page/STOP]** button, select Page by pressing any one from the **[F1] ~ [F9]** button. The detailed LED lighting pattern is as follows.

✓ Currently, BANK 1 on Page1 is specified, and the **[F1]** **[F2]** **[F3]** buttons light up green.

✓ Press the **[SHIFT]** button.
✓ The **[SHIFT]** button will light up green.

✓ Press the **[Page/STOP]** button.
✓ The button indicating Pages 1 and 9 in which the clip is registered (**[F1]** **[F9]** button) light up green.

✓ Press **[F9]** to specify Page9.
✓ Buttons indicating clips 2, 3, 5, 6, 8, and 9 registered in BANK 1 on Page 9 (**[F2]** **[F3]** **[F5]** **[F6]** **[F8]** **[F9]** button) light up green.

- 2 After pressing the **【SHIFT】** button, select **BANK** by pressing any one from the **【F1】 ~ 【F9】** button. The detailed LED lighting pattern is as follows.

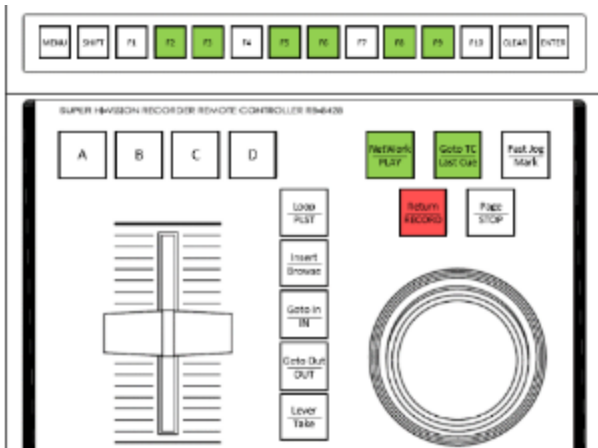

- ✓ Currently, BANK1 of Page9 is designated, and **【F2】【F3】【F5】【F6】【F8】【F9】** buttons light up green.

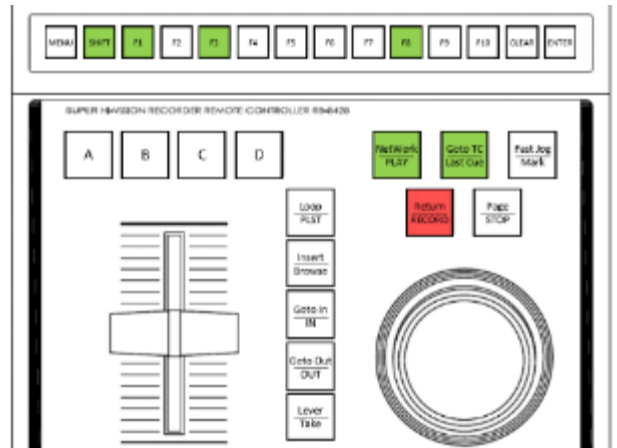

- ✓ Press the **【SHIFT】** button.
- ✓ The buttons indicating BANK 1, 3, and 8 in which the clip is registered (**【F1】 【F3】 【F8】** button) light up green.

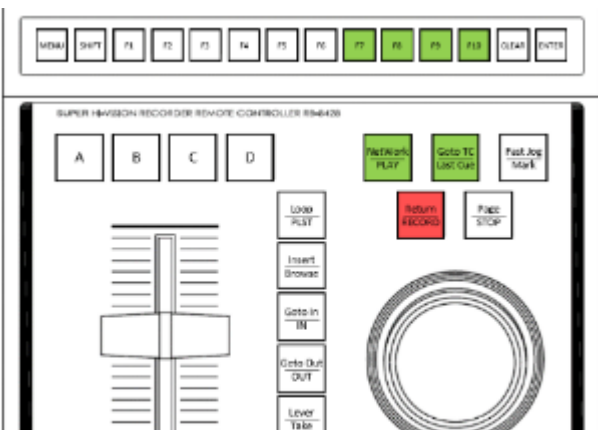

- ✓ Press **【F8】** , Specify **BANK8**.
- ✓ The buttons indicating clips 7, 8, 9, and 10 registered in **BANK8** on Page 9 (**【F7】 【F8】 【F9】 【F10】** button) light up green.

4.5.2 Register a clip

- To register a clip, follow these steps:

- Here, as an example, Suppose the clip is registered with the same Page, BANK, and clip numbers as in the example shown in [4.5.1](#). Suppose you register clip 6 in BANK8 of Page 9.

1 Follow the instructions in [4.5.1](#) , and specify Page, BANK.

2 Press the **【Goto In/IN】** button at any frame to set the IN point of the clip.

- The **【Goto In/IN button】** lights up green.

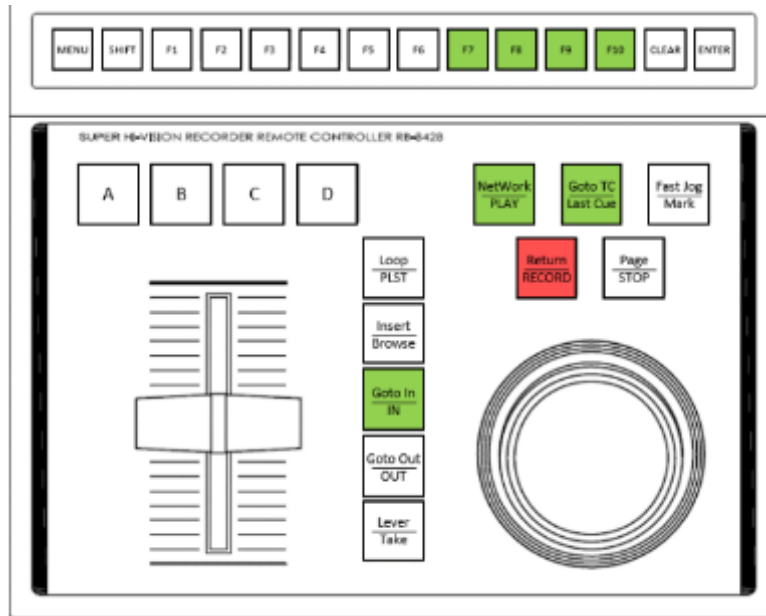

3 Press the **【Goto Out/OUT】** button at any frame to set the OUT point of the clip.

- The **【Goto Out/OUT】** button will light up green.

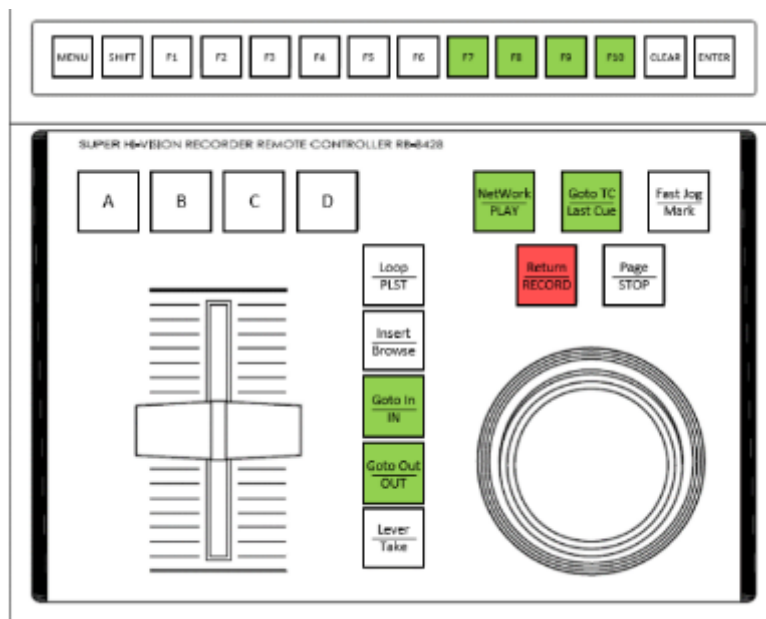

4 Press the button that does not light up green on the **【F1】 ~ 【F10】** button to register the clip to the corresponding clip number.

- As an example, if you newly register clip 6 here, the **【F6】** button will light up green.

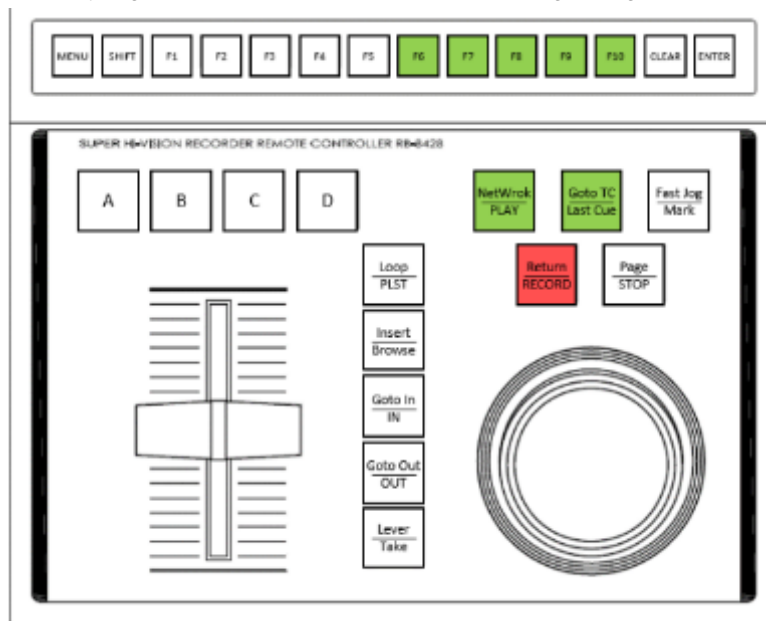

4.5.3 Play a clip

- To play a clip, follow these steps:

- Here, as an example, Suppose that the clip is registered with the same Page, BANK, and clip numbers as in the example shown in [4.5.1](#) , and you want to play clip 7 registered in BANK8 on Page 9.

- 1 Follow the instructions in [4.5.1](#) , and specify Page, BANK.

- 2 Among the **【F1】 ~ 【F10】** buttons, the button that has already registered the clip lights up green, so press the button corresponding to the clip number you want to play from among these.

- Among the **【F1】 ~ 【F10】** buttons, the button corresponding to the selected clip number lights up red.
- As an example, clip 7 is played here, the **【F7】** button will light up red.

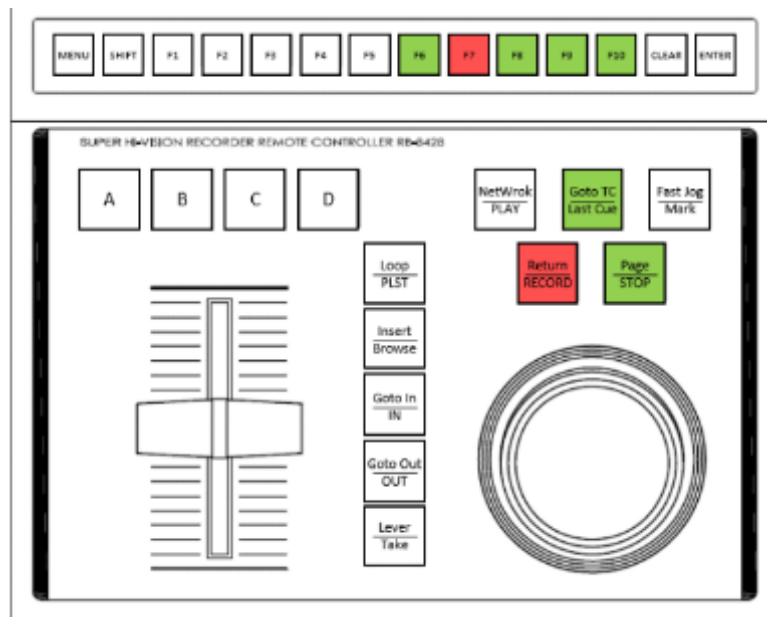

- 3 The selected clip is played by pressing the **【NetWork/PLAY】** button or moving **【T-Bar】**.

- The **【NetWork/PLAY】** button will light up green.

- 4 To stop playback, press the **【Page/STOP】** button.

- The **【Page/STOP】** button lights up green.

- 5 After pressing the **【SHIFT】** button, press the **【Goto In/IN】** button to the first frame of the selected clip, and press the **【Goto Out/OUT】** button, Moves to the last frame of the selected clip.

- Also, the **【Jog】** operation moves to any frame in the clip.

MEMO

- After the clip is played and the OUT point is exceeded, post-roll playback is performed within the set time. (For details, refer to About guard bands in [4.8 MENU](#)).
- Loop playback is enabled by pressing the buttons **【SHIFT】** → **【Loop/PLST】** to enable Loop playback and play the selected clip in Loop.

4.5.4 Edit the IN/OUT point of a clip

- When editing a clip, you can change the IN and OUT points of clips that are already registered.
 - To edit a clip, follow these steps:
- 1 [\[4.5.1\]](#) Follow the instructions in, and specify Page, BANK.
 - 2 Among the **【F1】 ~ 【F10】** buttons, the button that has already registered the clip lights up green, so press the button corresponding to the clip number you want to edit the IN / OUT point from among these.
 - Among the **【F1】 ~ 【F10】** buttons, the button corresponding to the selected clip number lights up red.
 - 3 After operating **【Jog】** and moving to any frame, set a new IN point by pressing the **【Goto In/IN】** button, and press the **【Goto Out/OUT】** button to set a new IN point. Set the OUT point.



- The range within which you can edit the IN point and OUT point is within the area of the guard band.
- Even if the guard band area is set to a new IN point or OUT point, the guard band area is the area at the time of clip registration.

4.5.5 Copy/move clips

- To copy and move clips, follow these steps:
- Here, as an example, Suppose that a clip is registered on the same Page as in the example shown in [\[4.5.1\]](#), the same clip number in BANK, and you want to erase clip 9 registered in BANK8 on Page 9.
- 1 Follow the instructions in [\[4.5.1\]](#), and specify Page, BANK.
 - 2 Among the **【F1】 ~ 【F10】** buttons, the button that has already registered the clip lights up green, so press the button corresponding to the clip number you want to copy or move from among these.
 - Among the **【F1】 ~ 【F10】** buttons, the button corresponding to the selected clip number lights up red.
 - 3 Specify the copy destination or the clip number of the destination from the **【F1】 ~ 【F10】** button of any Page or BANK. At this time, the clip number that can be selected as the copy destination or move destination is only the button that is off (clip has not yet been registered).
 - 4 Press the **【A】** button to make a copy or press the **【B】** button to move.

4.5.6 Delete clips

- To delete a clip, follow these steps:
- Here, as an example, Suppose that a clip is registered on the same Page as in the example shown in [\[4.5.1\]](#), the same clip number in BANK, and you want to erase clip 9 registered in BANK8 on Page 9.
- 1 Follow the instructions in [\[4.5.1\]](#), and specify Page, BANK.
 - 2 Press the **【CLEAR】** button.
 - **【CLEAR】**The button lights up red.
 - 3 Among the **【F1】 ~ 【F10】** buttons, the button that has already been registered for the clip lights up, so if you press the button corresponding to the clip number you want to delete from among these, a confirmation message will be displayed.
 - 4 When you press the **【ENTER】** button, the corresponding clip is deleted. **【CLEAR】** button to cancel it.
 - Among the **【F1】 ~ 【F10】** buttons, the button corresponding to the selected clip number is off.



- Clips that were selected before pressing the **【CLEAR】** button in the above operation will not be deleted.

4.5.7 Delete clips/playlists in BANK units

- To delete clips and playlists in BANK units, follow these steps:
 - 1 Follow the instructions in [\[4.5.1\]](#) to specify Page.
 - 2 Press the **【SHIFT】** button to enter the BANK selection state. And press the **【CLEAR】** button.
 - **【CLEAR】**The button lights up red.
 - 3 Among the **【F1】 ~ 【F10】** buttons, the BANK button that has already been registered as a clip/playlist lights up, so when you press the button corresponding to the BANK number you want to delete from among these, a confirmation message is displayed.
 - 4 When you press the **【ENTER】** button, the corresponding BANK is deleted. **【CLEAR】** button to cancel it.
 - Among the **【F1】 ~ 【F10】** buttons, the button corresponding to the selected BANK number is turned off.

4.5.8 Delete clips in Page units

- To delete clips per Page, follow these steps:
 - 1 After pressing the **【SHIFT】** button, press **【Page/STOP】** to enter the Page selection screen.
 - 2 Press the **【CLEAR】** button.
 - **【CLEAR】**The button lights up red.
 - 3 Among the **【F1】 ~ 【F10】** buttons, the button of the Page where the clip is already registered lights up, so when you press the button corresponding to the Page number you want to delete from among these, a confirmation message is displayed.
 - 4 When you press the **【ENTER】** button, the corresponding Page clips are deleted. **【CLEAR】** button to cancel it.



- Erasing clips per Page does not delete playlists.

4.6 Operations about a playlist

- With this device, it is possible to create playlists that combine any clip. This article describes the following seven operations about playlists.
- Playlists are stored in BANK10, which is a "playlist-only bank" built into each Page.
- Since each **BANK10** having **9 Pages** built in this device can create **10 playlists** each, You can create up to 90 playlists with this device.
- You can add up to 100 clips to a playlist.

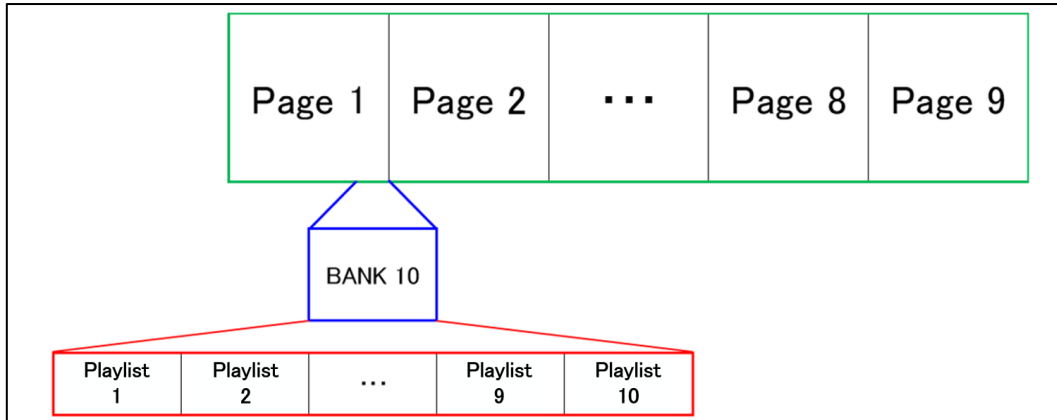

4.6.1 Create a new playlist

- To create a playlist, follow these steps:
 - 1 Follow the instructions in [\[4.5.1\]](#) to specify Page, followed by BANK10.
 - 2 If you press the button that does not light up green among the **[F1] ~ [F10]** buttons, a confirmation message will be displayed.
 - 3 Press **[ENTER]** to create an empty playlist with the corresponding playlist number. **[CLEAR]** to cancel it.

4.6.2 Playing a playlist

- To play a playlist, follow these steps:
 - 1 Follow the instructions in [\[4.5.1\]](#) to specify Page, followed by BANK10.
 - 2 Among the **[F1] ~ [F10]** buttons, the button that has already created a playlist lights up green, so press the button corresponding to the playlist you want to play from among these buttons and select the playlist.
 - 3 Press the **[NetWork/PLAY]** button or move **[T-Bar]** to play the selected playlist.
 - The **[NetWork/PLAY]** button will light up green.
 - 4 To stop playback, press the **[Page/STOP]** button.
 - The **[Page/STOP]** button lights up green.
 - 5 After pressing the **[SHIFT]** button, press the **[Goto In/IN]** button to go to the first frame of the very first clip in the selected playlist, and press the **[Goto Out/OUT]** button, Moves to the last frame of the very last clip.
 - Also, the **[Jog]** operation moves to any frame in the clip.



- After the OUT point is exceeded after the playlist is played, post-roll playback is performed within the set time. (For details, refer to About guard bands in [\[4.8 MENU\]](#)).
- By pressing the buttons **[SHIFT]** → **[Loop/PLST]**, Loop playback is enabled, and the selected playlist is played back by Loop.

4.6.3 Delete a playlist

- To delete a playlist, follow these steps:

- 1 Follow the instructions in [\[4.5.1\]](#) to specify Page, followed by BANK10.
- 2 Press the **[CLEAR]** button.
 - **[CLEAR]**The button lights up red.
- 3 Among the **[F1]** ~ **[F10]** buttons, the button that has already registered the playlist lights up green, so when you press the button corresponding to the playlist you want to delete from among these, a confirmation message is displayed.
- 4 Press **[ENTER]** to delete the corresponding playlist. **[CLEAR]** to cancel it.
 - Among the **[F1]** ~ **[F10]** buttons, the button corresponding to the selected playlist number is off.



- Playlists that were selected before pressing the **[CLEAR]** button in the above [operation 3](#) will not be deleted when the **[CLEAR]** button is pressed.

4.6.4 Add clips to a playlist

- To add a sequential clip to the end of a playlist, follow these steps:

- 1 Follow the instructions in [\[4.5.1\]](#) to specify Page, followed by BANK10.
- 2 Among the **[F1]** ~ **[F10]** buttons, the button that has already created a playlist lights up green, so press the button corresponding to the playlist to which you want to add a clip from among these, and select the playlist.
- 3 Press the **[SHIFT]** button and specify the BANK where the clips you want to add to the currently selected playlist are stored.
- 4 If you press the **[ENTER]** button after pressing the button corresponding to the clip number you want to add to the currently selected playlist among the **[F1]** ~ **[F10]** buttons, the corresponding clip will be added to the end of the currently selected playlist.
- 5 You can continue to add clips by operation 3→4 until you press the **[Return/RECORD]** button to transition to LIVE mode.

4.6.5 Insert a clip into a playlist

- To insert a clip other than the end of a playlist, follow these steps:

- 1 Follow the instructions in [\[4.5.1\]](#) to specify Page, followed by BANK10.
- 2 Among the **[F1]** ~ **[F10]** buttons, the button that has already created a playlist lights up green, so press the button corresponding to the playlist you want to insert a clip from among these, and select the playlist.
- 3 Press the **[Loop/PLST]** button to display the list of clips stored in the playlist.
- 4 After pressing the **[Insert / Browse]** button, operate **[Jog]** to move the cursor to the position where you want to insert the clip.
- 5 Specify BANK by pressing the **[SHIFT]** button and pressing anything from the **[F1]** ~ **[F9]** button.
- 6 Among the **[F1]** ~ **[F10]** buttons, press the button corresponding to the clip number you want to insert into the currently selected playlist, and select the clip to be inserted.
- 7 Press the **[A]** button, **[Lever/Take]** button, or **[SHIFT]** button, and then press the **[Insert/Browse]** button to insert the clip into the playlist.

4.6.6 Edit the IN/OUT point of a clip in a playlist









- To edit the IN/OUT points of clips stored in a playlist, follow these steps:
- 1 Follow the instructions in [\[4.5.1\]](#) to specify Page, followed by BANK10.
 - 2 Among the **[F1] ~ [F10]** buttons, the button that has already created a playlist lights up green, so press the button corresponding to the playlist containing the clip you want to edit the IN / OUT point from among these, and select the playlist.
 - 3 Press the **[Loop/PLST]** button to display the list of clips stored in the playlist.
 - 4 After pressing the **[Insert/Browse]** button, operate **[Jog]** to move the cursor to the clip you want to edit the IN / OUT point.
 - 5 Press the **[Goto In/IN]** button to set a new IN point, and press the **[Goto Out/OUT]** button to set a new IN point. Set the OUT point.

4.6.7 Edit the playback speed of clips in a playlist

- To edit the playback speed of a clip stored in a playlist, follow these steps:
- 6 Follow the instructions in [\[4.5.1\]](#) to specify Page, followed by BANK10.
 - 7 Among the **[F1] ~ [F10]** buttons, the button that has already created a playlist lights up green, so press the button corresponding to the playlist containing the clip you want to edit the playback speed from among these, and select the playlist.
 - 8 Press the **[Loop/PLST]** button to display the list of clips stored in the playlist.
 - 9 After pressing the **[Insert / Browse]** button, operate **[Jog]** and move the cursor to the clip you want to edit the playback speed.
 - 10 After pressing the **[B]** button, adjust the playback speed by operating **[T-Bar]**.
 - 11 Press the **[ENTER]** button to re-register the clip.

4.6.8 Set the Transition Type of a clips in a playlist

- When playing a playlist, the following five effects are available as video transitions at the end of the clip.

symbol	name	Current clip	Next clip (Parameter setting side)	effect
C	Cut			Plays the next clip without effects.
M	Mix			Gradually swaps from the current clip to the next. * Since the next clip starts playing in advance, the playback time is shortened by the set time. * The playback speed during the Mix effect will be the current clip.
>	Fade To Color			The video in the current clip gradually becomes the specified solid color. The next clip plays normally.
<	Fade From Color			The current clip ends normal playback, and the next clip gradually enters normal playback from the specified solid color.
In	Fade To/From Color			Do Fade To Color and Fade From Color.

Specified solid color 

- To set the Transition Type of a clip stored in a playlist, follow these steps:

- Follow the instructions in [4.5.1](#) to specify Page, followed by BANK10.
- Among the **[F1]** ~ **[F10]** buttons, the button that has already created a playlist lights up green, so press the button corresponding to the playlist containing the clip you want to edit the IN / OUT point from among these, and select the playlist.
- Press the **[Loop/PLST]** button to display the list of clips stored in the playlist.
- After pressing the **[Insert / Browse]** button, operate **[Jog]** to move the cursor to the clip you want to edit the Transition Type.
- After pressing the **[SHIFT]** button, press the **[C]** button to display the Transition Type setting screen.
- Press the **[F1]** ~ **[F5]** button to set the Transition Type.

4.6.9 Set the Transition Duration for clips in a playlist

- To set the Transition Duration of a clip stored in a playlist, follow these steps:
- 1 Follow the instructions in [\[4.5.1\]](#) to specify Page, followed by BANK10.
 - 2 Among the **【F1】 ~ 【F10】** buttons, the button that has already created a playlist lights up green, so press the button corresponding to the playlist containing the clip you want to edit the playback speed from among these, and select the playlist.
 - 3 Press the **【Loop/PLST】** button to display the list of clips stored in the playlist.
 - 4 After pressing the **【Insert / Browse】** button, operate **【Jog】** and move the cursor to the clip you want to edit the playback speed.
 - 5 After pressing the **【C】** button, adjust the playback speed by operating **【Jog】**.
 - 6 Press the **【ENTER】** button to complete the setting. Press the **【CLEAR】** button to cancel it.



- The maximum setting time is 20 seconds.
- It does not apply if the Transition Type is Cut.
- If the setting value of Transition Duration is an error, it is displayed in red after setting is completed. For details, see the note "About Transition Duration Error" below.

✧ About Transition Duration Error

Transition Duration will be an error if it is set to the following setting. If you play with the error, playlist is played with the Transition Type is Cut.

- When the setting time of the Mix is longer than the playback time of the clip being set or the previous clip
- If the Fade To Color setting time is longer than the playback time of the previous clip
- If the Fade From Color setting time is longer than the duration of the clip you are setting
- Fade To/From Color is half the duration of the setting clip or the previous clip
- Mix, Fade To Color, Fade From Color, or Fade To/From Color are overlapped each other

4.6.10 Set the Transition Color for clips in a playlist

- To set the Transition Color of a clip stored in a playlist, follow these steps:
- 1 Follow the instructions in [\[4.5.1\]](#) to specify Page, followed by BANK10.
 - 2 Among the **[F1]** ~ **[F10]** buttons, the button that has already created a playlist lights up green, so press the button corresponding to the playlist containing the clip you want to edit the playback speed from among these, and select the playlist.
 - 3 Press the **[Loop/PLST]** button to display the list of clips stored in the playlist.
 - 4 After pressing the **[Insert / Browse]** button, operate **[Jog]** and move the cursor to the clip you want to edit the playback speed.
 - 5 After pressing the **[SHIFT]** button, press the **[B]** button to display the setting screen.
 - 6 Press the **[F1]** ~ **[F3]** button and select R, G, B and adjust the Transition Color by operating **[Jog]**.
 - 7 Press the **[ENTER]** button to complete the setting. Press the **[CLEAR]** button to cancel it.



- Each color can be set in the range of 0~255.
- A color swatch appears in the settings.
- It does not apply when the Transition type is Cut or Mix.

4.6.11 Delete clips in a playlist

- To delete a clip stored in a playlist, follow these steps:
- 1 Follow the instructions in [\[4.5.1\]](#) to specify Page, followed by BANK10.
 - 2 Among the **[F1]** ~ **[F10]** buttons, the button that has already created a playlist lights up green, so press the button corresponding to the playlist containing the clip you want to delete from this playlist and select the playlist.
 - 3 Press the **[Loop/PLST]** button to display the list of clips stored in the playlist.
 - 4 After pressing the **[Insert / Browse]** button, operate **[Jog]** and move the cursor to the clip you want to delete from the playlist.
 - 5 When you press the **[D]** button, a confirmation message is displayed.
 - 6 Press **[ENTER]** to delete the selected clip. **[CLEAR]** to cancel it.

4.7 Operations about the protect function

- With this device, it is possible to protect (prohibit deletion) Page, BANK and clips. This article describes the operations about protection.
- Clip playlists registered after batch protection of Page and BANK are not protected. Again, a protect operation is required.
- Protected clip playlists are not deleted by **[clear]**.
- If a protected clip playlist is eligible for deletion, display the following pop-up on the LCD for 3 seconds:
 - This clip is protected and can't be cleared. (if the clip is eligible for CLEAR)
 - Some clips are protected and can't be cleared. (If protected clip is included in the eligible Page/BANK)
- To delete a protected clip playlist, unprotect it and delete it, or run SSD Initialize (Disk Format).
- Clip protection is performed and deprotected simultaneously for all channels A/B/C/D.
- If a playlist is protected, the clips contained in the playlist are not protected.
- The judgment time of the long press shall be about 1 second.

4.7.1 Protecting clips (and playlists)

- To protect clips (and playlists), follow these steps:

- As an example here, suppose that the clip is registered with the same Page, BANK, and clip numbers as in the example shown in [\[4.5.1\]](#).
- Protect operations are performed in BANK8 of Page 9.

- 1 Follow the instructions in [\[4.5.1\]](#) , and specify Page, BANK.

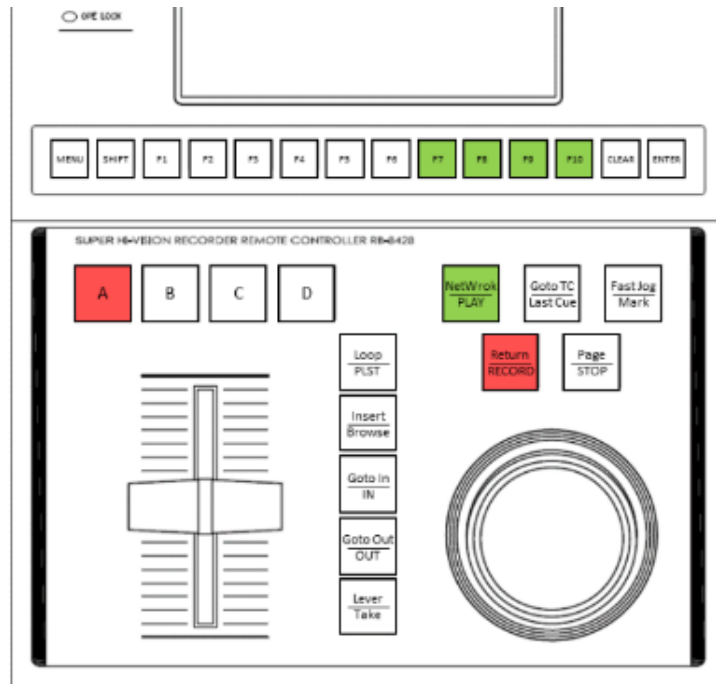

- 2 Press the **[F1] ~ [F10]** button that lights up green with <<long press>>. Then the clip with the corresponding clip number is protected.

- As an example, when protecting Clip 8, a pop-up with the following image will appear on the LCD for 2 seconds:

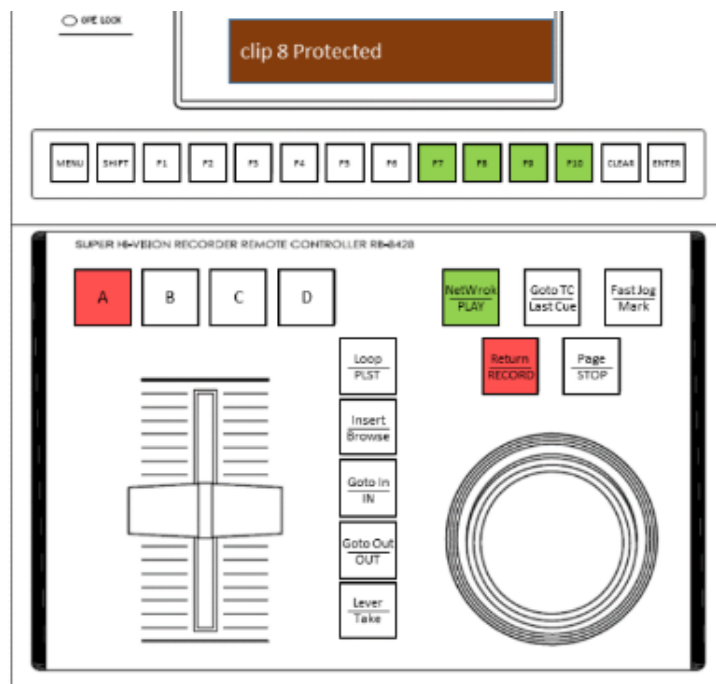

3 If you want to protect another clip continuously, press the **[F1] ~ [F10]** button that lights up green with <<long press>>. Then the clip with the corresponding clip number is protected.

- As an example, when protecting a new clip 9, a pop-up with the following image will appear on the LCD for 2 seconds:

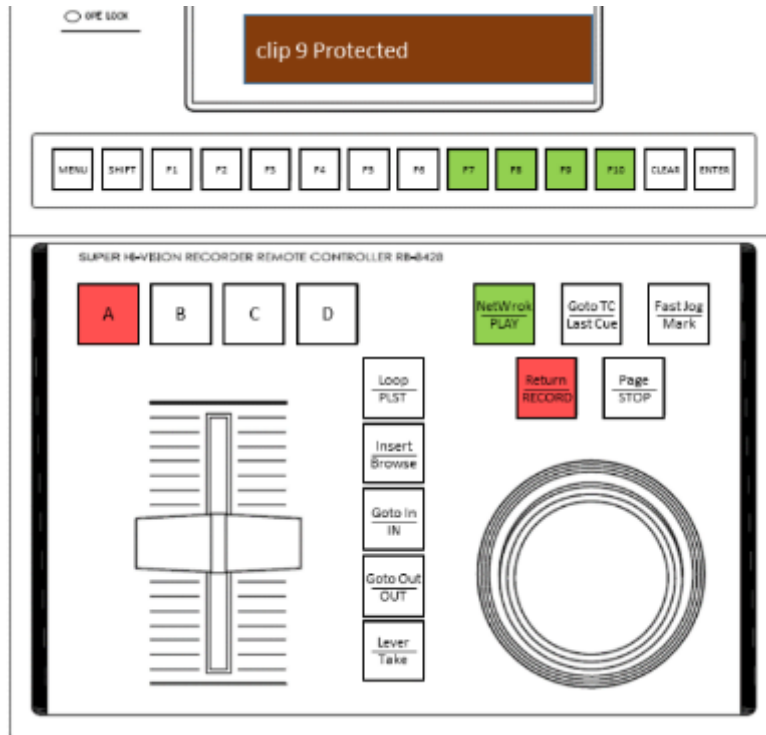

4 To unprotect a clip, press the **[F1] ~ [F10]** button that lights up green with <<long press>>. Then the clip with the corresponding clip number is unprotected.

- As an example, when unprotecting clip 8, a pop-up with the following image will appear on the LCD for 2 seconds:

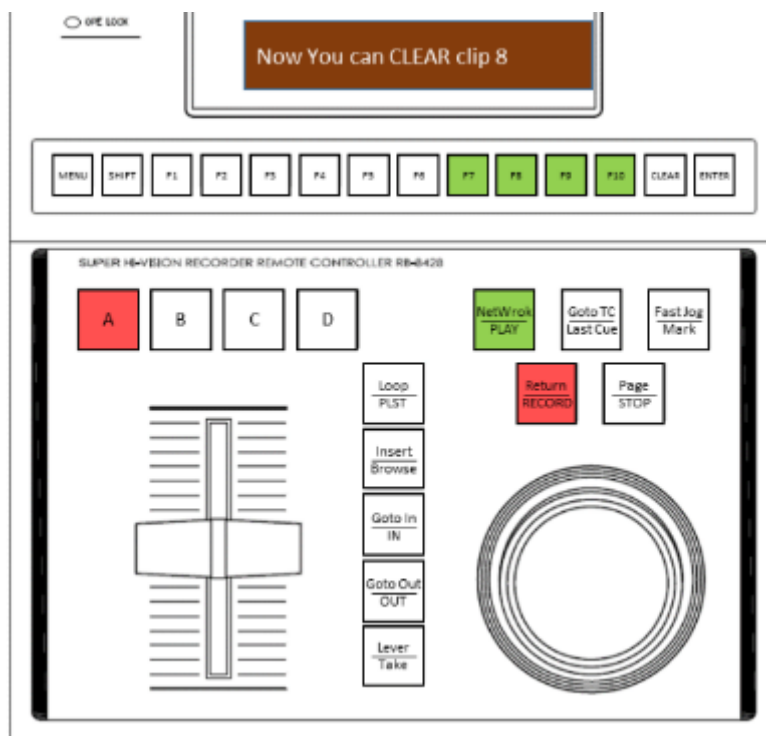

5 If the clip you want to unprotect is included in a protected playlist, the following pop-up warning appears:

- As an example, if clip 1 is included in a protected playlist, a pop-up with the image below will appear on the LCD for 2 seconds.

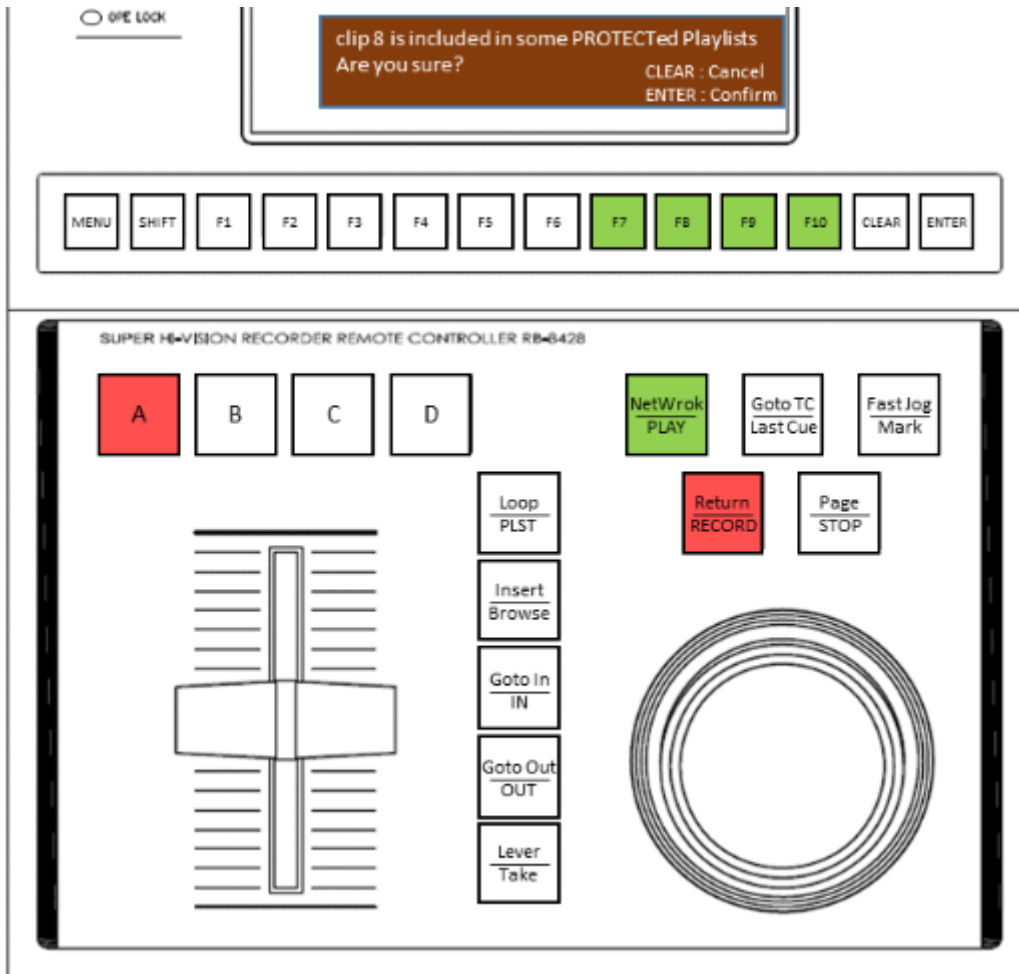

4.7.2 Batch protection of clips included in BANK

- To batch protect clips included in BANK, follow these steps:
 - As an example here, suppose that the clip is registered with the same Page, BANK, and clip numbers as in the example shown in [\[4.5.1\]](#).
 - Protect operation is performed in Page9.
- 1** Follow the steps in [\[4.5.1\]](#) to move to the BANK selection tier.

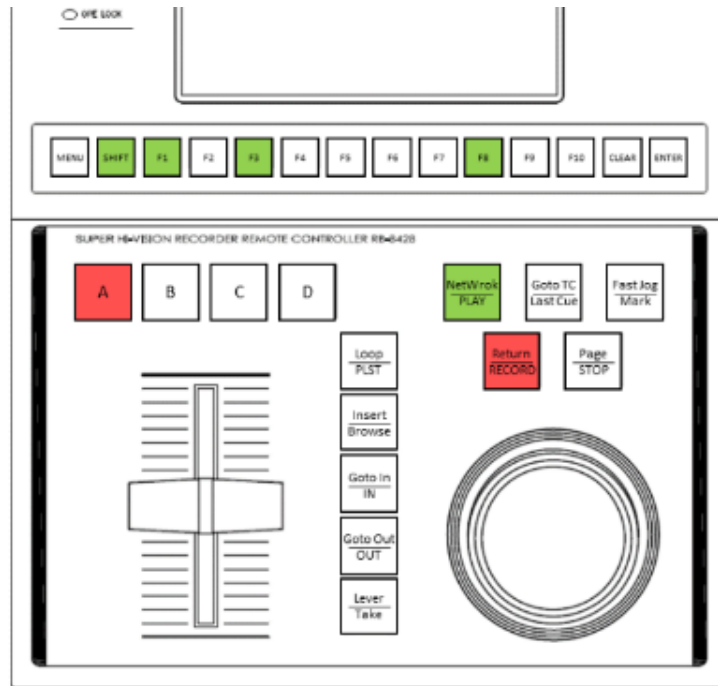

- 2** Press the **[F1] ~ [F10]** button that lights up green with <<long press>>. Then the **BANK** with the corresponding **BANK** number is protected.

- As an example, when protecting BANK8, a pop-up with the following image will appear on the LCD for 2 seconds.

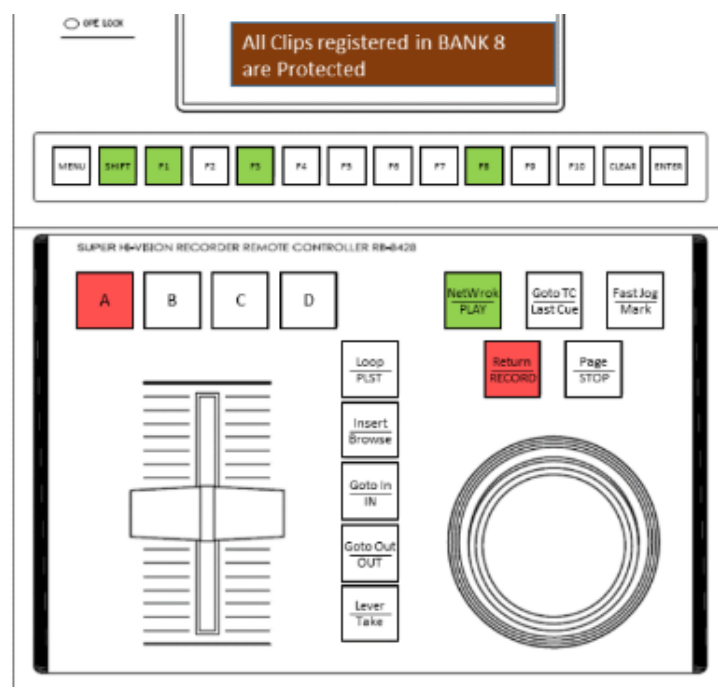

3 If you want to protect another BANK continuously, press the **[F1] ~ [F10]** button that lights up green with <<long press>>. Then the BANK with the corresponding BANK number is protected.

- As an example, when protecting a new BANK1, a pop-up with the following image will be displayed on the LCD for 2 seconds.

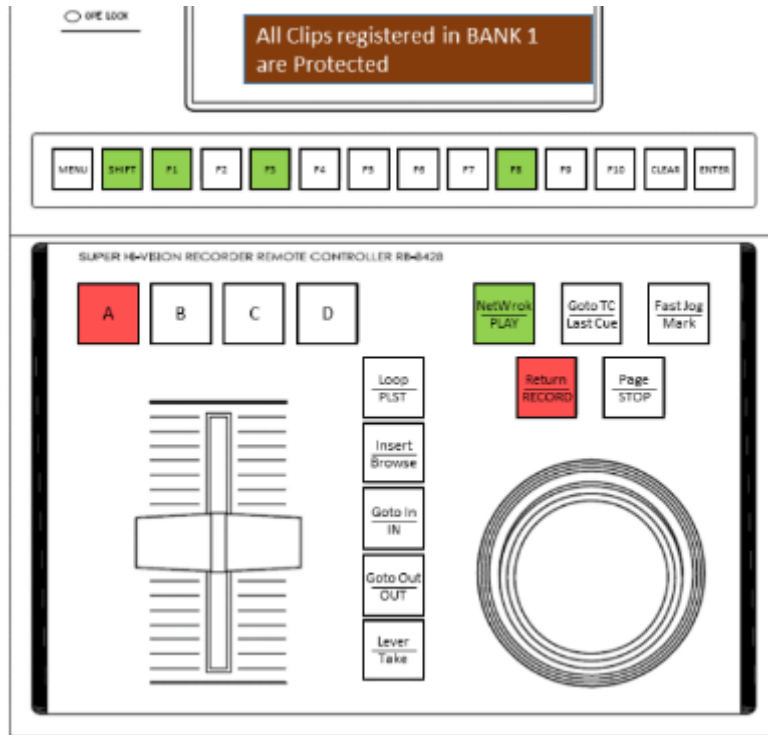

4 To remove the protection of BANK, press the **[F1] ~ [F10]** button that lights up green with <<long press>>. Then the BANK with the corresponding BANK number is unprotected.

- As an example, when unprotecting BANK8, a pop-up with the following image will appear on the LCD for 2 seconds:

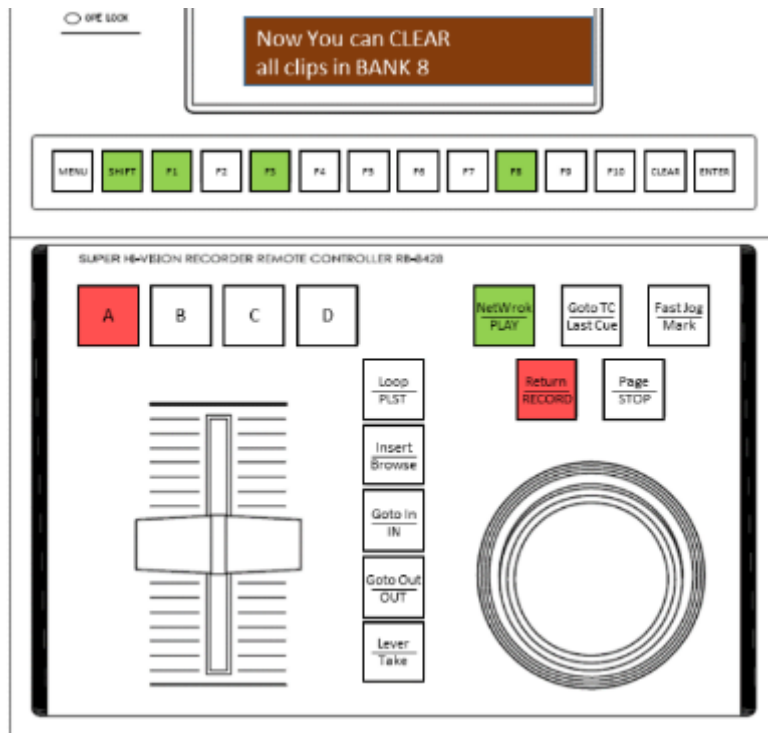

5 If the BANK that tries to unprotect all at once has clips included in the protected playlist, the following pop-up warning will be displayed.

- As an example, if clip 1 is included in a protected playlist, a pop-up with the image below will appear on the LCD for 2 seconds.

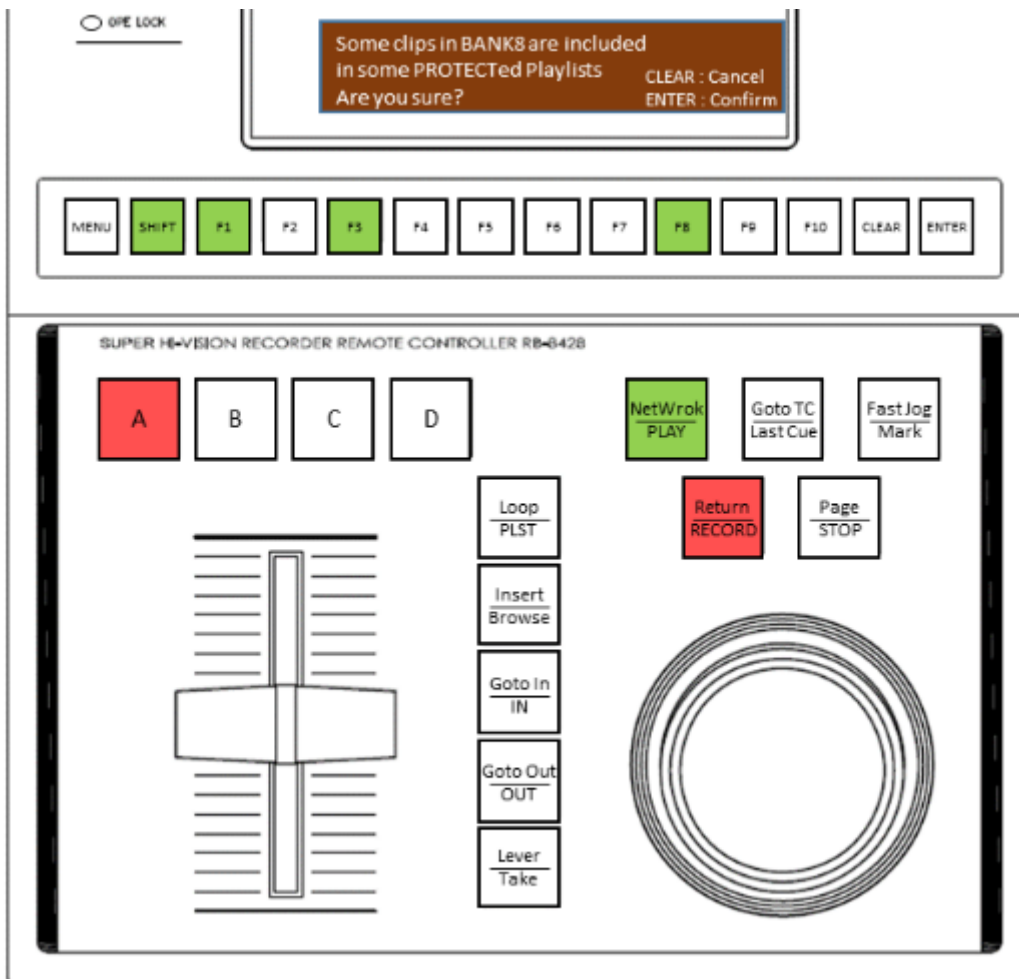

4.7.3 Batch protection of clips (and playlists) included in the Page

- To batch protect clips contained in Page, follow these steps:
 - As an example here, suppose that the clip is registered with the same Page, BANK, and clip numbers as in the example shown in [\[4.5.1\]](#).
- 1** Follow the steps in [\[4.5.1\]](#) to transition to the Page selection hierarchy.

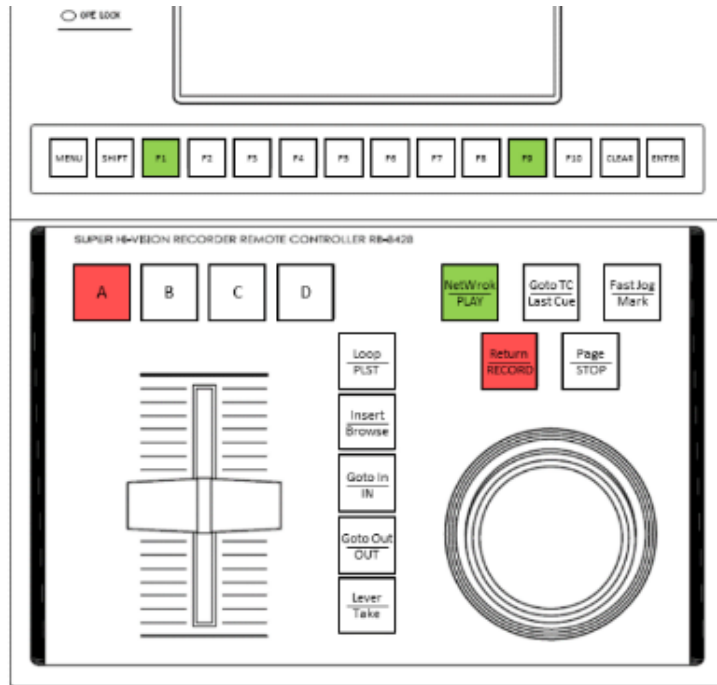

- 2** Press the [F1] ~ [F10] button that lights up green with <<long press>>. Then the Page with the corresponding Page number is protected.

- As an example, when protecting Page9, a pop-up similar to the following image will be displayed on the LCD for 2 seconds.

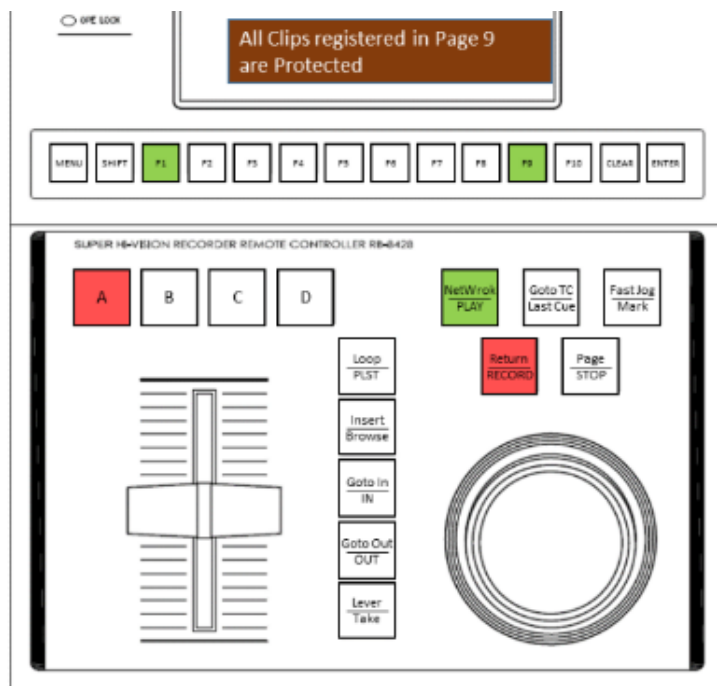

- 3** If you want to protect another Page continuously, press the **[F1] ~ [F10]** button that lights up green with <<long press>>. Then the Page with the corresponding Page number is protected.
- As an example, when protecting Page1 anew, a pop-up with the following image will be displayed on the LCD for 2 seconds.

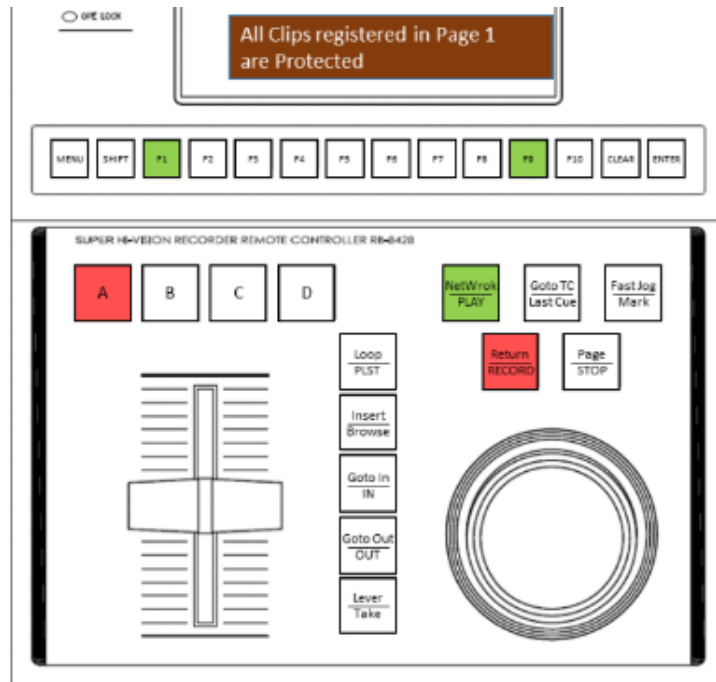

- 4** To remove the protection of Page, press the **[F1] ~ [F10]** button that lights up green with <<long press>>. Then the Page with the corresponding Page number is unprotected.
- As an example, when unprotecting Page 9, a pop-up with the following image will appear on the LCD for 2 seconds.

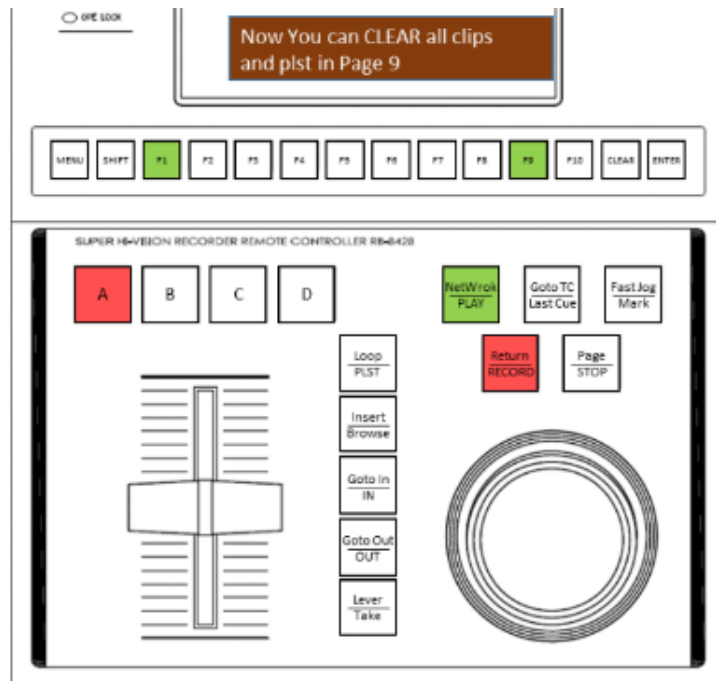

5 If a page that tries to unprotect all at once has clips registered in a protected playlist, the following pop-up warning will be displayed.

- As an example, if clip 1 is included in a protected playlist, a pop-up with the image below will appear on the LCD for 2 seconds.

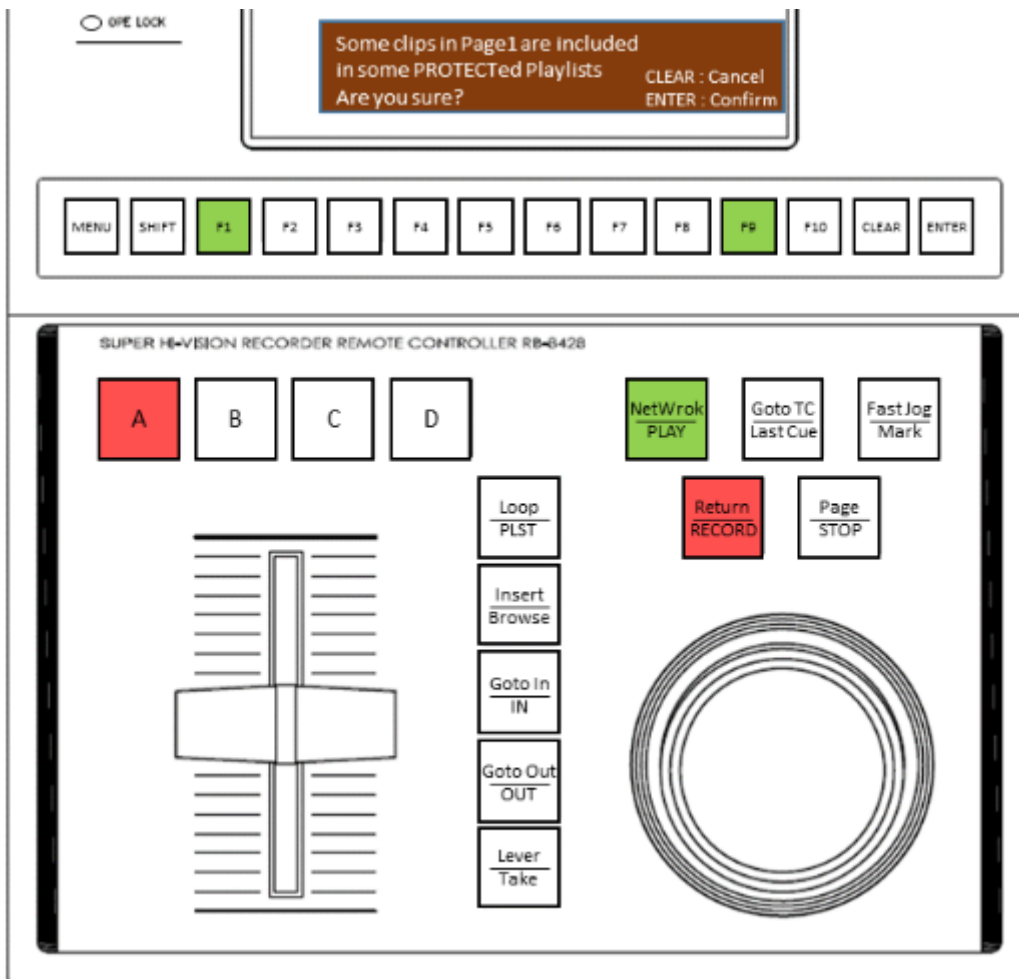

4.7.4 Checking protected clips (and playlists)

- To see protected clip playlists, complete the following steps:

- As an example, suppose that a clip is registered in the Page, BANK, and clip numbers shown in [\[4.5.1\]](#) , and it is in the state after the following operations are performed.
 - ① clip 6 in BANK 3 in Page 9 was protected.
 - ② BANK 8 in Page 9 was protected.
 - ③ Page1 was protected.
 - ④ After the operation of ① ~ ③, not a single additional clip has been registered.

1 Press the **[SHIFT]** button with <<long press>> to enter the protection confirmation mode.

- The **[CLEAR]** button will light up yellow and a cautionary message in the image below will appear on the LCD.

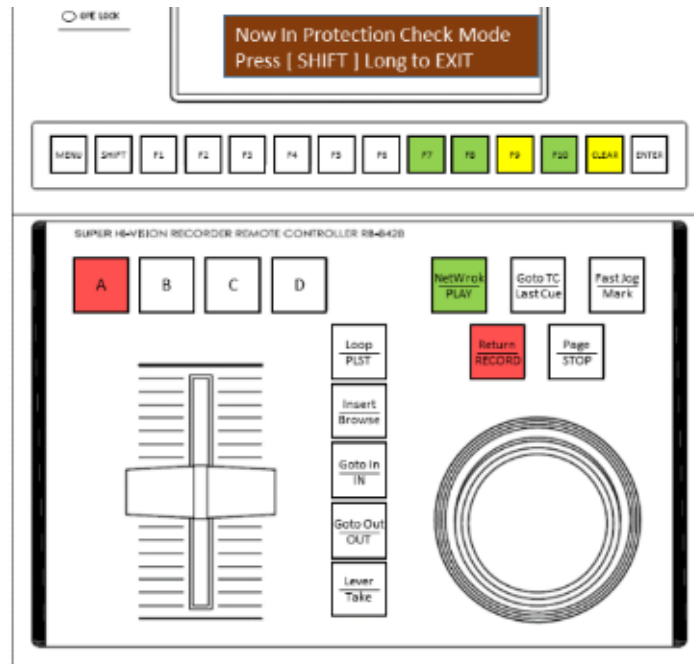

2 Follow the instructions in [\[4.5.1\]](#) , and specify Page, BANK.

- As an example, since clip 6 of Page 9 / BANK 3 is protected, the **[F6]** button lights up yellow.

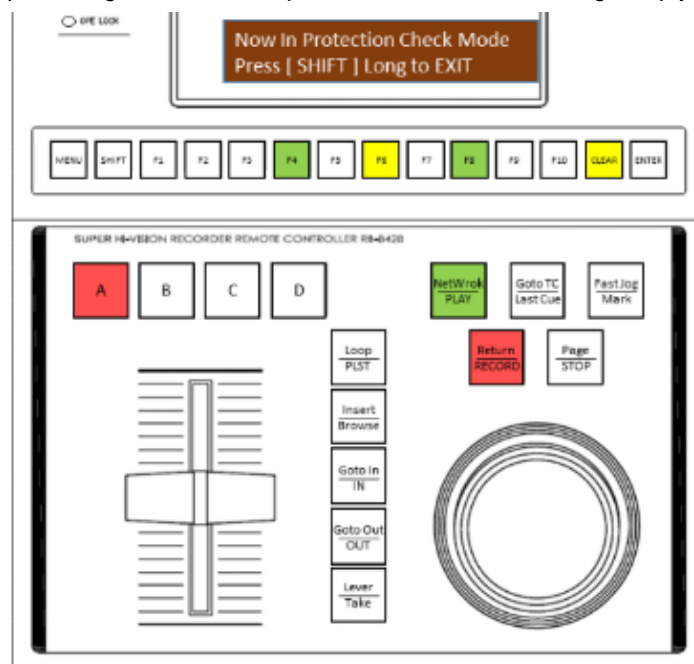

3 **[4.5.1]** Follow the steps in to move to the BANK selection tier.

- As an example, because BANK 8 of Page 9 is protected, the **[F8]** button lights up yellow.

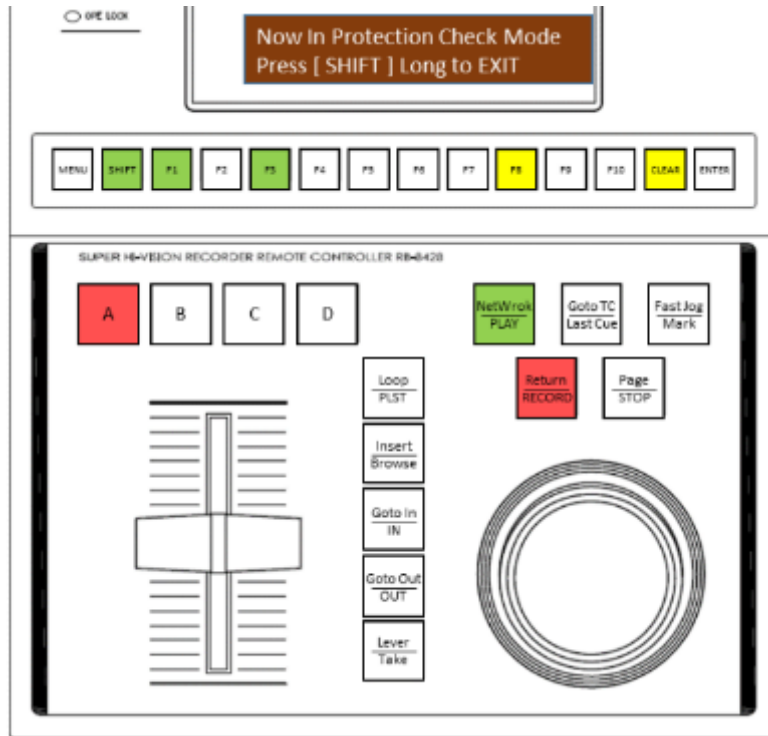

- After this, if a new clip is registered in BANK 8 of Page 9, the **[F8]** button will light up green because some clips are not protected.

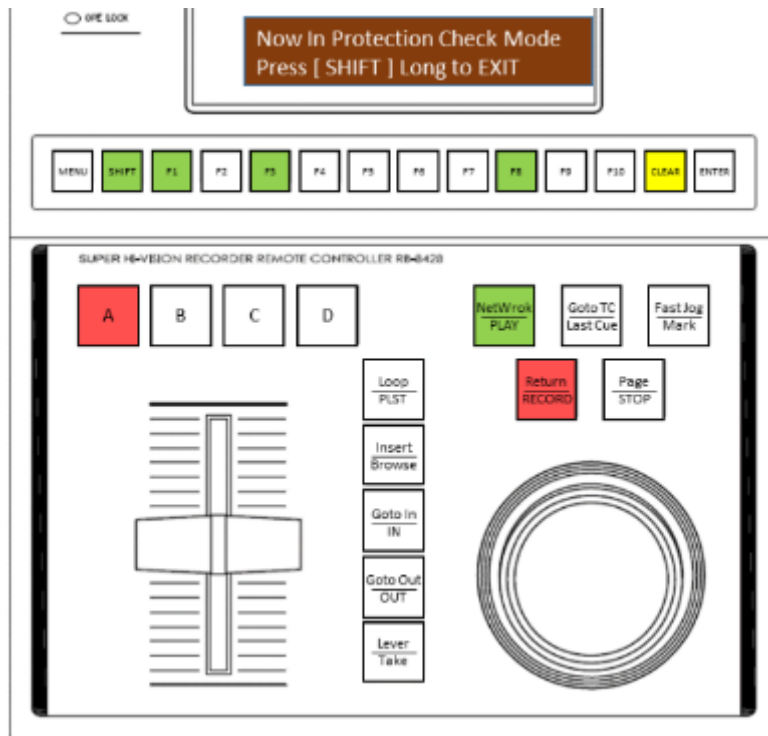

4 Follow the steps in [4.5.1](#) to transition to the Page selection hierarchy.

- As an example, because Page1 is protected, the **[F1]** button lights yellow.

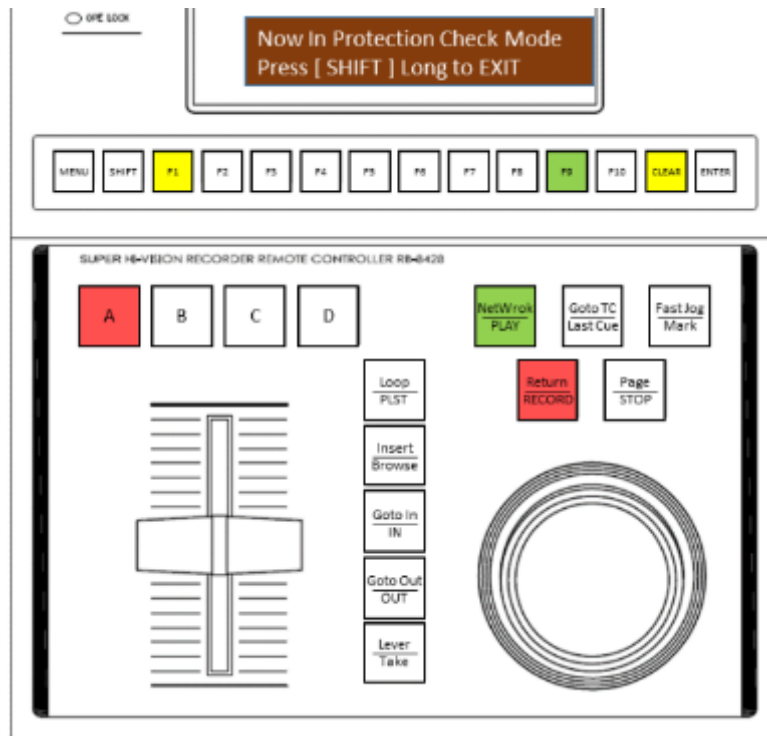

- After this, if you register a new clip in BANK of Page 1, the **[F1]** button will light up green because some clips are not protected.

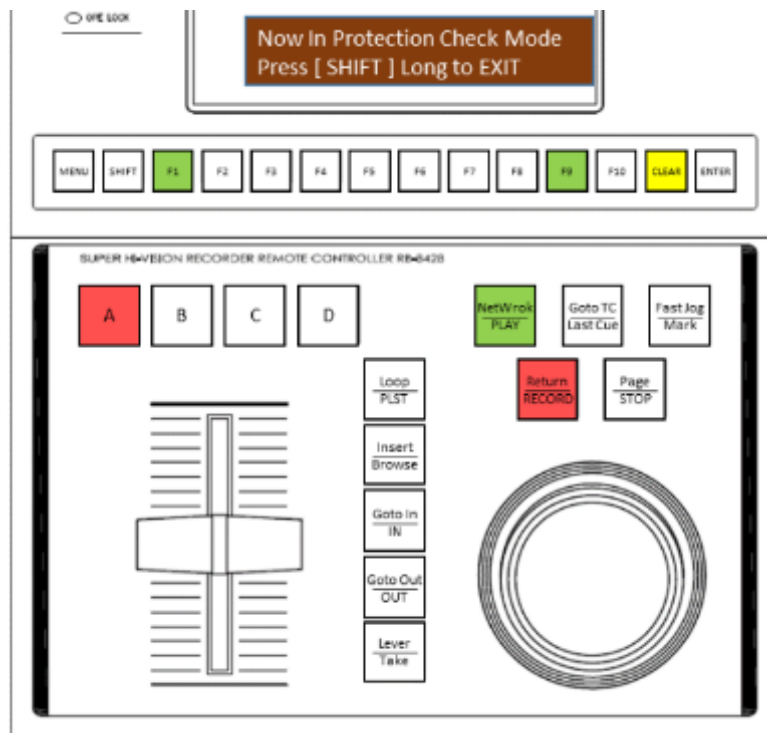

5 Press the **[Return/RECORD]** button or press the **[SHIFT]** button with <<long press>> to exit the protection confirmation mode.

- **[CLEAR]**The button is off and protected. The **[F1] ~ [F10]** button lights up green. The caution message is also cleared from the LCD.

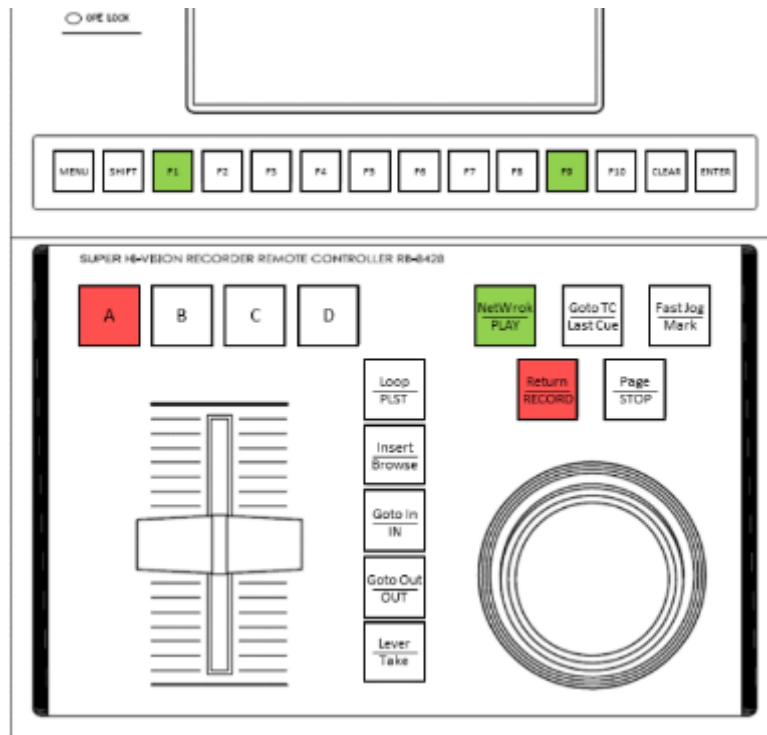

MEMO

- **While transitioning to Protect Confirmation Mode, Other than the operations described in "Operation 4. 7. 1 (p44)" and later, only the following operations are permitted, and all other operations are prohibited.**
 - Cue Up Clip Playlist
 - PLAY slow playback of clip playlists
 - JOG search in clips and playlists

4.8 MENU

- In the MENU hierarchy, pressing the **[CLEAR]** button returns to the next higher level, and pressing the **[MENU]** button completely exits from the MENU screen.
- The currently selected setting is displayed in blue shading.
- If **[CLEAR: Return]** is displayed on the LCD screen, it will be reflected at the time of selection. If **[CLEAR: Cancel]** or **[ENTER: Set]** are displayed, the setting is canceled in **[CLEAR]** and reflected in **[ENTER]**.

Tier 1	Tier 2	Tier 3	Setting value / process (initial setting: underline)	explanation
[F1] ...	SSD Pack			
	[F1] ... Disk Format	[ENTER] ... OK		In the pop-up that appears again, press the [F5] button and the [F6] button at the same time to fully format the SSD.
		[CLEAR] ... Cancel		
[F2] ...	Video INPUT			
	[F1] ... Video Input Mode	[F1] ... <u>60P 4-Input</u>		60p 4 system input with 4 hours recording mode
		[F2] ... 60P 2-Input		60p 2 system input Switch the recording mode for 8 hours.
[F3] ...	Genlock Input			
		[F1] ... Video Input		Synchronizes to the input signal.
		[F2] ... Ref Input		Synchronizes to an external reference signal.
[F4] ...	Phase			
	[F1] ... H Phase	[Jog] ...-1099- <u>0</u> ~1100		Adjust the horizontal phase.
	[F2] ... V Phase	[Jog] ...-562- <u>0</u> ~562		Adjust the vertical phase.
[F5] ...	Audio In/Out			
	[F1] ... Audio In	<u>[F1] ... MADI IN</u>		Records the audio input from MADI IN.
		[F2] ... SDI Embedded Audio		Records audio multiplexed in the SDI input.
	[F2] ... 4K Out CH Assign 1	[F1] ~ [F10] ... Audio ch		See the note "About AudioCHAssign" below.
	[F3] ... HD Out CH Assign 2	[Jog] ... 1~32		
[F6] ...	Timecode			
	[F1] ... Input	<u>[F1] ... TC IN</u>		Record the timecode entered in TC IN.
		[F2] ... SDI Embedded VITC		Includes multiplexed VITCs in the SDI input.
		[F3] ... SDI Embedded LTC		Includes multiplexed LTCs in the SDI input.
		[F4] ... Internal		Contains internally generated timecode.
	[F2] ... DF/NDF	<u>[F1] ... DF</u>		Switch between drop and non-drop frames.
		[F2] ... NDF		
	[F3] ... Internal TC Mode	<u>[F1] ... Time of day</u>		Generates internal timecode from the current time.
		[F2] ... Freerun		The value counted by self-propelled from the set initial value is set as the internal generation timecode.
	[F4] ... Initial Value			
	<u>[F1] ... Value</u>	[F1] ~ [F10] ... hh:mm:ss		Set the initial value of Free Run timecode.
	[F2] ... Initialize	[ENTER] ... OK		Reset the Free Run timecode to the initial value set in the above item.
		[CLEAR] ... Cancel		
[F7] ...	OSD Display			
	[F1] ... EE Character	[F1] ... ON/OFF		Displays and hides overlapping character information on the EE screen.
	[F2] ... PB Character	[F2] ... ON/OFF		Display or hide overlapping character information on the PB screen.
	[F3] ... Audio meter	[F3] ... ON/OFF		Show or hide overlapping audio level meters on each screen.

Tier 1	Tier 2	Tier 3	Setting value / process (initial setting: underline)	explanation
[F8] ...	MARK Delete			
	[F1] ... All		[ENTER] ... OK [CLEAR] ... Cancel	Delete all MARK points.
			[F2] ... Latest Point [F3] ... Oldest Point	Delete the newest MARK point. Delete the oldest MARK point.
[F9] ...	System			
	[F1] ... Clock		[F1] ~ [F5] ... YY/MM/DD hh : mm : ss	Set the time on the built-in clock of this device.
	[F2] ... Memory			
	[F1] ... Save [F2] ... Load		[F1] ~ [F5] ... Memory No. [F1] ~ [F5] ... Memory No.	Saves the settings to memory. Calls the setting value from memory.
	[F8] ... Factory Default		[ENTER] ... OK [CLEAR] ... Cancel	Restore all settings to factory defaults.
	[F3] ... Guard Time		[F1] ~ [F10] ... ss (up to 30 seconds) Initial value... 30	Sets the time of the additional protection area (guard band) before and after the registered clip. See note below (about guard bands)
	[F4] ... Postroll Time		[F1] ~ [F10] ... ss (up to 30 seconds) Initial value... 30	Set the time for the post roll.
	[F6] ... Play Back Speed		[F1] ... 100% [F2] ... 75% [F3] ... 50% [F4] ... 25%	Press the [PLAY] button to set the playback speed when playing. Applies during Play Back mode and Clip playback.
[F10] ...	Information			Displays version information for the remote controller.

✧ About Audio CH Assign

When you select **【4K Audio Assign】** or **【HD Audio Assign】** in MENU, the following screen is displayed on the LCD of the remote controller. Each notation has the following meanings: In the example below, the embedded audio CH 1 and CH2 are assigned the recorded audio CH 25 and CH26, respectively.

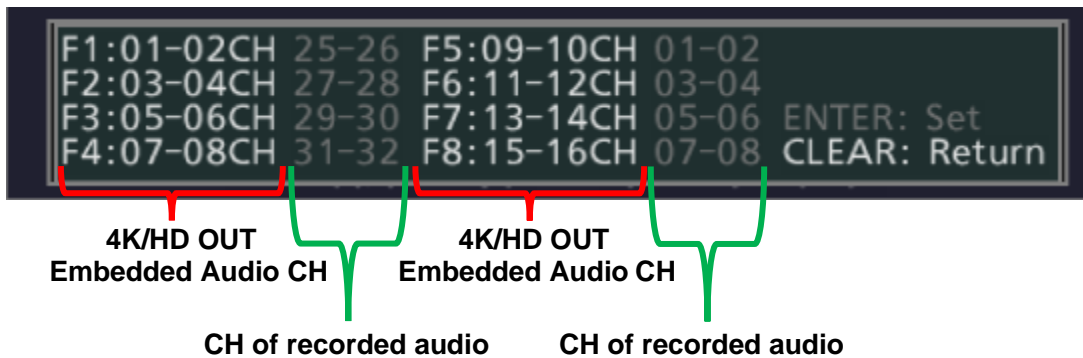

● To configure Audio CH Assign, complete the following steps:

- 1 Enter the **【F1】** ~ **【F8】** button corresponding to the Audio CH you want to change.
- 2 **【Jog】** and select a audio assignment.
- 3 **【ENTER】**button Press to reflect the audio assignment. **【CLEAR】** to cancel it.

The initial values for audio assignments for each SDI OUT are as follows:

SDI OUT Audio CH	1	2	3	4	5	6	7	8	9	10	11	12	13	14	15	16
4K Audio Assign	25	26	27	28	29	30	31	32	1	2	3	4	5	6	7	8
HD Audio Assign	31	32	29	30	27	28	25	26	23	24	21	22	19	20	17	18

✧ About Guard Band

When **【Guard Time】** is set in MENU, a protective area (guard band) is also provided before and after the clip when a clip is registered. Editing the IN/OUT points of a clip is only possible within this range.

Also, if **【Postroll Time】** is set, playback continues even after exceeding the OUT point according to the setting value (except when playing Loop). **【Postroll Time】** cannot exceed **【Guard Time】**.

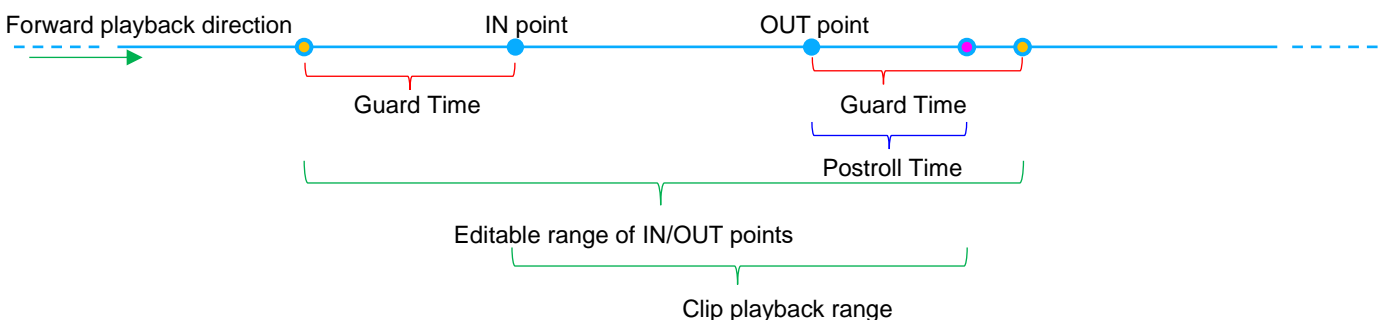

Chapter 5 When you are in trouble

This chapter describes how to respond when this device does not operate normally.

5.1 If it doesn't work properly

If this device does not operate properly, please refer to the following table and take appropriate measures.

If the problem still persists, please contact your dealer or the business department of ASTRODESIGN, Inc.

This device SR-8450	
symptoms	cope
The output video is distorted.	<ul style="list-style-type: none"> ➤ On the HOME screen of the touch panel LCD, check that the SDI status is set to 【Locked】.

Remote Controller RB-8428			
symptoms	cope		
<table border="1"> <tr> <td>button</td> <td>unresponsive</td> </tr> </table>	button	unresponsive	<ul style="list-style-type: none"> ➤ Make sure the COMM LED lights up. <ul style="list-style-type: none"> ✓ If it does not light up, verify that the BNC cable between the SR-8450 and RB-8428 REMOTE terminals is connected properly. ➤ Check whether the SR-8450 is causing SSD errors etc. at startup.
button	unresponsive		

5.2 When an abnormality or malfunction occurs

Discontinue use, unplug the power cord, and contact the dealer or the business department of ASTRODESIGN, Inc.

Chapter 6 Device Specifications

This chapter describes the specifications of the device.

6.1 This device SR-8450

6.1.1 Main unit specifications

item		specification
8K video input		12G-SDI(SMPTE ST 2082-12) 4 inputs 7680x4320 YC _B C _R 4:2:2 59.94p 10bit TYPE1 Embedded Audio Timecode
8K video output		12G-SDI(SMPTE ST 2082-12) 2 outputs 7680x4320 YC _B C _R 4:2:2 59.94p 10bit TYPE1 Supports embedded audio and timecode ancillary data (audio, TC)
4K video output		12G-SDI(SMPTE ST 2082-10) 2 outputs 3840x2160 59.94p 10bit TYPE1 Embedded Audio Timecode
HD output		HD-SDI(SMPTE 292M) 5 outputs (EEx1/PBx2/LINEx2) 1920x1080 59.94i Embedded Audio Timecode
Sync signal input		HD3-value/BB signal 75Ω BNC passive through-the-clock *Auto-termination not supported
MADI I/O		75Ω BNC 4 inputs and 2 outputs
TIMECODE I/O		BNC LTC 1 input, 2 outputs
REMOTE		BNC connector 75Ω 2 ports
SD slot		SD card slot (for maintenance)
10GbE LAN(RJ45)		10Gbps SFP+ connector (future expansion port)
Recording method	Video method recording	Grass Valley HQX Codec YC _B C _R 4:2:2 10bit Intraframe Compression
	Audio method recording	Linear PCM 48kHz 24bit 32 audio channels
Recording Media		SSD 32 TB total (8TB per unit) #hot swap unsupported
Recording time		4 input modes: Up to 4 hours per input system 2 input modes: Up to 8 hours per input system
General Specifications	Power supply voltage	AC100V-240V
	Operating temperature range	0°C ~ 40°C
	Operating humidity range	20 ~ 80% RH (non-condensing)
	Power Consumption	700W
	Dimensions	5U rackmount size (430 × 222 × 500mm) *Does not include protrusions
	Weight	25kg

6.1.2 appearance

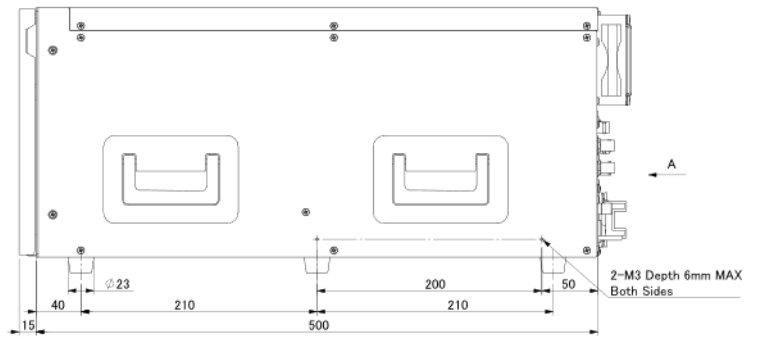
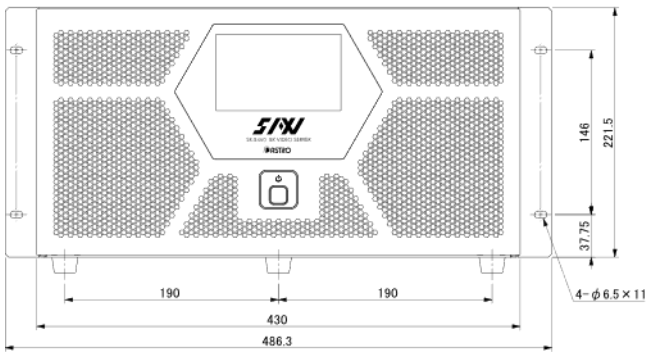
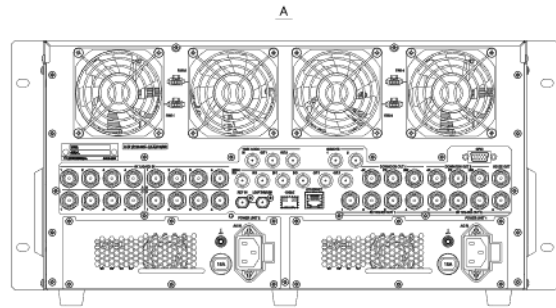
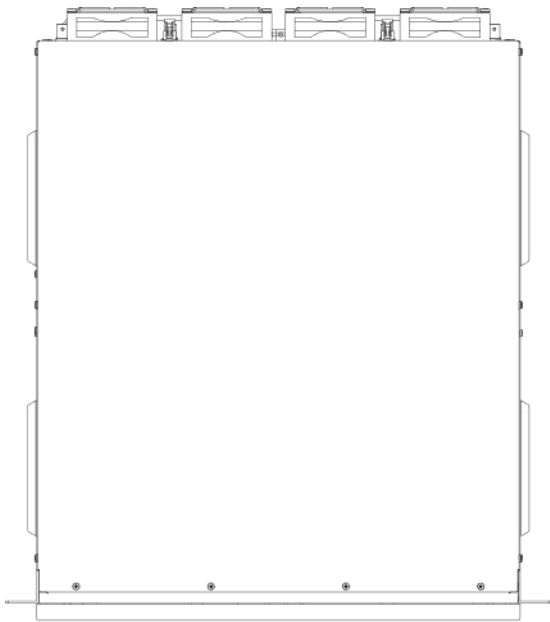

6.2 Remote Controller RB-8428

6.2.1 Main unit specifications

item		specification
REMOTE		BNC connector 75Ω Remote control terminal
General Specifications	Power supply voltage	AC100V-240V
	Operating temperature range	0°C ~ 40°C
	Operating humidity range	20 ~ 80% RH (non-condensing)
	Power Consumption	15W
	Dimensions	210(W) × 54.5 – 149(H) × 255.3(D) mm (not including protrusions)
	Weight	1.6kg

6.2.2 appearance

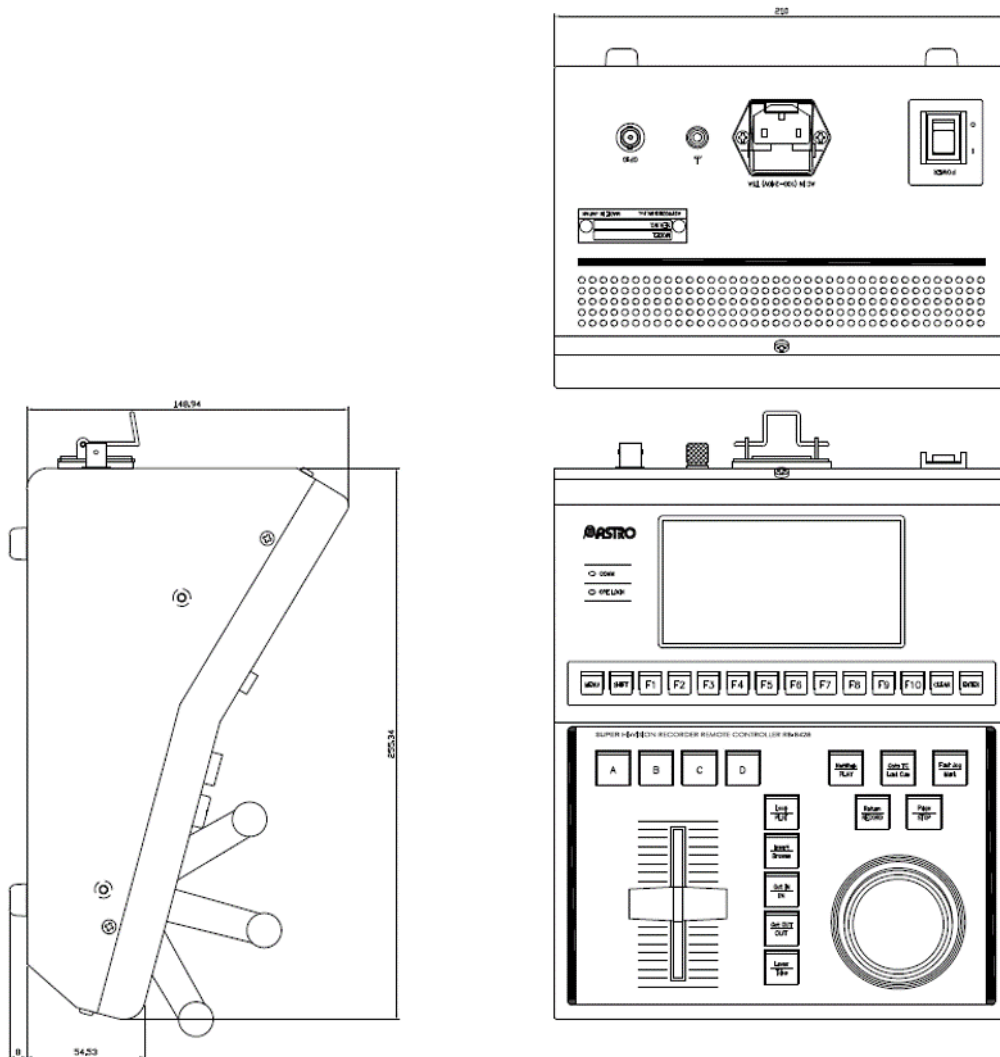

Chapter 7 Changelog

Ver.	date	page	item number	explanation
1.00	2020/03/16			first edition
1.20	2022/10/25	13	2.1.1	Change of description
		15	2.1.2	
		16	2.1.5	
		18	3.3.1	Change attached image
		21	3.2.1	
		22	3.3	
		28	4.3	
			4.4	Added operations on GotoTC points
		36	4.5.7	Erase and add BANK-based clips/playlists
			4.5.8	PAdd erase clips per AGE
		39	4.6.7	Add editing the playback speed of clips in a playlist
		40	4.6.8	Add Transition Type settings for clips in a playlist
		41	4.6.9	Add Transition Duration settings for clips in a playlist
		42	4.6.10	Add Transition Color settings for clips in a playlist
		43-56	4.7	Added features of the protect function
		57	4.8	【F8】 ... MARK Delete appendix
61	6.1.1	Change of description		

SR-8450**Operation Manual Ver. 1.20**

- We will replace the Falling Ding Book and the Random Ding Book.
- The copyright of this book belongs to ASTRODESIGN, Inc.
- All or part of the description of this document may not be used or reproduced without permission.
- The information in this document is subject to change without notice for improvement.
- Please note that we are not responsible for the impact of incorrect use results.
- For inquiries about this product, please contact the dealer where you purchased it or the following.
- The products and trade names mentioned herein are trademarks or registered trademarks of their respective companies.

D0710**2022.10**

ASTRODESIGN, Inc.<https://www.astrodesign.co.jp>

- For more information, please contact us :

TOKYO Headquarters**TEL +81-(0)3-5734-6320 FAX +81-(0)3-5734-6102**

1-5-2 Minami-yukigaya, Ota-ku, Tokyo, Japan 145-0066

USA OFFICE**TEL +1-408-435-7800 FAX +1-408-435-7900**

780 Montague Expressway, Suite 302, San Jose CA 95131 USA