

geratech[®]



EGE-CT-12

Digital Optical Audio Splitter



DISCLAIMERS

The information in this manual has been carefully checked and is believed to be accurate. Geratech assumes no responsibility for any infringements of patents or other rights of third parties which may result from its use. Geratech assumes no responsibility for any inaccuracies that may be contained in this document. Geratech also makes no commitment to update or to keep current the information contained in this document. Geratech reserves the right to make improvements to this document and/or product at any time and without notice.

COPYRIGHT NOTICE

No part of this document may be reproduced, transmitted, transcribed, stored in a retrieval system, or any of its part translated into any language or computer file, in any form or by any means— electronic, mechanical, magnetic, optical, chemical, manual, or otherwise— without express written permission and consent from

Geratech.

© Copyright 2011 by Geratech.

All Rights Reserved.

Version 1.1 August 2011

TRADEMARK ACKNOWLEDGMENTS

All products or service names mentioned in this document may be trademarks of the companies with which they are associated.

SAFETY PRECAUTIONS

Please read all instructions before attempting to unpack, install or operate this equipment and before connecting the power supply.

Please keep the following in mind as you unpack and install this equipment:

- Always follow basic safety precautions to reduce the risk of fire, electrical shock and injury to persons.
- To prevent fire or shock hazard, do not expose the unit to rain, moisture or install this product near water.
- Never spill liquid of any kind on or into this product.
- Never push an object of any kind into this product through any openings or empty slots in the unit, as you may damage parts inside the unit.
- Do not attach the power supply cabling to building surfaces.
- Use only the supplied power supply unit (PSU). Do not use the PSU if it is damaged.
- Do not allow anything to rest on the power cabling or allow any weight to be placed upon it or any person walk on it.
- To protect the unit from overheating, do not block any vents or openings in the unit housing that provide ventilation and allow for sufficient space for air to circulate around the unit.

REVISION HISTORY

VERSION NO.	DATE DD/MM/YY	SUMMARY OF CHANGE
VR0	11/01/08	Preliminary Release
VS1	24/06/13	Updated format/diagrams

CONTENTS

1. INTRODUCTION 1

2. APPLICATIONS 1

3. PACKAGE CONTENTS 1

4. SYSTEM REQUIREMENTS 1

5. FEATURES 1

6. OPERATION CONTROLS AND FUNCTIONS 2

6.1 Front Panel..... 2

6.2 Rear Panel..... 2

6.3 Left Panel 3

6.4 TopPanel..... 3

7. CONNECTION DIAGRAM 4

8. SPECIFICATIONS..... 5

9. ACRONYMS..... 5



1. INTRODUCTION

The Optical Digital Audio Splitter can split a single optical digital input to two outputs to lengths of up to 5m, using TosLink optical cables, reliably and without loss of quality. It is designed to be compact, easy to install and use making it ideal for home or professional audio distribution.

2. APPLICATIONS

- Split a single optical digital input to two outputs
- Distribute an optical digital audio source to multiple AV Receivers
- Distribute an optical digital audio sources to AV Receiver and Audio over CAT extender simultaneously

3. PACKAGE CONTENTS

- 1xDigital Optical Audio Switcher
- 1x5V DC Power Supply

4. SYSTEM REQUIREMENTS

Source devices such as DVD or Blu-Ray players with an optical digital output and AV Receivers or Active speakers with optical digital inputs and optical cables.

5. FEATURES

- Supports the S/PDIF standard of digital audio transmission
- Supports uncompressed 2-channel LPCM (Linear Pulse Code Modulation) audio signal
- Supports compressed 2-channel and multi-channel Dolby Digital and DTS audio signals
- Provides electromagnetic-noise-free transmission
- Easy to install and to operate

6. OPERATION CONTROLS AND FUNCTIONS

6.1 Front Panel

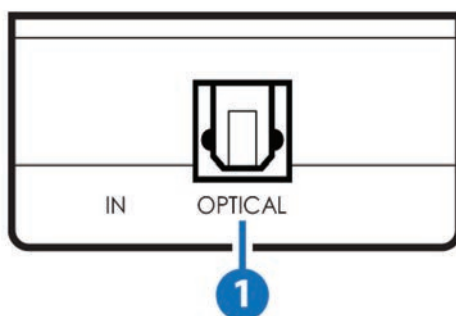

1 OPTICAL IN

Connect the TOSLink input port to the TOSLink output of source equipment such as games console, set-top box or DVD player.

6.2 Rear Panel

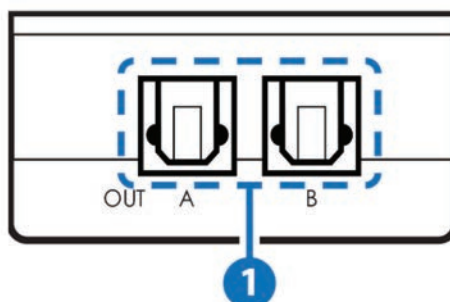

1 OPTICAL OUT A/B

Connect the TOSLink outputs to the TOSLink inputs of audio equipment such as an AV receiver or active speakers.

6.3 Left Panel

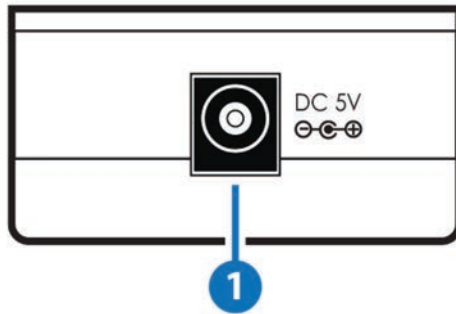

1 DC 5V

Connect the 5V DC power supply to the unit and plug the adaptor into an AC wall outlet.

6.4 Top Panel

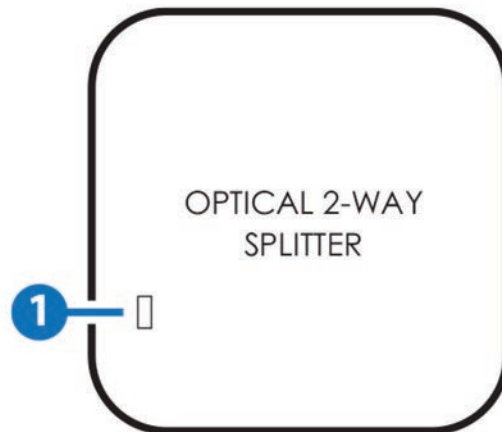

1 Power LED

The LED will illuminate when connected to a power supply.

7. CONNECTION DIAGRAM

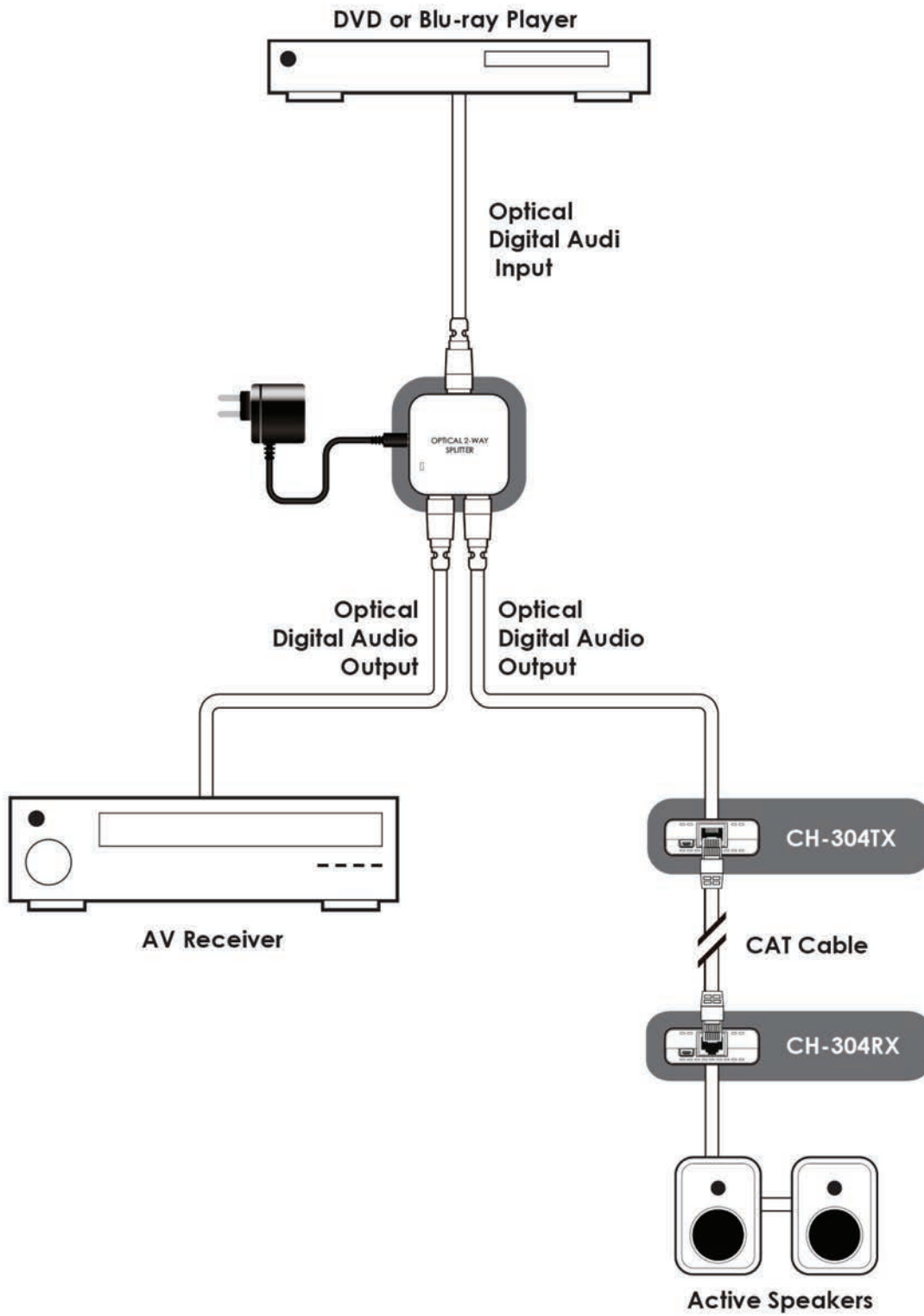

8. SPECIFICATIONS

Input Ports	1×Optical (TOSLink)
Output Ports	2×Optical (TOSLink)
Power Supply	5 V/0.5 A or 0.36 A DC (US/EU standards, CE/FCC/UL certified)
Dimensions	46 mm (W)×45.5 mm (D)×23.5 mm (H)
Weight	22 g
Chassis Material	Plastic
Silkscreen Color	White
Operating Temperature	0 °C ~ 40 °C

9. ACRONYMS

ACRONYM	COMPLETE TERM
DTS	Digital Theater Systems
LPCM	Linear Pulse Code Modulation
S/PDIF	Sony/Philips Digital Interconnect Format
TOSLINK	Toshiba Link



www.egerate.com

www.geratech.eu