

geratech®

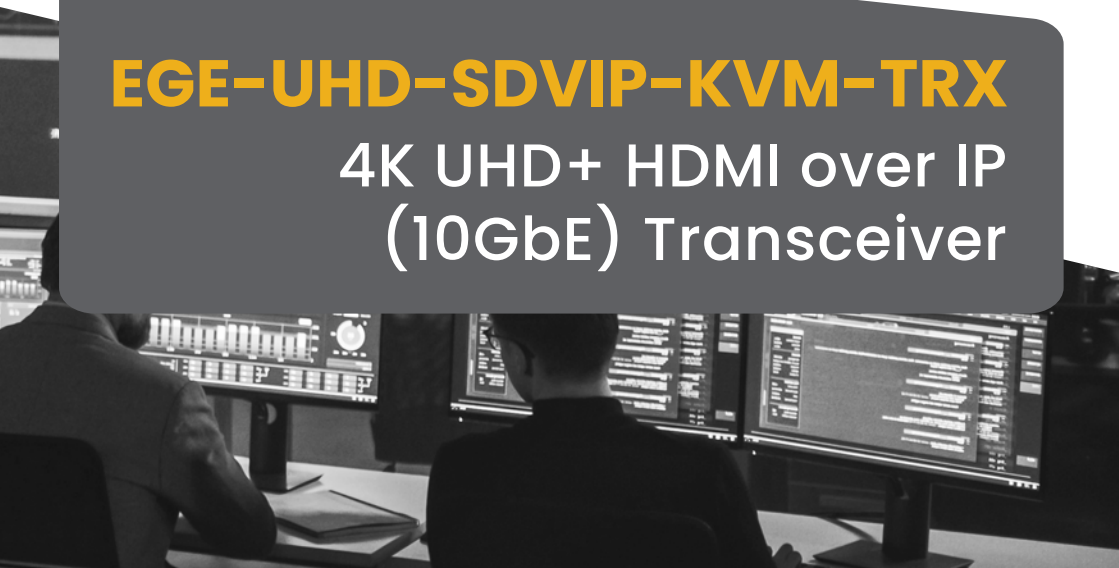

EGE-UHD-SDVIP-KVM-TRX

4K UHD+ HDMI over IP
(10GbE) Transceiver



DISCLAIMERS

The information in this manual has been carefully checked and is believed to be accurate. Geratech assumes no responsibility for any infringements of patents or other rights of third parties which may result from its use.

Geratech assumes no responsibility for any inaccuracies that may be contained in this document. Geratech also makes no commitment to update or to keep current the information contained in this document.

Geratech reserves the right to make improvements to this document and/or product at any time and without notice.

COPYRIGHT NOTICE

No part of this document may be reproduced, transmitted, transcribed, stored in a retrieval system, or any of its part translated into any language or computer le, in any form or by any means— electronic, mechanical, magnetic, optical, chemical, manual, or otherwise—without express written permission and consent from Geratech.

© Copyright 2018 by Geratech.

All Rights Reserved.

TRADEMARK ACKNOWLEDGMENTS

All products or service names mentioned in this document are trademarks of the companies with which they are associated.

SAFETY PRECAUTIONS

Please read all instructions before attempting to unpack, install or operate this equipment and before connecting the power supply. Please keep the following in mind as you unpack and install this equipment:

- Always follow basic safety precautions to reduce the risk of fire, electrical shock and injury to persons.
- To prevent fire or shock hazard, do not expose the unit to rain, moisture or install this product near water.
- Never spill liquid of any kind on or into this product.
- Never push an object of any kind into this product through any openings or empty slots in the unit, as you may damage parts inside the unit.
- Do not attach the power supply cabling to building surfaces.
- Use only the supplied power supply unit (PSU). Do not use the PSU if it is damaged.
- Do not allow anything to rest on the power cabling or allow any weight to be placed upon it or any person walk on it.
- To protect the unit from overheating, do not block any vents or openings in the unit housing that provide ventilation and allow for sufficient space for air to circulate around the unit.
- Please completely disconnect the power when the unit is not in use to avoid wasting electricity.

VERSION HISTORY

REV.	DATE	SUMMARY OF CHANGE
VS1	2018/11/06	Final technical review
VS2	2018/12/06	Updated Sections 6 (RS-232 Bypass), 8.1, 8.3
VS3	2018/12/20	Added Sections 6.3, 6.4, 6.5; updated Section 6.7, 8.2
VS4	2019/01/15	Fixed the product description

CONTENTS

1. Introduction	1
2. Applications	1
3. Package Contents	2
4. System Requirements	2
5. Features	2
6. Operation Controls and Functions	3
6.1 Front Panel	3
6.2 Rear Panel	4
6.3 IR Cable Pinouts	5
6.4 RS-232 Bypass Pinout	5
6.5 OSD Menu	6
6.6 Basic AV Extension	10
6.7 Advanced AV Extension	11
7. Connection Diagram	15
8. Specifications	16
8.1 Technical Specifications	16
8.2 Video Specifications	17
8.3 Audio Specifications	18
8.4 Cable Specifications	19
9. Acronyms	20

3. PACKAGE CONTENTS

- 1xHDMI over IP (10GbE) Transceiver • 1x12V/3A DC Power Adapter
- 1xPower Cord
- 1x3-pin Terminal Block to DE-9 (Male) Adapter Cable
- 1x3-pin Terminal Block to DE-9 (Female) Adapter Cable • 1xShockproof Feet (Set of 4)
- 1xOperation Manual

4. SYSTEM REQUIREMENTS

- HDMI source equipment such as a media player, video game console, PC, or set-top box.
- HDMI receiving equipment such as an HDTV, monitor, or audio amplifier.
- Analog audio receiving equipment such as headphones, an audio amplifier or powered speakers.
- A 10 Gigabit Ethernet network switch with jumbo frame and IGMP snooping support is required for distributed video systems. (Optional, required for multi-Tx/Rx systems)
- PC control software or control system hardware to configure distributed matrix, video wall or multi-view systems. (Optional)

5. FEATURES

- HDMI 2.0 and DVI 1.0 compatible
- HDCP 2.2 and HDCP 1.x compliant
- Can be configured to function as either a Transmitter or a Receiver
- 1 HDMI input
- 1 HDMI output (Functions as local monitor output in Transmitter Mode)
- 1 analog stereo jack (Functions as an input in Transmitter Mode and an output in Receiver Mode)
- IP switchable with minimum latency (requires optional control center/software)
- Ultra-light compression, lossless for most content
- Extension up to 100m in point-to-point mode (w/ Cat.6A cable)
- Independent breakaway A/V matrix switching (requires optional control center/software)
- Video wall generation (requires optional control center/software)
- Multi-view compositing (requires optional control center/software)
- Supports pass-through of 10/12-bit HDR sources (Point-to-Point and Genlock mode only)
- Supports pass-through of audio formats including LPCM 2.0/5.1/7.1,

Bitstream and HD Bitstream from HDMI sources

- Analog stereo audio extension, insertion and extraction (insertion and extraction requires optional control center/software)
- Bidirectional LAN, IR & RS-232 extension
- Unit can be powered directly by PoE when connected to a 10-Gigabit Ethernet (10GbE) switch that provides PoE (802.3af)
- Signal transmission interfaces with 10-Gigabit Ethernet switches via a single Cat.6A cable
- Basic configuration via front panel buttons with an On-Screen Display (OSD)
- Supports the use of an external control center or control software to provide expanded functionality (Contact your authorized dealer for more information!)

6. OPERATION CONTROLS AND FUNCTIONS

6.1 Front Panel

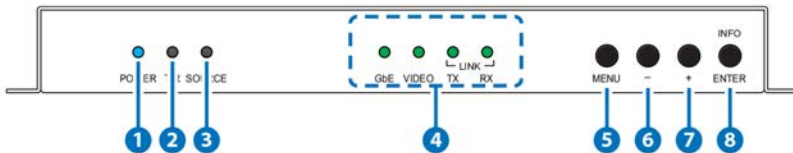

- 1 POWER LED:** This LED will illuminate to indicate the unit is on and receiving power.
- 2 T/R LED:** This LED indicates if the unit is in Transmitter (Green LED) or Receiver (Amber LED) mode.
- 3 SOURCE LED:** This LED will illuminate when the local HDMI input is live and selected.
- 4 STREAMING STATUS LED BLOCK:**
 - A GbE LED:** This LED will illuminate and blink to indicate a live and active connection on the gigabit Ethernet port.
 - B VIDEO LED:** This LED will illuminate when a video signal is live on the 10GbE streaming port. When no video is active the LED will remain off, even if the streaming connection is valid.
 - C TX & RX LINK LEDs:** These LEDs will illuminate and blink to indicate data transmission and reception activity across the 10GbE streaming connection.
- 5 MENU BUTTON:** Press to enter the OSD menu, or to back out from menu items.
- 6 – (MINUS) BUTTON:** Press to move down or adjust selections

within OSD menus. When not in a menu, press to manually toggle between inputs.

- 7 **+ (PLUS) BUTTON:** Press to move up or adjust selections within OSD menus. When not in a menu, press to manually toggle between inputs.
- 8 **ENTER/INFO BUTTON:** When inside an OSD menu, press to confirm a selection within the OSD or to go deeper into a menu item. When not in a menu, press to activate the Information OSD.

6.2 Rear Panel

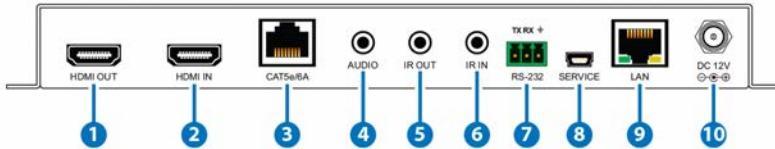

- 1 **HDMI OUT PORT:** Connect to an HDMI TV, monitor or amplifier for digital video and audio output.
- 2 **HDMI IN PORT:** Connect to HDMI source equipment such as a media player, game console or set-top box.
- 3 **CAT5e/6A PORT:** Connect directly to a compatible Transmitter/ Receiver, or to a 10 gigabit Ethernet switch, with a single Cat.5e/6/7 cable for transmission of all data signals.
Note: If the connected network switch supports the IEEE 802.3af PoE (Power over Ethernet) standard, this unit can optionally be powered directly via this Ethernet port.
- 4 **AUDIO PORT:**
 - A Transmitter Mode:** Connect to the stereo analog output of a device such as a CD player or PC. The audio signal is passed directly to the audio port on the connected Receiver.
 - B Receiver Mode:** Connect to powered speakers or an amplifier for stereo analog audio output. The audio signal comes directly from the audio port on the connected Transmitter.
- 5 **IR OUT PORT:** Connect to an IR Blaster to transmit IR signals to devices within direct line-of-sight of the IR Blaster.
- 6 **IR IN PORT:** Connect to an IR Extender to extend the IR control range of remotely located devices. Ensure that the remote being used is within direct line-of-sight of the IR Extender.
- 7 **RS-232 TERMINAL BLOCK:** Connect to a PC, laptop or other serial control device with a 3-pin adapter cable for the extension of RS-232 signals.

Note: Depending on the controlled device connected to the Receiver side, the Tx and Rx pins might need to be reversed.

- 8 **SERVICE PORT:** This port is reserved for rmware update use only.
- 9 **LAN PORT:** Connect to an Ethernet supporting device or to your local network as appropriate to extend the network between the Transmitter and Receiver.
- 10 **DC 12V PORT:** Plug the 12V DC power adapter into this port and connect it to an AC wall outlet for power (Optional, not required if the unit is powered via PoE).

6.3 IR Cable Pinouts

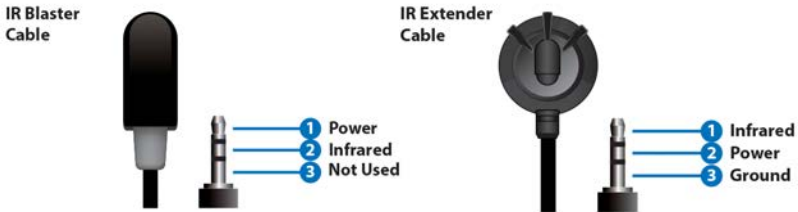

6.4 RS-232 Bypass Pinout

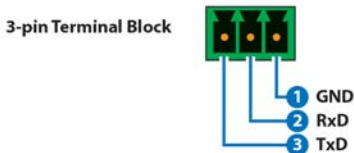

Serial Port Default Settings	
Baud Rate	57600
Data Bits	8
Parity Bits	None
Stop Bits	1
Flow Control	None

Note: The default Serial Port baud rate can only be changed by use of the optional control center or control software.

6.5 OSD Menu

Many functions of this unit can be controlled by using the OSD (On Screen Display) which is activated by pressing the Menu button on the front of the unit. Use the + (PLUS), - (MINUS), and ENTER buttons to navigate the OSD menu. Press the Menu button to back out from any menu item and then press it again to close the menu.

MAIN MENU
OSD
EDID
HDCP
Device Setting
Information
Factory Setting

The individual functions of the OSD will be introduced in the following section. Items marked in **BOLD** are the factory default settings.

OSD	
2ND LEVEL	3RD LEVEL
Display Information	ON
	Off
Display Information	Off
	10~40 Sec [10 Sec]
Menu Timeout	Off
	10~40 Sec [10 Sec]

- 1) **Display Information:** Enable or disable the Information OSD.
- 2) **Information Timeout:** Set the display timeout for the Information OSD.
- 3) **Menu Timeout:** Set the display timeout for the OSD Menu

EDID	
2ND LEVEL	3RD LEVEL
EDID Select	INTERNAL 1
	INTERNAL 2
	INTERNAL 3
	INTERNAL 4
	INTERNAL 5
	INTERNAL 6
	External A
	External B (Transmitter Mode only)
	User 1
	User 2

1) EDID Select: Select the EDID to send to the HDMI input. This unit provides the following 6 Internal EDIDs:

Internal 1	1920x1080p@60Hz (148MHz), 8-bit color	LPCM 2.0
Internal 2	1920x1080p@60Hz (148MHz), 8-bit color	LPCM 7.1 & Bitstream
Internal 3	3840x2160p@30Hz (297MHz), Deep Color (8/10/12-bit)	LPCM 2.0
Internal 4	3840x2160p@30Hz (297MHz), Deep Color (8/10/12-bit)	LPCM 7.1 & Bitstream
Internal 5	3840x2160p@60Hz (594MHz), Deep Color (8/10/12-bit)	LPCM 2.0
Internal 6	3840x2160p@60Hz (594MHz), Deep Color (8/10/12-bit)	LPCM 7.1 & Bitstream

Note: In some rare cases it is possible for custom or external EDIDs to cause compatibility issues with certain sources. If this happens, it is recommended to switch to one of the 6 default EDIDs for maximum compatibility.

HDCP	
2ND LEVEL	3RD LEVEL
HDMI HDCP	Follow In
	FOLLOW OUT
	Disable

1) HDMI HDCP: Set the HDCP behavior of the HDMI input.

- Follow In: The input supports up to the HDCP version required by the connected source.
- Follow Out: The input supports up to the HDCP version supported by the connected display.
- Disable: HDCP support is completely disabled.

DEVICE SETTING	
2ND LEVEL	3RD LEVEL
Status	TRANSMITTER
	Receiver
Fan Mode	FOLLOW TEMP
	Always On
Input (Receiver Mode only)	Input 1
	Input 2
Local Priority (Receiver mode only)	On
	OFF

1) Status: Set the operational mode of the Transceiver. After changing the operation mode, the unit will automatically reboot.

2) Fan Mode: Set the fan's activation behavior. Selecting "Follow temp" will result in the fan only turning on if the internal temperature becomes too high.

3) Input: Select the source to display on the HDMI output. Input 1 is the local HDMI input, Input 2 is the 10GbE streaming video input.

Note: Only available when the unit is in Receiver Mode.

4) Local Priority: Enable or disable the priority auto switch mode for the HDMI input. When enabled, the unit will automatically switch to the HDMI input if a live signal is present.

Note: Only available when the unit is in Receiver Mode.

INFORMATION	
2ND LEVEL	3RD LEVEL
Resolution	[Show the current status of each item]
Status	
FW Version	
IP	
MAC	
SN	
Fan Status	

1) Information: Shows details of the unit’s current status including detected input resolution, transceiver mode, firmware version, IP address, MAC address, serial number and fan state.

FACTORY SETTING	
2ND LEVEL	3RD LEVEL
Are you sure?	NO
	Yes

1) Factory Setting: Selecting YES will reset all of the unit’s settings back to their factory defaults.

6.6 Basic AV Extension

- Point-to-Point Configuration and Operation

The most basic extension configuration available is a point-to-point system with a single unit in Transmitter Mode connected directly to a single unit in Receiver Mode. In this configuration the HDMI input on the Transmitter is transmitted to the connected Receiver without modification to the audio or video format. The analog stereo audio port on the Transmitter functions as an input and transfers audio directly to the analog stereo audio port on the Receiver for output. The LAN, RS-232, and IR ports form direct connections between Transmitter and Receiver.



Note: This configuration does not use or require an external control center or software to function. No audio insertion/extraction is performed in this configuration. The default RS-232 bypass baud rate is 57600 and can only be changed by use of the optional control center or control software.

6.7 Advanced AV Extension

• Configuration & Control

When combined with the optional control center or control software, and a 10 gigabit Ethernet switch, this extension system gains a large number of additional configuration options including: multi-in/multi-out matrix switching with breakaway audio, video wall creation, and multi-view composite output. Analog audio extraction and embedding is fully controllable. Additionally, control over the configuration of the analog stereo audio ports becomes available, and the audio/IR/RS-232 routing can be fully controlled.

- Matrix Configuration

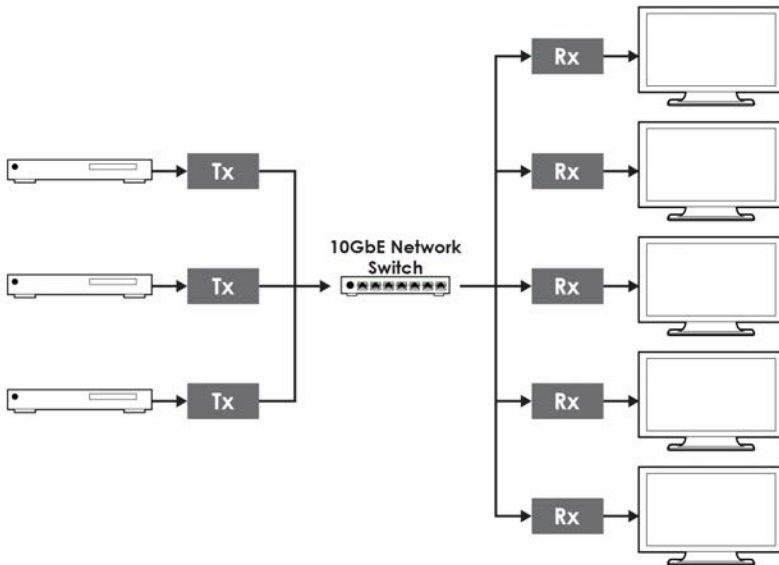

- Video Wall Configuration

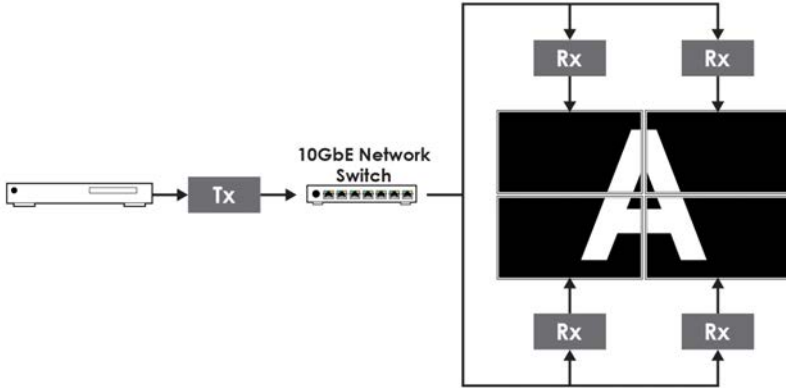

- Multi-View (PiP or Quad) Configuration

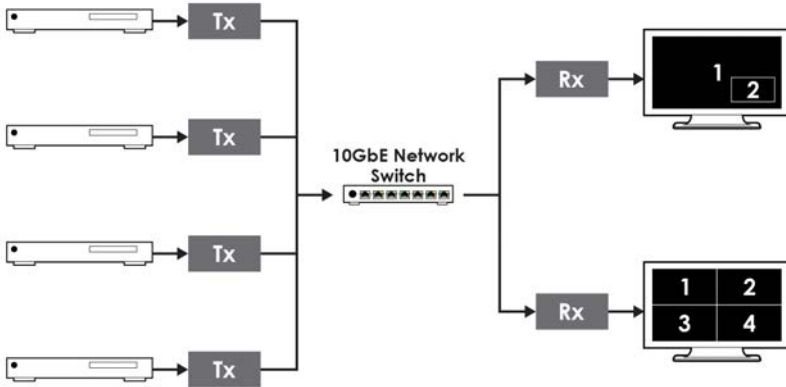

Note: The control center hardware/control software are optional components and are not included with the base unit. Please contact your authorized dealer for more information.

• Control Software

The control software is a fully software based solution for controlling multiple Transmitters and Receivers, in a variety of configurations, providing full and detailed control over the functionality of each individual unit. This software requires installation on a Windows 7 (SP1 or later), Windows 8, or Windows 10 PC/Laptop.



Note: Interface images are for example only and may differ from the delivered product.

• **Control Center Hardware**

The Control Center is a hardware solution designed to provide a unified and easy method to access and control all of the Transmitters and Receivers in a system. It provides a user-friendly, and operating system agnostic, web-based interface allowing easy control over all of the most critical functions within a distribution system.

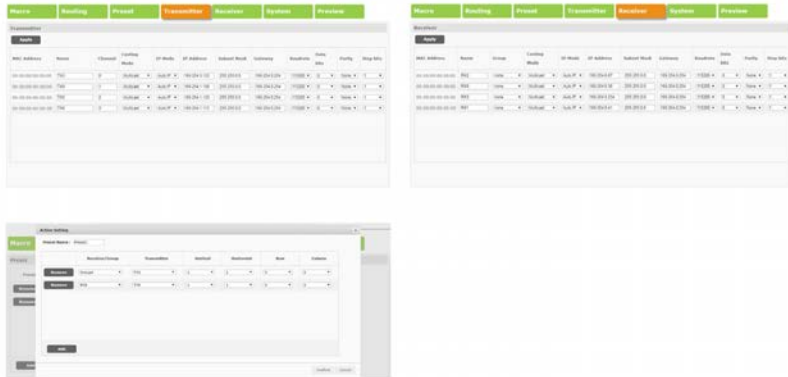

Note: Interface images are for example only and may differ from the delivered product..

7. CONNECTION DIAGRAM

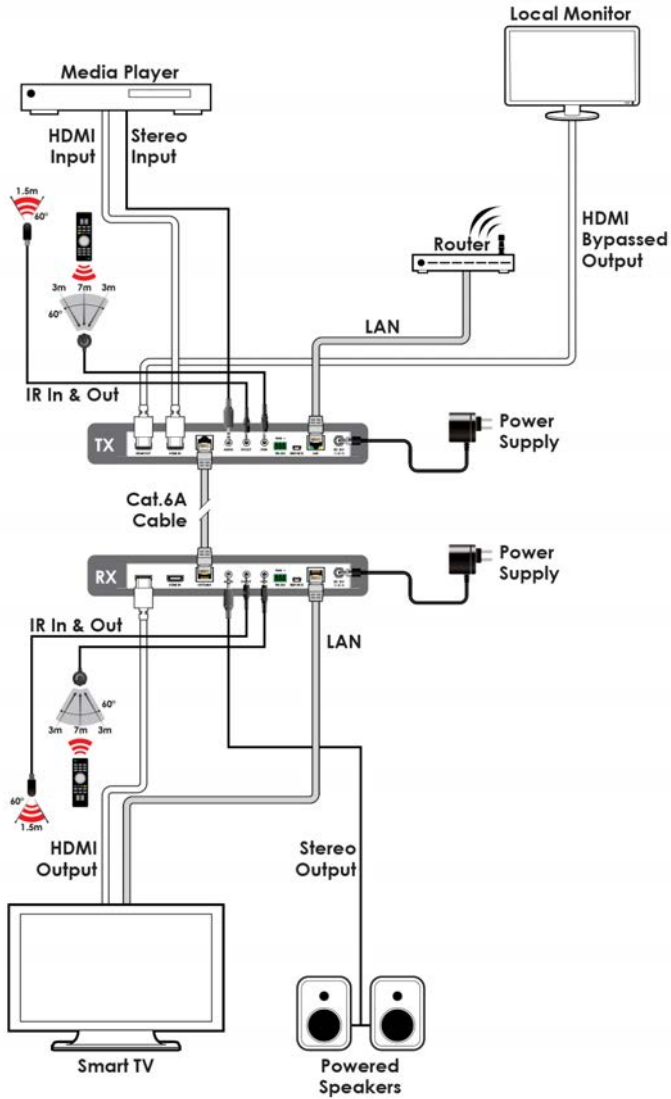

8. SPECIFICATIONS

8.1 Technical Specifications

HDMI Bandwidth	600MHz/18Gbps
Input Port	1×HDMI
Output Port	1×HDMI
Bidirectional Port	1×10GbE LAN (RJ-45)
Pass-through Ports	1×Analog Stereo (3.5mm) 1×IR Blaster (3.5mm) 1×IR Extender (3.5mm) 1×RS-232 (3-pin Terminal Block)
Control/Pass-through Port	1×LAN (RJ-45)
IR Frequency	30 – 50kHz (30 – 60kHz under ideal conditions)
Baud Rate	Up to 115200
Power Supply	12V/3A DC (US/EU standards, CE/FCC/UL certified)
ESD Protection	Human Body Model: ±8kV (Air Discharge) ±4kV (Contact Discharge)
Dimensions	231.5mm×25mm×108mm (W×H×D) [Case Only] 231.5mm×25mm×116.7mm (W×H×D) [All Inclusive]
Weight	552g
Chassis Material	Metal (Steel)
Silkscreen Color	Black
Operating Temperature	0 °C – 40 °C/32 °F – 104 °F
Storage Temperature	-20 °C – 60 °C/-4 °F – 140 °F
Relative Humidity	20 – 90% RH (Non-condensing)
Power Consumption	24.5W

8.2 Video Specifications

Supported Resolutions (Hz)	Input HDMI	Output HDMI	10GbE Cat.6a
720x400p@70/85	√	√	√
640x480p@60/72/75/85	√	√	√
720x480i@60	√	√	√
720x480p@60	√	√	√
720x576i@50	√	√	√
720x576p@50	√	√	√
800x600p@56/60/72/75/85	√	√	√
848x480p@60	√	√	√
1024x768p@60/70/75/85	√	√	√
1152x864p@75	√	√	√
1280x720p@50/60	√	√	√
1280x720p@50/60	√	√	√
1280x800p@60RB/60/75/85	√	√	√
1280x960p@60/85	√	√	√
1280x1024p@60/75/85	√	√	√
1360x768p@60	√	√	√
1366x768p@60RB/60	√	√	√
1400x1050p@60RB/60	√	√	√
1440x900p@60RB/60/75	√	√	√
1600x900p@60RB	√	√	√
1600x1200p@60	√	√	√
1680x1050p@60RB/60	√	√	√
1920x1080i@50/60	√	√	√
1920x1080p@24/25/30	√	√	√
1920x1080p@50/60	√	√	√

Supported Resolutions (Hz)	Input HDMI	Output HDMI	10GbE Cat.6a
1920x1200p@60RB	√	√	√
2560x1440p@60RB	√	√	√
2560x1600p@60RB	√	√	√
2048x1080p@24/25/30	√	√	√
2048x1080p@50/60	√	√	√
3840x2160p@24/25/30	√	√	√
3840x2160p@50/60 (4:2:0)	√	√	√
3840x2160p@24/25/30, HDR10	√	√	√
3840x2160p@50/60 (4:2:0), HDR10	√	√	√
3840x2160p@50/60	√	√	√
4096x2160p@24/25/30	√	√	√
4096x2160p@50/60 (4:2:0)	√	√	√
4096x2160p@24/25/30, HDR10	√	√	√
4096x2160p@50/60 (4:2:0), HDR10	√	√	√
4096x2160p@50/60	√	√	√

8.3 Audio Specifications

HDMI Input/Output	
LPCM	
Max Channels	8 Channels
Sampling Rate (kHz)	32, 44.1, 48
Bitstream	
Supported Formats	Standard & High-Definition

Analog Input	
Max Audio Level	1Vrms
Impedance	10kΩ
Type	Unbalanced

Analog Output	
Max Audio Level	1Vrms
THD+N	< -80dB@0dBFS 1kHz (A-wt)
SNR	> 80dB@0dBFS
Frequency Response	< ±1dB@20Hz~20kHz
Crosstalk	< -80dB@10kHz
Impedance	470Ω
Type	Unbalanced

8.4 Cable Specifications

Cable Length	1080p		4K30	4K60
	8-bit	12-bit	(4:4:4) 8-bit	(4:4:4) 8-bit
High Speed HDMI Cable				
HDMI Input	15m	10m	5m	3m
HDMI Output	15m	10m	5m	3m
Ethernet Cable				
Cat.5e	100m		70m	
Cat.6	100m		70m	
Cat.6A	100m			

9. ACRONYMS

ACRONYM	COMPLETE TERM
10GbE	10 Gigabit Ethernet
ASCII	American Standard Code for Information Interchange
Cat.5e	Enhanced Category 5 cable
Cat.6A	Augmented Category 6 cable
Cat.7	Category 7 cable
DHCP	Dynamic Host Configuration Protocol
DVI	Digital Visual Interface
EDID	Extended Display Identification Data
GbE	Gigabit Ethernet
HD	High-Definition
HDCP	High-bandwidth Digital Content Protection
HDMI	High-Definition Multimedia Interface
HDR	High Dynamic Range
HDTV	High-Definition Television
IP	Internet Protocol
IR	Infrared
LAN	Local Area Network
LED	Light-Emitting Diode
LPCM	Linear Pulse-Code Modulation
OSD	On-Screen Display
PoE	Power over Ethernet
SNR	Signal-to-Noise Ratio
THD+N	Total Harmonic Distortion plus Noise
UHD	Ultra-High-Definition
USB	Universal Serial Bus
WUXGA (RB)	Widescreen Ultra Extended Graphics Array (Reduced Blanking)



www.egerate.com

www.geratech.eu