

Rectangle Compression Jig / SQ-5030, 5075, 5150  
Disc Compression Jig / PC-5040, 5060, 5100  
Sphere Compression Jig / SP-5010, 5020, 5030

Variety of shapes and sizes for compression test

SP-5000 series



SQ-5000 series

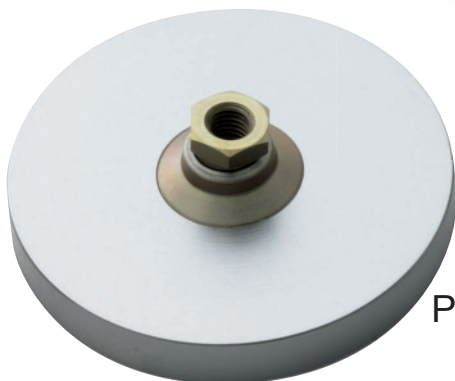
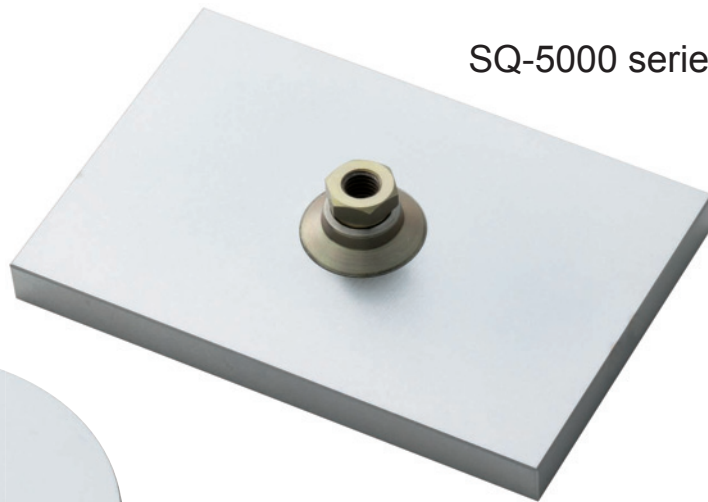

PC-5000 series

#### Feature

- Since a head can be shaken in the range of 15 degrees of front and rear, right and left, it can be adhered to a sample (SQ-5000 & PC5000 series).
- According to a usage, the compression tips of various form can be replaced by magnet adoption. (SQ-5000 & PC-5000 series).

**Applications**

- The compression test jigs are installed on the Imada's force gauge for compression test of various test pieces.

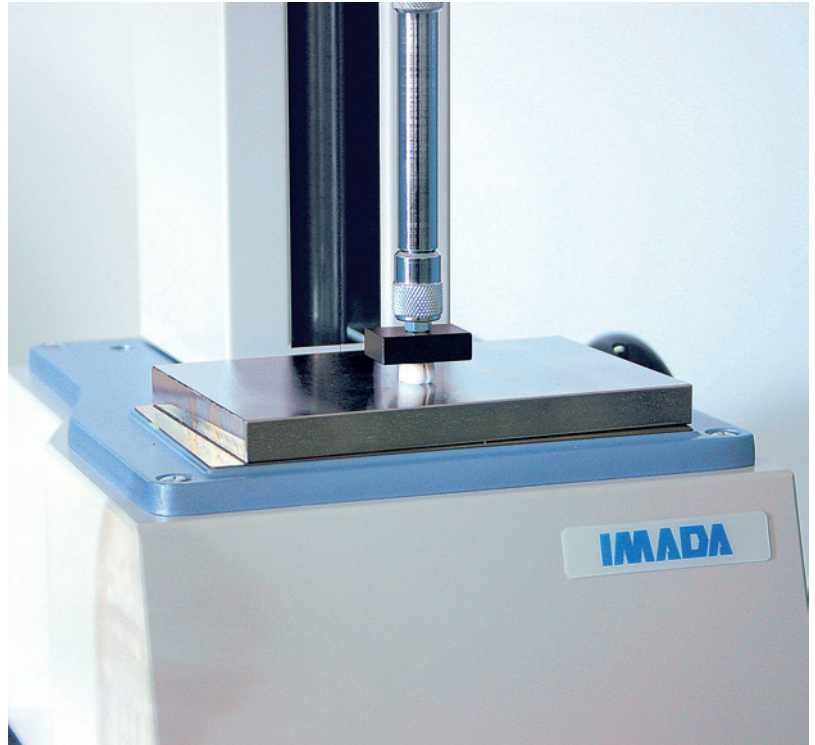

**Note**

- Particular materials and shape can not be used.
- Combining with a test stand, more stable measuring becomes possible.
- All information is subject to change without prior notice.

**Specifications**

Common

Capacity	5000 N
Mounting screws	M10

SQ series (square)

Model	SQ-5030	SQ-5075	SQ-5150
Board attachment part	M5 (Nut)	32 mm Ø (magnet)	
Measurement (LxW)	30 x 20 mm	75 x 50 mm	150 x 100 mm
Weight	70 g	500 g	1560 g

PC series (column)

Model	PC-5040	PC-5060	PC-5100
Board attachment part	32 mm Ø (magnet)		
Outer diameter (O)	40 mm Ø mm	60 mm Ø mm	100 mm Ø mm
Weight	160 g	330 g	820 g

SP series (sphere)

Model	SP-5010	SP-5020	SP-5030
Board attachment part	M5 (Nut)		
Diameter (D) Height (H)	10 mm 30 mm	20 mm 40 mm	30 mm 50 mm
Weight	30 g	60 g	140 g

## Dimensions

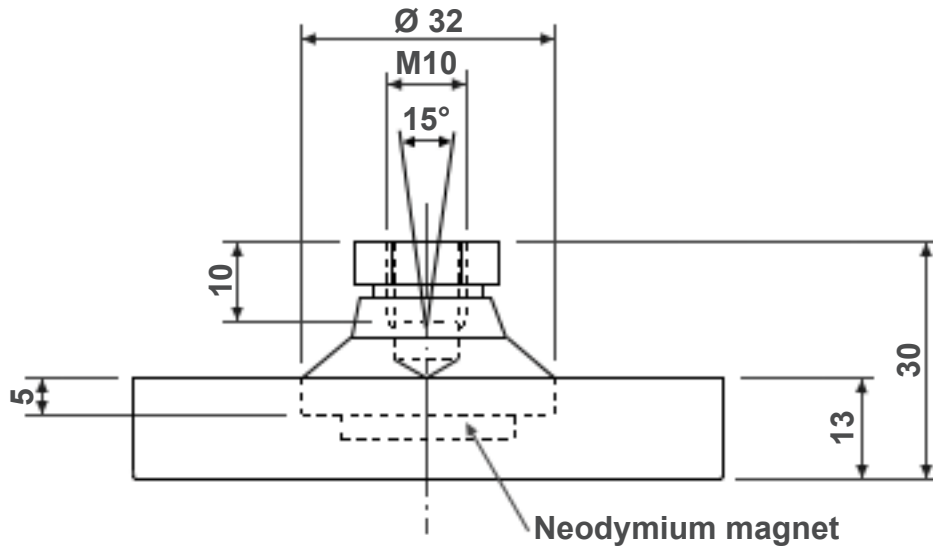

Series SQ

Series PC

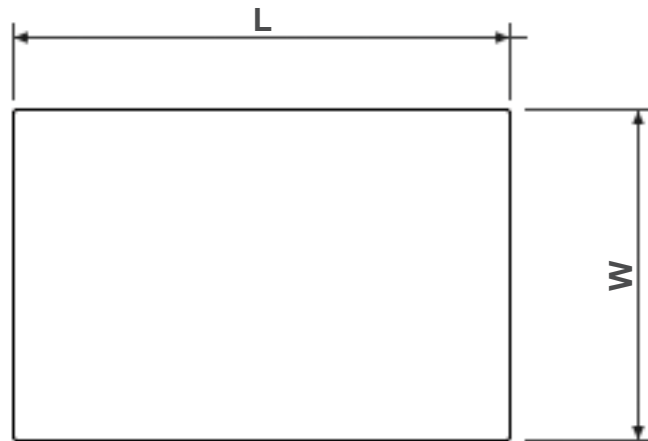
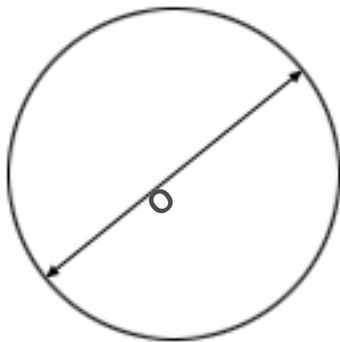

Series SP

