

Wire Wrapping Grips GC-30, WC-2000

For measuring the strength of wires

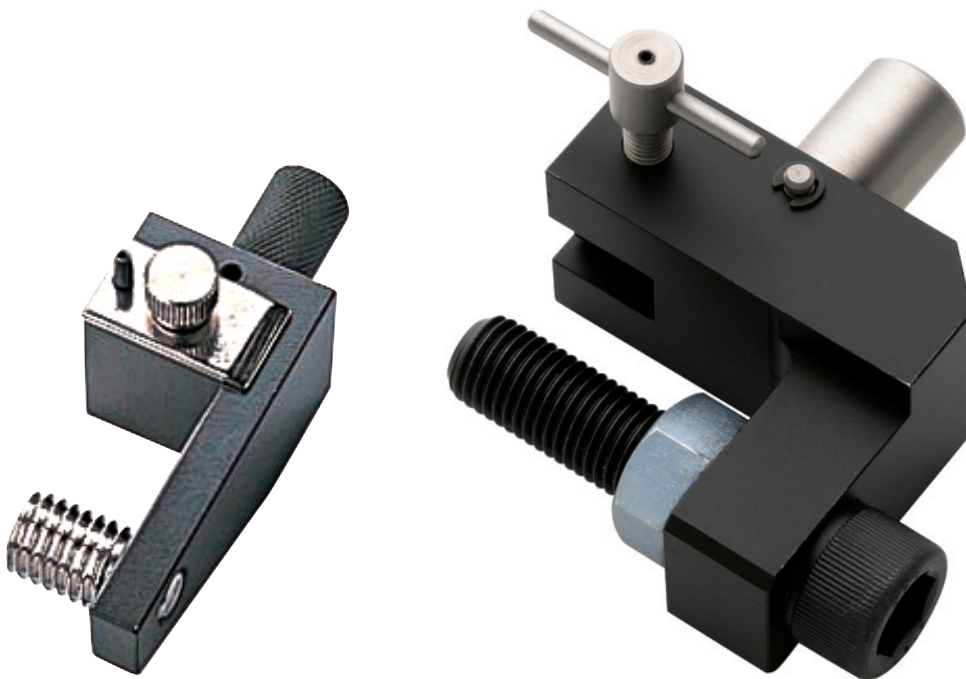

GC-30

WC-2000

Feature

- They are suitable for checking the strength of wires, filaments, fibers, etc.

Applications

- The wire wrapping grips are installed on force gauge for tension test of various test pieces.



Note

- Particular materials and shape can not be used.
- Combining with a test stand, more stable measuring becomes possible.
- All information is subject to change without prior notice.

Specifications

Model	GC-30	WC-2000
Type	normal	high capacity
Capacity	500 N (50 kgf)	2000 N (200 kgf)
Max. diameter of wire	1 mm	2 mm
Mounting screw (F)	M6	M10
Weight	136 g	900 g
Dimension (LxWxH)	28 x 36 x 77.5 mm	71 x 57 x 92 mm
Inside (A)	16.5 mm	42 mm
Height from bolt to grip (C)	33.0 mm	15 mm
Chuck height (D)	40.0 mm	65 mm
Diameter of wrapping bolt (E)	M10	M16
Recommended force gauge	PS/FB/DS2/ZTS/ZTA series 20 N - 500 N	PSH/ZTS/ZTA series up to 2000 N

Dimensional drawing

