

Attachment for pressure tests PR-500N, PR-2500N

Fixture for checking the durability of retorte pouches and heat seal packages

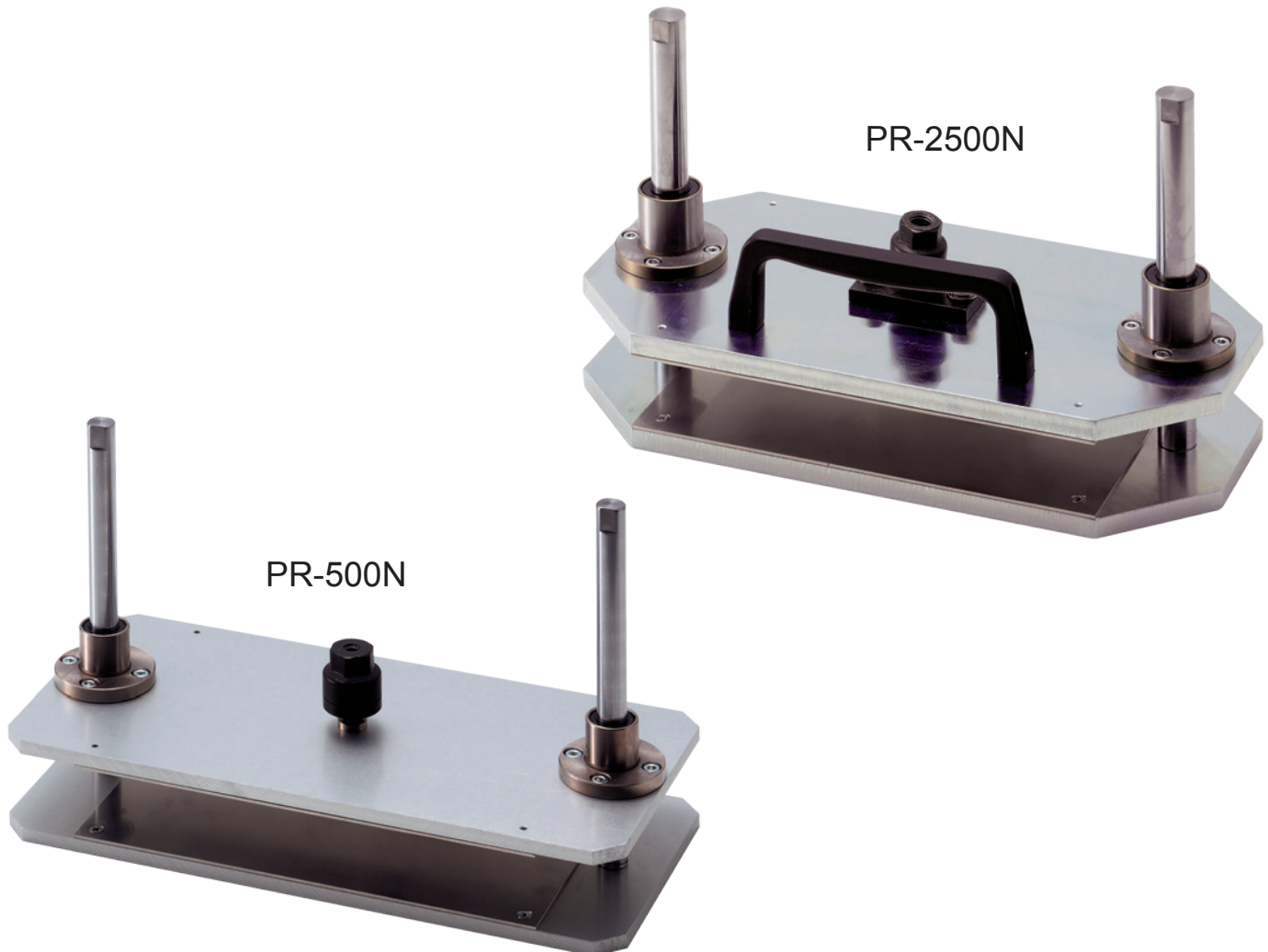

Features

- Convenient for checking the durability of retorte pouches and heat seal packages.
- For checking the tear strength of packages.
- In combination with the recommended components under specifications a constant force for a certain number of strokes or a certain time can be applied.
- Measurements according JIS Z0238 standard can be conducted in combination with the recommended components under specifications.

Applications

- Durability of retorte pouches and heat seal packages.



Specifications

Model	PR-500N	PR-2500N
Capacity	500 N	2500 N
Max. size of sample (WxDxH)	120 x 194 x 105 mm	140 x 200 x 105 mm
Weight upper part	aprox. 0.9 kg	aprox. 3.1 kg
Weight bottom part	aprox. 1 kg	aprox. 3.2 kg
Mounting screw for force gauge	M6	M10
Recommended components:		
Test stand	MX2-500N / MX2-1000N	MX2-2500N
Force gauge	ZTS-500N / ZTA-500N ZTS-1000N / ZTA-1000N	ZTS-2500N / ZTA-2500N ZTS-5000N / ZTA-5000N
Cable	CB-518	CB-518

The testing device is available with other dimensions than standard.
Therefor the modified dimension must be added to the type designation.
(H = Height, D = Depth, W = Width)

Ordering example for PR-2500N with a hight of 220 mm: **PR-2500N-H220**

Dimensional drawing

PR-500N

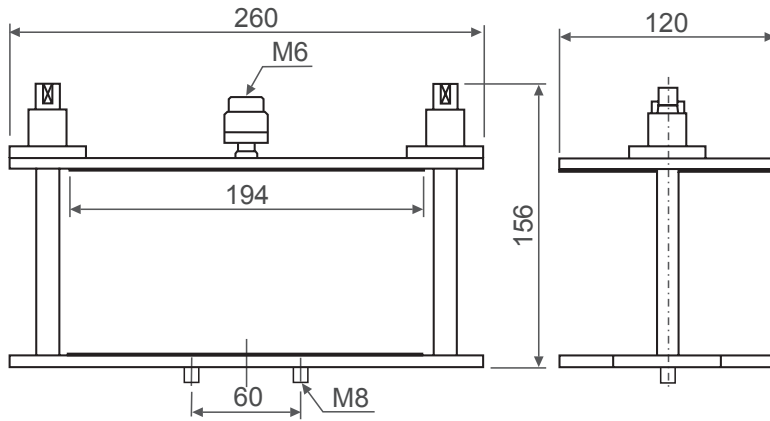

PR-2500N

