

## Table SJS-100N

For pull and shear tests on soldered  
electronic components

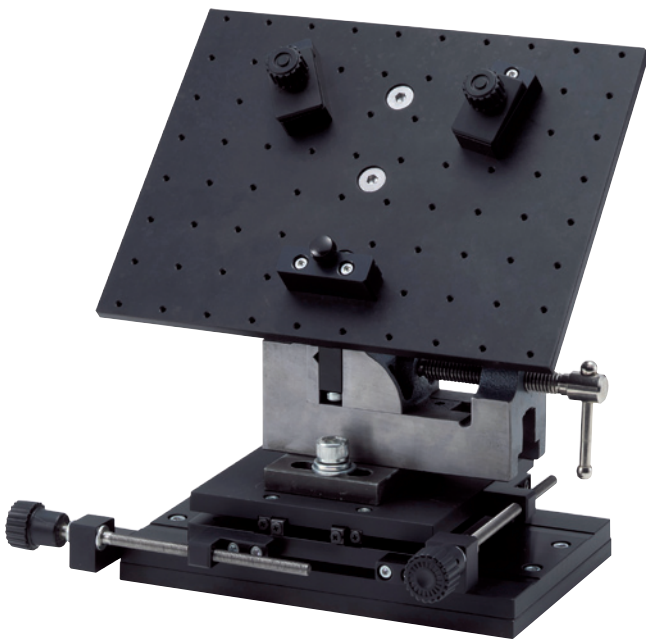

SJS-100N-L

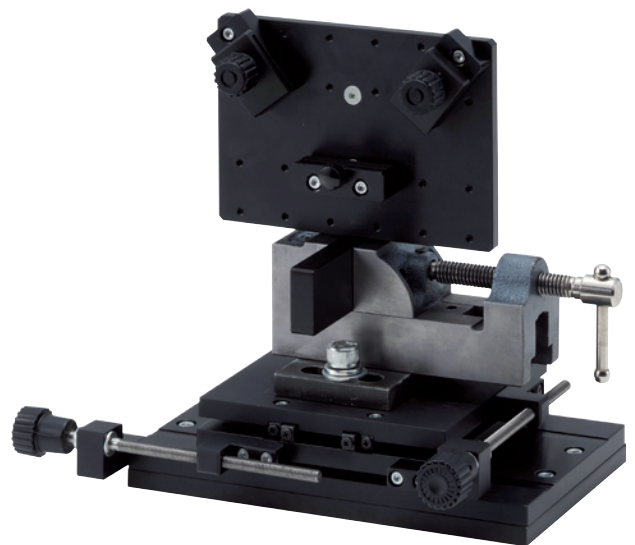

SJS-100N-S

### Feature

- The tables allow precise placement of the sample.
- Circuit boards can be mounted on the tables for testing the strength of solder joints.
- The table angle is adjustable between 45 and 90 degrees.
- Measurements according to different standards can be executed with hooks and pins of SJ series.

## Applications



### Note

- Combining with a test stand, more stable measuring becomes possible.
- All information is subject to change without prior notice.

## Specifications

Model	SJS-100N-L	SJS-100N-S
Application	large samples	small samples
Capacity	100 N	
Weight	approx. 3.2 kg	approx. 2.8 kg
Max. moving distance	$\pm 30$ mm	

## Dimensional drawing

SJS-100N-L

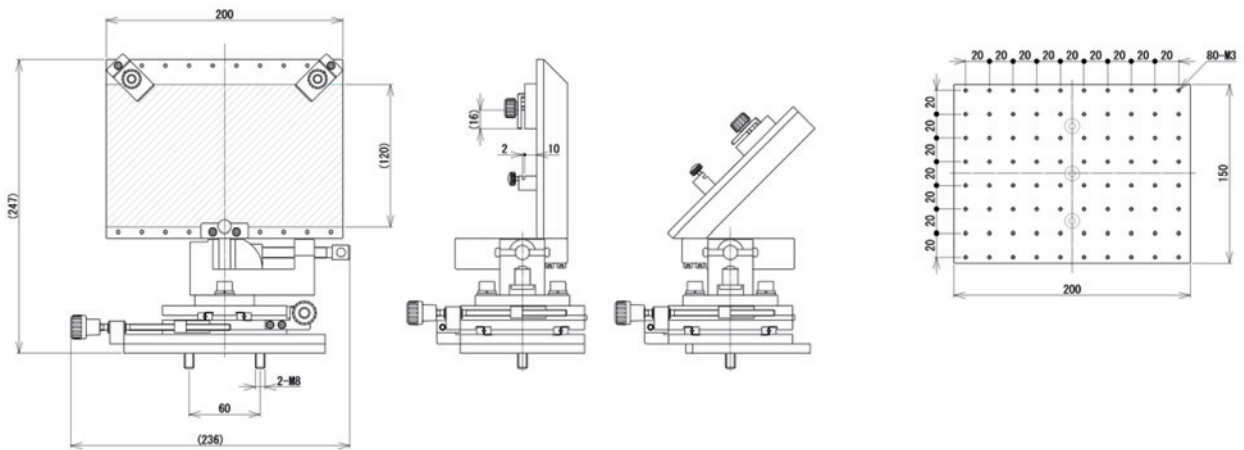

SJS-100N-S

