

Wire Winding Grips WG

For measuring the strength of wires

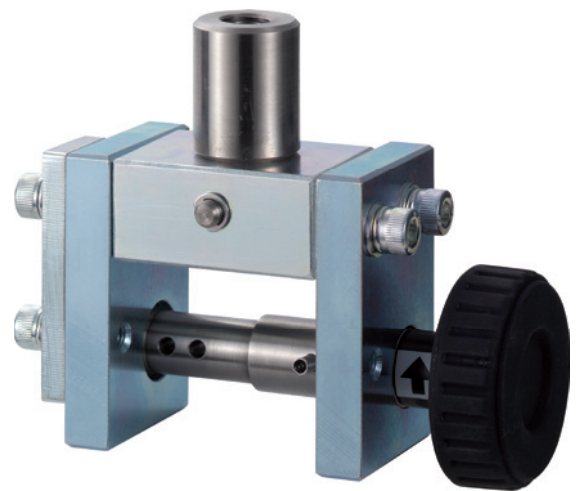

WG-250N



WG-5000N

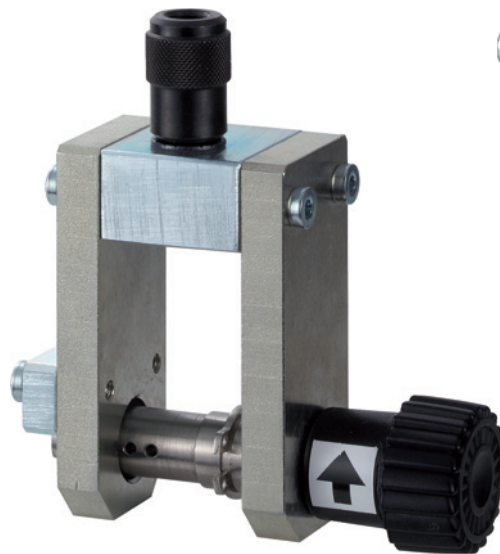

WG-1000N

Feature

- They are suitable for checking the strength of wires, fibers, etc.

Applications

- The wire winding grips are installed on force gauge or test stand for tension test with various materials



Note

- Particular materials and shape can not be used.
- Combining with a test stand, more stable measuring becomes possible.
- All information is subject to change without prior notice.

Specifications

| Model | WG-250N | WG-1000N | WG-5000N |
|----------------------|----------------|-----------------------------|---------------|
| Capacity | 250N | 1000 N | 5000 N |
| Method of winding | manuel by Hand | manuel by rotating the knob | |
| Diameter of bolt | 17 mm | 9 mm | 12 mm |
| Max. sample diameter | 1 mm | 1.2 mm | 3 mm |
| Min. sample length | 310 mm | 260 mm | 320 mm |
| Weight | approx. 60 g | approx. 180 g | approx. 610 g |
| Mounting screw | M6 | | M 10 |

Dimensional drawing

WG-250N

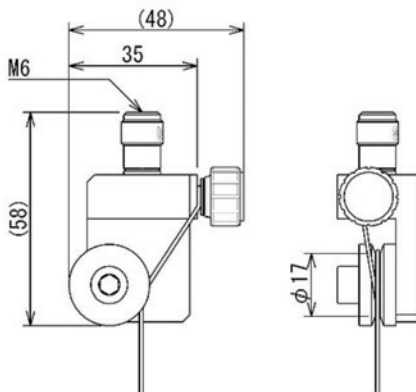

WG-1000N

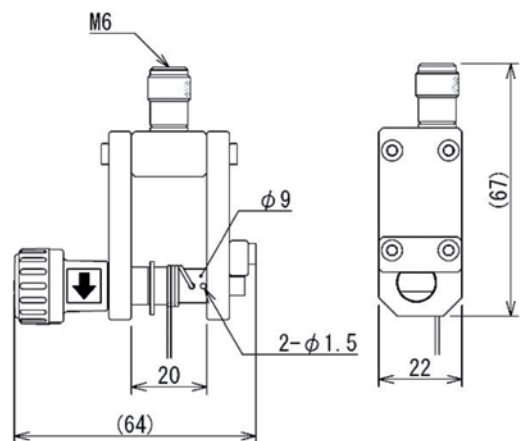

WG-5000N

