

## X-Y table - XY-500N series

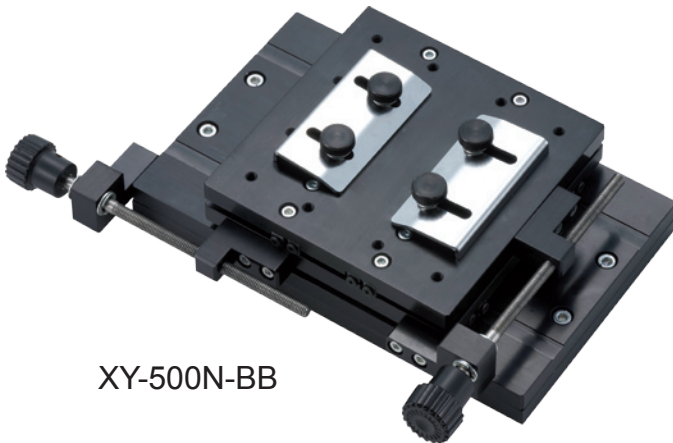

XY-500N-BB



XY-500N-EZ



XY-500N-M8

### Features

- The table can be precisely adjusted to the desired position with the adjusting knobs (XY-500N-BB und XY-500N-M8) or automatically aligns itself when force is applied (XY-500N-EZ).
- Low table secures stroke of vertical test stand.

## Applications

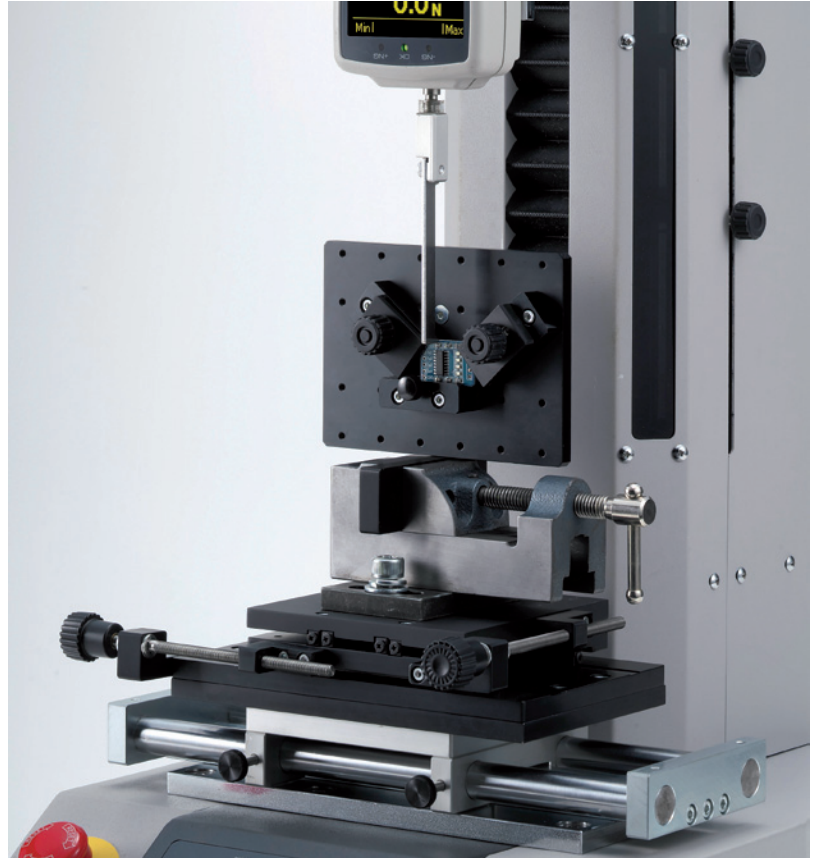
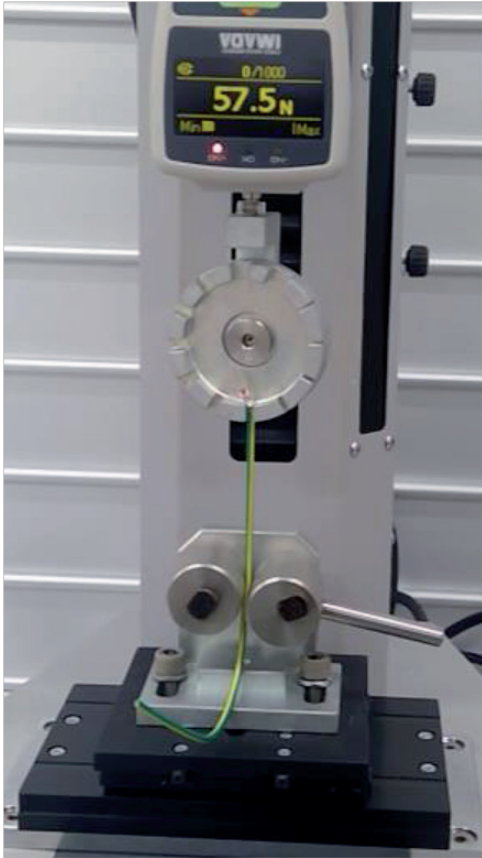

## Specifications

Model	XY-500N-BB	XY-500N-M8	XY-500N-EZ
Application	The sample is fixed on the table with the clamps.	A vice or adapter plate is mounted on the table, on which accessories can be mounted.	The specimen aligns automatically due to the freely movable stage. Only for tension tests
Capacity Compression Tension	1000 N 500 N	1000 N 500 N	- 500 N
displacement X-axis Y-axis	± 30 mm ± 30 mm		
Feeding methode	Adjusting knob (0.8 mm per turn)		free moveable
Mounting holes	M4	M8	M8
Weight	Approx. 1.5 kg	Approx. 1.5 kg	Approx. 1.4 kg

Dimensional drawing

XY-500N-BB

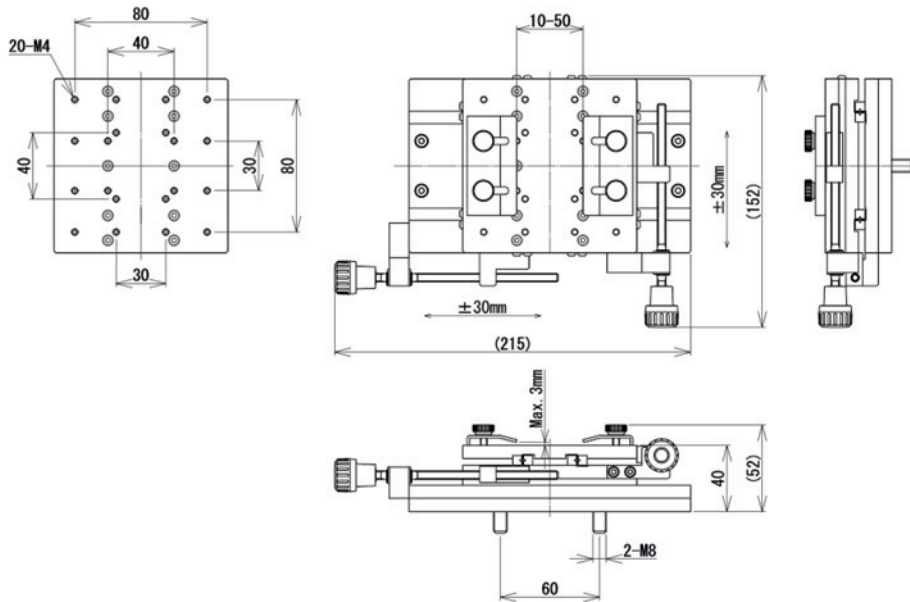

XY-500N-M8

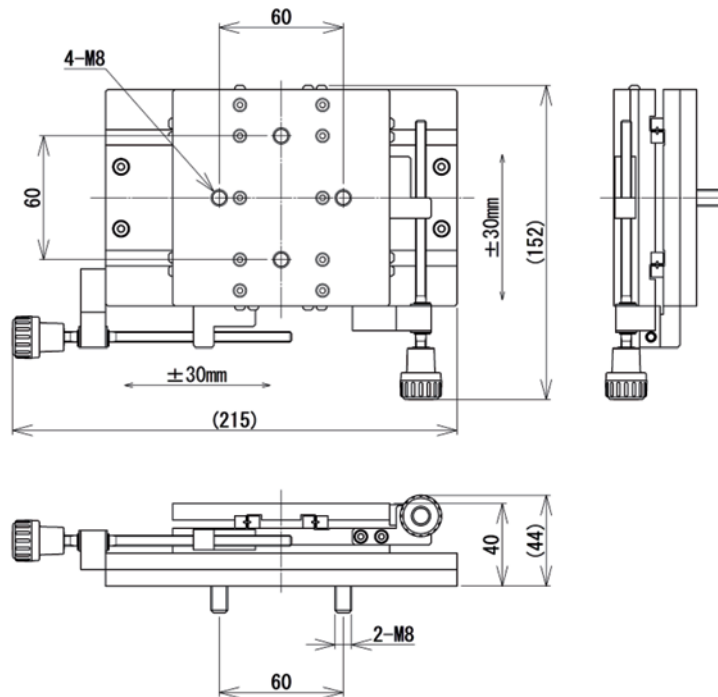

Dimensional drawing

XY-500N-EZ

