

Load Cell Model CHX / eCHX

CHX-100N/CHX-500N

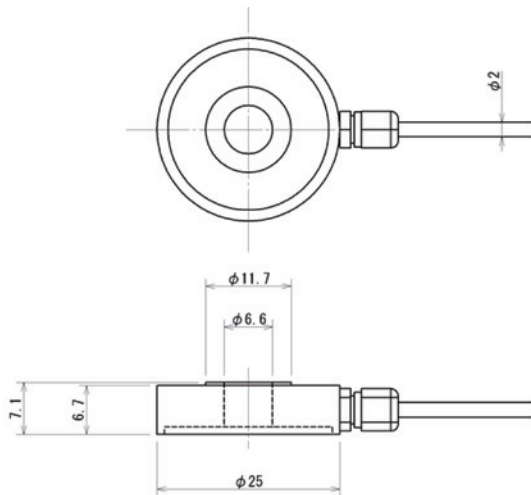

CHX-2000N

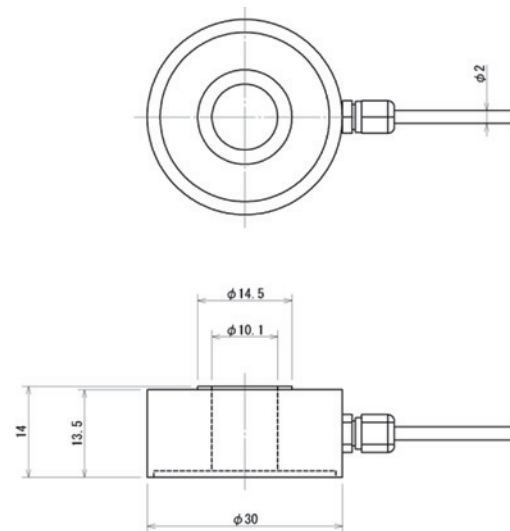

Amplifier ZTS/ZTA

| Model | Measuring Range | Dimensions Ø x H | Accuracy |
|-----------|-----------------|------------------|-------------------|
| CHX-100N | 100 N | 25 x 7.1 mm | ±2.0 % Full Scale |
| CHX-500N | 500 N | | |
| CHX-2000N | 2000 N | 30 x 14 mm | ±1.0 % Full Scale |

Amplifier eZT

| Model | Measuring Range | Dimensions Ø x H | Accuracy |
|------------|-----------------|------------------|-------------------|
| eCHX-100N | 100 N | 25 x 7.1 mm | ±2.2 % Full Scale |
| eCHX-500N | 500 N | | |
| eCHX-2000N | 2000 N | 30 x 14 mm | ±1.2 % Full Scale |