

Load Cell Model CLFX / eCLFX

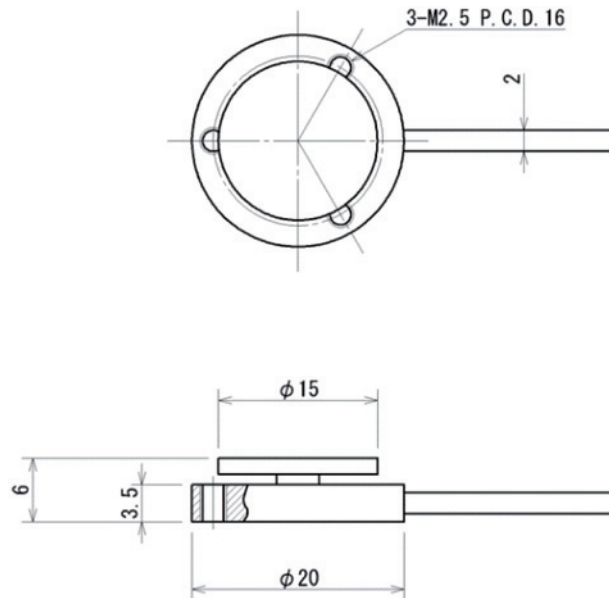

Amplifier ZTS/ZTA

Model	Measuring Range	Dimensions Ø x H	Accuracy
CLFX-50N	50 N	20 x 6 mm	±2.0 % Full Scale
CLFX-500N	500 N		

Amplifier eZT

Model	Measuring Range	Dimensions Ø x H	Accuracy
eCLFX-50N	50 N	20 x 6 mm	±2.2 % Full Scale
eCLFX-500N	500 N		