

Load Cell Model LC / eLC

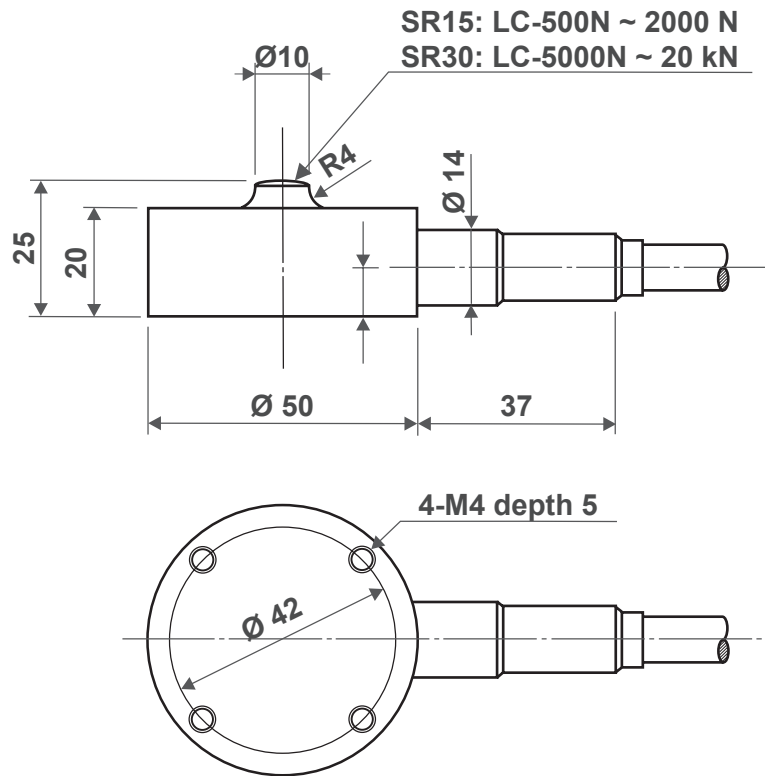

Model with Amplifier ZTS/ZTA*	Model with Amplifier eZT**	Measuring Range
LC-500N	eLC-500N	500 N
LC-1000N	eLC-1000N	1000 N
LC-2000N	eLC-2000N	2000 N
LC-5000N	eLC-5000N	5000 N
LC-10kN	eLC-10kN	10 kN
LC-20kN	eLC-20kN	20 kN

* Accuracy ± 0.5 % full scale

** Accuracy ± 0.7 % full scale