

## Load Cell Model SW1 / eSW1

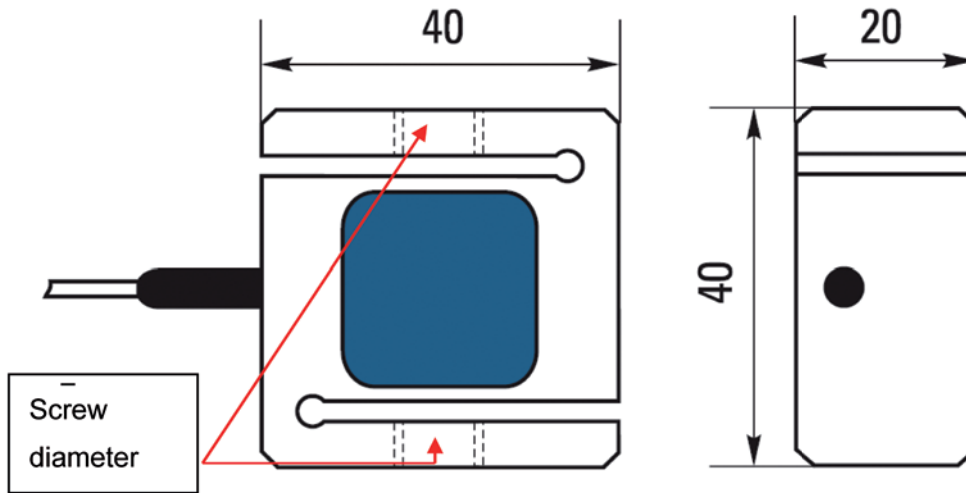

Model with Amplifier ZTS/ZTA*	Model with Amplifier eZT**	Measuring Range	Screw Diameter	Cable Length
SW1-100N	eSW1-100N	100 N	M6	spiral cable approx. 0.5 - 4 m
SW1-200N	eSW1-200N	200N	M6	
SW1-500N	eSW1-500N	500 N	M8	
SW1-1000N	eSW1-1000N	1000 N	M8	
SW1-2000N	eSW1-2000N	2000 N	M10	
SW1-5000N	eSW1-5000N	5000 N	M10	

\* Accuracy  $\pm 0.5$  % full scale

\*\* Accuracy  $\pm 0.7$  % full scale

# Load Cell Model SW3 / eSW3

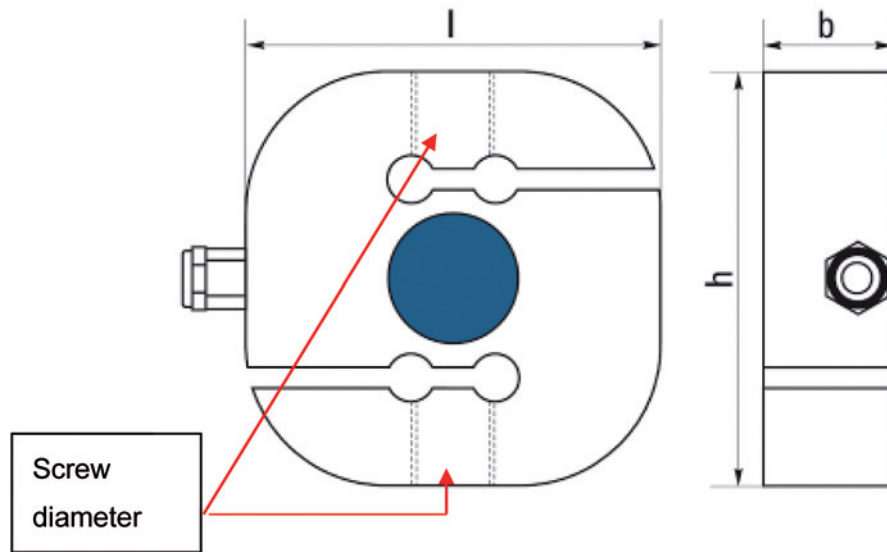

Model with Amplifier ZTS/ZTA*	Model with Amplifier eZT**	Measuring Range	l	b	h	Screw Diameter	Cable Length
SW3-10kN	eSW3-10kN	10 kN	80	25	80	M16	approx. 5 m
SW3-20kN	eSW3-20kN	20 kN					

\* Accuracy  $\pm 0.5$  % full scale

\*\* Accuracy  $\pm 0.7$  % full scale