

Stroboscope

SCHMIDT
control instruments



DSL Series

Model **DSL-300-LA**
DSL-300-LA-T (with trigger connection)

Operating Instructions



SCHMIDT · 1ST IN TENSIONMETERS WORLDWIDE

1. Complete overview of connections, controls and settings

- (A) ON / OFF
- (B) Menu
- (C) Laser / Confirmation button
- (D) MINUS
- (E) PLUS
- (F) DIV (Divider)
- (G) MUL (Multiplier)
- (H) Trigger connection



Figure 1: Stroboscope RT STROBE pocketLED LASER

- (1) Brightness in μ s and/or degrees (BRIGHT)
- (2) Delay in ms (DELAY)
- (3) Phase shift (PHASE)
- (4) Laser symbol
- (5) Unit of frequency in 1/min, Hz and/or FPM
- (6) Value
- (7) Mode (STROBO / TACHO)
- (8) Trigger divider (DIV.)
- (9) Slow motion (SLOW)
- (10) Trigger signal edge (TRIG.)
- (11) Internal / external trigger (INT / EXT)
- (12) Store / read parameter (MEMORY IN / MEMORY OUT)
- (13) Statistics (average / min / max)
- (14) Pro selection (P)
- (15) Battery status – full, half full

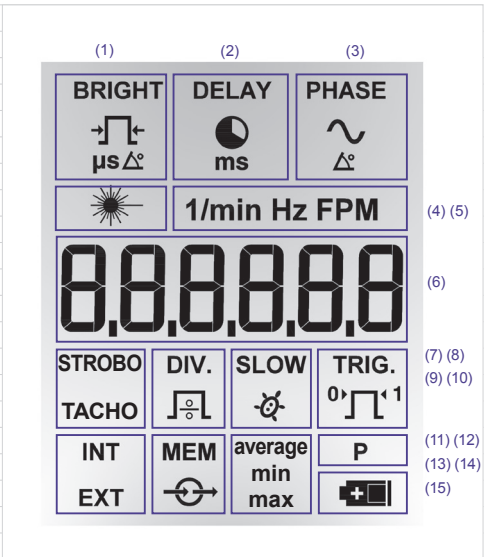

Figure 2: Display

Contents

1	Complete overview of connections, controls and settings	2
2	Technical data	4
3.	About these operating instructions	5
3.1	Conventional representation in this document	5
3.1.1	Presentation of work instructions	5
4	Intended use	5
5	Scope of delivery	5
6	Getting started	6
6.1	Brief description of set-up steps	6
6.2	Additional operating instructions for the version with trigger connection	6
7	Operation	6
7.1	Button assignment	6
7.2	Display	7
7.2.1	Overview of adjustable parameters	7
7.2.2	Standard selection	7
7.2.3	Pro selection	8
7.2.4	LASER in the TACHO and STROBO mode	9
7.2.4.1	Use of the laser	9
7.2.4.2	Auto-Sync function	9
7.2.4.3	Auto-Save function	9
7.2.5	Operation mode	10
7.3	Factory reset	10
8	Accessories, optional	11
9	Determining the actual rotational speed of an object	11

2. Technical data

General parameters	
Number of LEDs	6
Frequency range	30 ... 999.999 FPM (Flashes per minute)
Display	LCD, multiline, colored lighting
Accuracy	Flash frequency (internal) and frequency measurement (external): ± 0.02 % (± 1 digit / ± 0.025 µs)
Resolution	± 0.1 (30.0 ... 999.9 FPM) ± 1 (1,000 ... 999.999 FPM)
Current consumption	Max. 1.2 A
Flash parameters	
Light duration	0.025° ... 6.000° / 1 ... 1,000 µs
Light intensity	6,500 Lux @ 300 mm (12 inch) / 9,000 Lux @ 200 mm (8 inch)
Flash color	approx. 6,500 K (5,000 ... 8,000 K)
Illumination area	approx. 80 mm @ 300 mm approx. 3 inch @ 12 inch
Power supply	
Power supply	3 x AA size disposable batteries or 3 x NiMH rechargeable batteries
Continuous use time	5h @ 6,000 FPM
Housing	
Material	Aluminium / ABS, Heavy duty design
Dimensions (device)	191 x 82 x 60 mm
Dimensions (case)	207 x 252 x 72 mm
Weight (device)	approx. 400 g (including batteries)
Weight (total)	approx. 930 g (including case)
Ambient conditions	
Temperature	0 ... 45 °C / 32 ... 113 °F
Type of protection	IP65
Additional information for RT STROBE pocketLED LASER with trigger input and output.	
Trigger input	
Input signal level	Max. power: 3 ... 30 V Low level: < 2.0 V High level: > 3.0 V Pulse length: > 50 µs Switch: internal: 10 kOhm to + 24 V
Input current	10 kOhm to + 24 V
Trigger output	
Output signal level	Short-circuit and overvoltage proof transistor output, non-isolated NPN, < 1 V, max. 30 V
Output current capability	max. 50 mA
Sensor supply	24 VDC ± 15 % max. 60 mA

3. About these operating instructions

These operating instructions are an integral part of the device. They must be stored in an easily accessible location and passed on to subsequent users. Ask your supplier if there is something you do not understand.



Read the operating instructions thoroughly and follow the instructions provided. These operating instructions contain important information about installing, commissioning and operating the stroboscope. Pay particular attention to the safety information and warnings to prevent injuries and product damage.

The manufacturer reserves the right to develop and update the product continuously, without documenting all developments. Your supplier will be pleased to provide information on the status of existing operating instructions and on any alterations and extensions that may be relevant.

3.1 Conventional representation in this document

3.1.1 Presentation of work instructions

Work instructions are shown in numbered steps and must be carried out in the order stated.

- Step
→ An arrow is used to show stroboscope reactions to a step.
- Step
- Step

The end of a work instruction is shown as follows:

- End of work instruction

A work instruction that only consists of one single step will appear as follows:

- ▶ Step

4. Intended use

This device is used for inspecting the movement of rotating and vibrating objects (STROBO mode) and for non-contact measurement of rotational movements (TACHO mode). It may only be used in accordance with these instructions. The device must not be opened. Modifications to the device are not permitted. The manufacturer shall not be liable for damage resulting from incorrect use or use contrary to the intended use. Warranty claims will also be invalidated in this event.

⚠ Warning

Risk of injury!

Moving objects appear still or in slow motion in stroboscopic light. Do not touch such objects under any circumstance.

⚠ Warning

Risk of injury!

The device may not be used in potentially explosive areas.

⚠ Warning

Risk of injury!

Stroboscopic light can trigger epileptic seizures in persons at risk.

⚠ Warning

Risk of injury!

Never direct the LED beam at people or animals and do not stare directly at the beam.

⚠ Warning

Risk of injury!



Laser class 2

The stroboscope is fitted with a class 2 laser. This is located at the LED array of this device. The laser beam can damage eyes. For this reason, do not stare directly at the laser beam and never direct it at people or animals. Wavelength: 650 nm, output: 1 mW

⚠ Caution

Flashing lights can cause retina damage!



The stroboscope is fitted with 6 LEDs. These produce potentially dangerous optical radiation, which can cause retina damage. Do not stare directly at the light and never direct it at people or animals.

⚠ Caution

Warranty void!

The device may only be repaired by the manufacturer or by an authorized supplier.

⚠ Caution

Correct disposal!



The electronic components in the device contain environmentally harmful substances. They must be disposed of in accordance with the environmental regulations in the country of use.

△ Note

Suitable for use in residential, commercial and industrial area.

△ Note

Low risk (Risk group 1 – RG 1)

The brightness of the LEDs correspond to the risk group 1 according to DIN EN 62471:2009-03. The lamp resp. the light represents no hazard for the user under normal behavioral limitations.

5. Scope of delivery

Check that you have received all of the following:

- Stroboscope RT STROBE pocketLED LASER (device version with trigger / device version without trigger)
- Operating instructions
- Calibration certificate
- Cable with plug for trigger signal (device version with trigger)
- Reflective tapes
- 6 x AA size disposal batteries
- Case

6. Getting started

6.1 Brief description of set-up steps

Please follow the steps below when setting up the device:

1. Place 3 AA size batteries or NiMH rechargeable batteries into the device.
2. Direct the device at a moving object and switch on. Press the button "ON / OFF" (A) for at least 1 second.



The device will start to flash straightaway. For this reason, do not direct it at people or animals.

- The device will flash at the frequency that was set most recently. The display shows the selected flash frequency in the unit that was set most recently (1/min, Hz or FPM).
- If the flash frequency coincides with the frequency of the motion, a static image appears.
- If necessary, reset to factory setting by pressing and holding the buttons Menu "M" (B) and "MINUS" (D) simultaneously.

△ Note

Static images are produced when the flash frequency is identical to, or a multiple or fraction of the frequency of the motion (see also section 9 "Determining the actual rotational speed of an object").

6.2 Additional operating instructions for the version with trigger connection

⚠ Caution

Do not use signals over 999,999 FPM Hz to trigger the device.

△ Note

The device must be switched manually between external and internal trigger signal. Thus the 24 V sensor supply is switched on.

Terminal connection assignment trigger jack (Figure 3)

⚠ Caution

Please observe the terminal connections shown in the terminal connection diagram (figure 3).

The trigger input is suitable for NPN signals. A cable with plug, corresponding to these input jacks, is provided with the device. The trigger jack is located at the lower part in the center of the device.

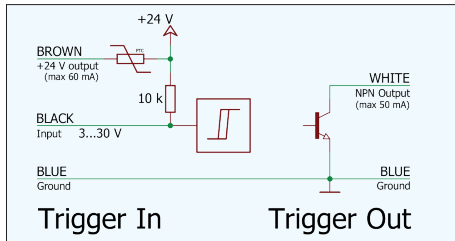

Figure 3: Terminal connection assignment

△ Note

The device must be manually switched between external and internal trigger signals (see section 7.2.2 "Standard selection" / How to select an internal / external trigger).

7. Operation

△ Note

Please note that this device comes in two versions.

Version 1: Stroboscope pocketLED LASER without trigger
Version 2: Stroboscope pocketLED LASER with trigger

Both versions are available in standard and pro modes (see sections 7.2.2 "Standard selection" and 7.2.3 "Pro selection").

7.1 Button assignment (Figure 1 on page 2)

No. Button	Description
(A) ON / OFF	- Switch on the device by pressing the button for at least 1 second.
(B) Menu	- Press this button to switch between the different settings and operation modes in the sequence of the display indicator (see figure 2).
(C) Laser	- Press this button to activate the laser. - The laser is activated and measures the frequency as long as the button is pressed. >> In the STROBO mode: The device flashes upon recognition of the reflective tape. >> The minimum, maximum and average values are determined (min, max, average). >> If the measured value remains within a tolerance of $\pm 5\%$ for 2 seconds, this value is taken over as a new flash frequency after releasing the button. - Momentarily press the button to activate. The laser remains activated until the button is pressed again. - This button can also be used to confirm selected settings.
(D) MINUS	- Decreases the currently selected value. >> Accelerates when this button is pressed. - Switch between the various settings.
(E) PLUS	- Increases the currently selected value. >> Accelerates when this button is pressed. - Switch between the various settings.
(F) DIV	- Halves the currently selected value. >> Accelerates when this button is pressed.
(G) MUL	- Doubles the currently selected value. >> Accelerates when this button is pressed.

△ Note

The symbol of a parameter that differs from the factory settings will flash during operation.

7.2 Display

△ Note

Preset values are retained in each mode (standard or pro selection)!

7.2.1 Overview of adjustable parameters

	Display	STROBO		TACHO	Device		Functions of button Menu "M" (B)	
		Standard	Pro		Without Trigger	With Trigger	Set value	Select parameter
Set frequency	1/min / Hz / FPM	•	•	•	•	•	•	
Select mode	STROBO / TACHO	•	•	•	•	•		•
Statistics	min / max / average	•	•	•	•	•		
Set brightness	BRIGHT deg	•	•		•	•	•	
Set phase shift	PHASE deg	•	•		•	•	•	
Select trigger	INT / EXT	•	•	•		•		•
Select frequency unit	1/min / Hz / FPM	•			•	•		•
Select brightness unit	BRIGHT deg / µs		•		•	•		•
Set delay	DELAY ms				•	•	•	
Set trigger divider	DIV.		•			•	•	
Set slow motion	SLOW		•			•	•	
Set trigger signal edge	TRIG.		•			•	•	•
Store parameter	MEM in				•	•	•	
Read parameter	MEM out		•		•	•	•	

△ Note

Backlight changes depending on selected mode.

STROBO mode: white

TACHO mode: orange



Laser mode: light-blue



When inactive, the backlight turns off automatically after approx. 10 seconds.





7.2.2 Standard selection (Figure 2 on page 2)

△ Note

Not all of the settings shown in figure 2 are available in standard selection.

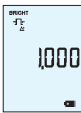
No.	Display	Adjustable parameters	Description
Off	-		Device is switched off.
(7) Display resp. setting the frequency			<p>Display resp. setting the frequency in 1/m, Hz or FPM.</p> <p>Change the frequency by pressing the buttons "PLUS" (E), "MINUS" (D), "DIV" (F) and/or "MUL" (G).</p>
How to set the frequency:			
1. Switch on the device by pressing the button "ON / OFF" (A) for at least 1 second.			
→ The following will then appear in the display for a few seconds			
<ul style="list-style-type: none"> • all settings followed by • "S", for standard selection 			
→ The following will then appear in the display:			
			
2. Set the desired frequency by pressing the buttons "PLUS" (E), "MINUS" (D), "DIV" (F) and/or "MUL" (G).			
<input checked="" type="checkbox"/> This setting is now active.			

No.	Display	Adjustable parameters	Description
(7) Mode		TACHO / STROBO	Selection of the mode: TACHO or STROBO
How to select the mode:			
1. Switch on the device by pressing the button "ON / OFF" (A) for at least 1 second.			
→ The following will then appear in the display for a few seconds			
<ul style="list-style-type: none"> • all settings followed by • "S", for standard selection 			
→ The following will then appear in the display:			
			
→ The following will appear in the display:			
			
→ The active parameter flashes			
2. Press the button Menu "M" (B) to switch between the different settings and operation modes in the sequence of the display indicator. Select the parameter you want to change (e.g. STROBO/TACHO).			
3. Switch between the parameters by pressing the buttons "MINUS" (D) or "PLUS" (E).			
4. Press the button menu "M" (B) again to move to the next parameter.			
<input checked="" type="checkbox"/> This setting is now active.			

No.	Display	Adjustable parameters	Description
(13) Statistics			The minimum, maximum and average values are consecutively displayed for 3 seconds each.
(1) Brightness		BRIGHT deg.: 0,025° ... 6,000°	Setting the brightness (in degrees).
<p>Brightness (BRIGHT in deg)</p> <p>Flash duration. This function allows the flash duration to be adjusted, which influences the brightness and focus of the object being viewed. In the standard mode, this setting can only be made in relative form (degrees), whereas the pro mode also features the additional setting of measuring brightness in absolute form (microseconds).</p>			
(3) Phase shift		PHASE deg.: 0 ... 359	Setting the delay between trigger signal and flash (in degrees; position of the flash is fixed, even though the frequency changes).
<p>Phase shift (PHASE in deg)</p> <p>Phase shift setting (in degrees, relative to the frequency) between the trigger signal and flash. This value allows a fixed angle to be set between the trigger signal and flash.</p> <ul style="list-style-type: none"> Example without external connection: The viewing position can be extremely precisely adjusted without changing the flash frequency. You can shift the viewing position within a movement cycle. Example with external connection: The external trigger signal is triggered before the desired observation point (= flash position of the stroboscope). This would mean that the connected stroboscope would regularly flash too early. The PHASE deg setting adjusts the delay, altering the flash position of the stroboscope by a set angle. This setting is not affected by the current rotational speed, which means that the stroboscope will flash at the desired position even during rotational speed fluctuations or during the start-up period. 			
(11) Trigger		INT / EXT	Selection of the trigger: Internal or external - This function is only available with the device version with trigger.
<p>How to select the trigger:</p> <ol style="list-style-type: none"> Switch on the device by pressing the button "ON / OFF" (A) for at least 1 second. Press the button Menu "M" (B) to switch between the different settings and operation modes in the sequence of the display indicator. Select the parameter INT / EXT. <p>→ The following will appear in the display:</p>  <p>→ The active parameter flashes</p> <ol style="list-style-type: none"> Switch between the parameters by pressing the buttons "MINUS" (D) or "PLUS" (E). Press the button menu "M" (B) again to move to the next parameter. <p><input checked="" type="checkbox"/> This setting is now active.</p>			

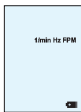
No.	Display	Adjustable parameters	Description
(5) Frequency unit		1/min / Hz / FPM	Selection of the frequency unit: - 1/min: Unit for measuring rotational speed - Hz: Flash frequency per second - FPM: Flashes per minute

7.2.3 Pro selection (Figure 2 on page 2)

▲ Note

Follow the steps below to access the pro mode:

► Switch on the device by pressing the button "ON / OFF" (A) and Menu "M" (B) simultaneously until the "Pro" notification appears in the display.



→ The following will then appear in the display: "Pro" for pro selection.



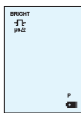

▲ Note

If pro mode is activated, a "P" will be shown in the bottom right area of the display.

▲ Note

If you have selected settings in pro selection and then switch the device off, these settings will ONLY be active when the device is switched back on if pro selection is activated. Otherwise, only the standard selection settings will be active.

No.	Display	Adjustable parameters	Description
Off	-		Device is switched off.
(1) Brightness		BRIGHT deg / μs	Selection of the brightness unit (in degrees or in microseconds). BRIGHT deg: 0,025° ... 6,000° BRIGHT μs: 1 ... 1,000 μs
<p>Brightness (BRIGHT in deg / BRIGHT in μs)</p> <p>Flash duration. This function allows the flash duration to be adjusted, which influences the brightness and focus of the object being viewed. Brightness can either be measured in absolute terms (microseconds) or in relative terms (degrees).</p>			
(2) Delay		DELAY ms: 0,0 ... 2,000	Setting the delay time (in milliseconds) between the trigger signal and flash (position of the flash changes with changing / fluctuating frequency).

No.	Display	Adjustable parameters	Description
(8) Trigger divider		DIV: 1 ... 65,535	Trigger divider, max. value 65,535. - This function is only possible when the external trigger is selected.
<p>Trigger divider (DIV)</p> <p>The trigger divider can be used to set a value x, by which the external trigger signal is then divided.</p> <p>Example: when scanning a cog wheel, an external trigger (e.g. rotational speed sensor) sends out a signal for each cog scanned. With a DIV value of 10, it will only flash once in every 10 signals.</p>			
(9) Slow motion		SLOW: 0 ... 600 FPM	- The flash frequency 0 ... 600 FPM exceeds the trigger by the value selected. - This function is only possible when the external trigger is selected.
<p>SLOW (slow motion)</p> <p>The "SLOW" function allows the viewer to view movement in slow motion. The speed of the slow motion depends on the flash frequency and corresponds to the value selected.</p>			
(10) Trigger signal edge		TRIG: 0 / 1	Setting the trigger signal edge (increasing: 0, decreasing: 1). - This function is only possible when the external trigger is selected.
(12) Store parameter		MEM IN: 1 ... 5	Selected parameters can be backed up in five separate storage locations. Set the desired storage location by pressing the buttons "PLUS" (E) or "MINUS" (D). - Confirm the setting by pressing the button "Laser" (C).
(12) Read parameter		MEM OUT: 1 ... 5	Stored parameters can be read out. - Set the desired storage location by pressing the buttons "PLUS" (E) or "MINUS" (D). - Confirm the setting by pressing the button "Laser" (C).

7.2.4 LASER in the TACHO and STROBO mode

⚠ Warning!
Risk of injury!!



Laser class 2

The stroboscope is fitted with a class 2 laser. This is located at the LED array of this device. The laser beam can damage eyes. For this reason, do not stare directly at the laser beam and never direct it at people or animals. Wavelength: 650 nm, output: 1 mW.

By means of a reflective laser beam, this stroboscope offers the possibility to determine the flash rate almost automatically and thus let moving parts appear optically "frozen". If you only want to measure the revolutions, you can also use the stroboscope as a laser tachometer with disabled flash function.

7.2.4.1 Use of the laser

The stroboscope features a laser in addition to the aforementioned settings (see sections 7.2.2 "Standard selection" and 7.2.3 "Pro selection"). To use the laser, you must first affix a reflective tape (included in the scope of delivery) onto the object to be measured.

Press the button "Laser" (C) to activate the laser and direct the stroboscope at the reflective tape onto the rotating object.

The laser beam will be reflected by this reflective tape back to the receiving cell on the front side of the stroboscope.

As a result, the control of the stroboscope calculates the rotation rate of the object.

7.2.4.2 Auto-Sync function

This function allows for the synchronisation frequency to be determined very quickly, without manual adjustment or external sensor signals. Furthermore, the additionally generated value guarantees absolute measuring certainty.

7.2.4.3 Auto-Save function

To enable the integrated "Auto-Save" feature, direct the stroboscope at the rotating object for at least 2 seconds. The measured frequency will be stored. After releasing the button "Laser" (C), the stroboscope flashes at this frequency and it can now be used for all other settings.



⚠ Note

The stroboscope function is disabled in the TACHO mode (LEDs off). In the TACHO mode, the backlight in the display changes to orange.

Momentarily press the button "Laser" (C) to activate. The laser remains activated until the button is pressed again.





⚠ Note

By activating the laser, the laser symbol appears in the display and the backlight changes to light-blue. When the reflective tape is detected at low speed, the laser symbol flashes briefly. At higher speed, it will flash continuously.

No.	Display	Adjustable parameters	Description
			The trigger frequency is 3,000 flashes per minute, determined by the reflective laser beam. The laser symbol flashes.
			The trigger frequency is below the measurement range.
			The trigger frequency is above the measurement range.

7.2.5 Operation mode

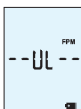
The following operation modes may be displayed:

No.	Display	Adjustable parameters	Description
Battery status			Battery fully charged.
Battery status			Battery half charged.
LASER / EXT			The trigger frequency is below the measurement range.
LASER / EXT			The trigger frequency is above the measurement range.

△ Note

When inactive, the backlight turns off automatically after approx. 10 seconds.

△ Note

The stroboscope will be automatically switched off after 15 minutes.

7.3 Factory reset

△ Note

To reset the factory settings, press and hold the buttons Menu "M" (B) and "MINUS" (D) simultaneously.

8. Accessories, optional

- Belt bag with clip
- Mounting kit for tripod or articulating arm
- Articulating arm including mounting kit
- Tripod, 3-way adjustable
- Recalibration
- Trigger cable

9. Determining the actual rotational speed of an object

The stroboscope can be used as a digital revolution indicator to determine an object's actual rotational speed and/or the frequency of cyclical movements. The stroboscope does this by visually "freezing" the object's movement and then taking a reading of the rotational speed or frequency from the LCD display. As is the case with all stroboscopes, it is vital to ensure that this "frozen" image is not a harmonic of the object's actual rotational speed.

Useful information:

- It's helpful to have a rough idea of the object's rotational speed beforehand.
- Regular shaped objects, e.g. a fan with several vanes or a motor shaft, must be affixed with an identification marking (using color or a reflective strip etc.) in order to be able to differentiate its orientation of movement.
- A still image always appears exactly at integer division of the speed of the object's actual rotational speed!

Example 1 (marking required):



This example shows the importance of using identification markings. Say you want to determine the actual rotational speed of this ventilator.

The only thing you know is that its rotational speed is less than 3,500 rpm. The following "frozen" images will appear if you reduce the flashing rate based on 3,500 FPM (flashes per minute):

Image no.	1	2	3	4
Flashing rate	3,300	2,200	1,650	1,320

Image no.	5	6	7	8
Flashing rate	1,100	825	733.3	550

What is the actual rotational speed of the fan? Images 1, 3, 5, 6 and 8 correspond to the original one, which means the rotational speed could be 3,300, 1,650, 1,100, 825 or 550 rpm.

Which is correct?



To determine the fan's actual rotational speed, one of the ventilator vanes is attached with a marking and the test is repeated.

Image no.	1	2	3	4
Flashing rate	3,300	2,200	1,650	1,320

Image no.	5	6	7	8
Flashing rate	1,100	825	733.3	550

The orientation marking confirms that the images at 3,300, 1,650 and 825 rpm are harmonic multiple images. Three identification marks appear in each of these images.

Still images appear at 1,100 rpm and again 550 rpm, each displaying just one mark. Remember that a still image always appears exactly at integer division of the speed of the actual rotational speed of an object. 550 is half of 1,100. This means that the rotational speed of the ventilator must be 1,100 rpm.

Example 2 (no marking required):

This example shows how the actual rotational speed of an object can be determined without using an orientation marking. This is only possible for suitably shaped objects.



Let's assume the only thing we know about this cam is that it rotates at less than 7,000 rpm. Its clear shape eliminates the need for an orientation marking. The following "frozen" images will appear if the flashing rate of 7,000 is reduced:

Image no.	1	2	3	4
Flashing rate	6,000	4,000	3,000	1,500

The images showing 6,000 and 4,000 rpm are double or multiple images rather than single images. Still images appear at 3,000 and again at 1,500 rpm. 1,500 is half of 3,000. This means that the actual rotational speed is 3,000 rpm.

Printed CE declaration of conformity is available on request.

Subject to technical changes without prior notification. Although the content of these instructions was compiled with the greatest care, we cannot accept liability for any errors.

SCHMIDT

control instruments

SCHMIDT-Test-Instruments
*indispensable in production monitoring,
quality control and automation*
We solve your measuring problems:



Tension Meter



Force Gauge



Torque Meter



Tachometer



Speed- and Lengthmeter



Electronic Lengthmeter



Stroboscope



Screen Printing Tension Meter



Thickness Gauge



Yarn Package Durometer and Shore-A Durometer



Sample Cutter



Balance



Moisture Meter



Leak Tester



Softometer

More than 70 years - Worldwide -

Hans Schmidt & Co GmbH

Mailing address:

P. O. B. 1154
84464 Waldkraiburg Germany

Shipping address:

Schichtstr. 16
84478 Waldkraiburg Germany

Phone:

int. + 49 / (0)8638 / 9410-0

Fax:

int. + 49 / (0)8638 / 4825

int. + 49 / (0)8638 / 67898

e-mail:

info@hans-schmidt.com

Internet:

<http://www.hans-schmidt.com>