

Force Gauge

SCHMIDT
control instruments



Edition FGP 01.E

FG Series

Model FGP

Operating Instructions

Valid as of: 01.10.2015 • Please keep the manual for future reference!



SCHMIDT · 1ST IN TENSIONMETERS WORLDWIDE

Safety Precaution

*Please keep this instruction manual at your side after you read.



Observe all warnings and cautions; it is extremely important and any safety serious contents are described.
Expression and meaning are as follows.



Warning

When you use FGP wrongly, it may cause serious problem, such as death or severe injury.



Caution

When you use FGP wrongly, it might cause serious problem depend on the situation.

Here are pictures which you have to follow.



It shows the reminder.



It shows the prohibition.



It shows the compulsion which you have to do.



Warning



Please be careful to the flying apart of the test substance.

At the breakdown test or break test, you might get injury due to the flying apart of the objects. Please wear the mask for the protection, and pay proper attention to safety.



Do not use scarred hook or deformed hook.

They might be broken or slip. Heavy test substance might hit your foot.



Caution



Do not load more than rated capacity.

Sensor may be broken. If you load further more, accident may happen because of the broken parts.



When "OVR" is displayed, it means overload. Please reduce the load immediately. Measuring value which is measured during the "OVR" is not correct.



Caution



Please use only supplied AC adapter for charging.

If you use non-supplied AC adapter, electronic circuit might be broken, and fire break might happen.



Do not charge and use the FGP other than AC 100 – 230V.

Become the source of fire disaster and electric shock.



Please plug the AC adapter in firmly.

When it is loose, short out and electric shock, and then it might be fire hazard.



Do not touch the AC adapter with wet hand.

There is the threat of electric shock.



Do not take down, repair, and make alterations to FGP.







You might be hurt because of the unusual operation.





Do not pull the code to unplug the AC adapter.

The code might be cut and short out, and then it might be fire hazard.

Safety precaution

 Caution	
 <p>Do not use AC plug covered with dust.</p> <p>It might the cause of the fire.</p>	 <p>Do not use and keep the FGP under the following circumstances.</p> <ul style="list-style-type: none"> · Location which will be gotten water · Location which receive direct sunlight · Dew condensation place · Dusty, salinity and iron content environments · Location which will be gotten oil and chemical · Corrosive and Flammable gas environment
 <p>When the FGP is dirty, please wipe with dry soft cloth, or please give the cloth soak in detergent which has mixed with water, then wring the cloth and wipe with it. Do not use a volatile chemical such as benzene, thinner, and alcohol.</p>	 <p>Please use the FGP in operating temperature in range 0°C~40°C .</p> <p>If you use FGP beyond above temperature, FGP might operate unusual.</p>
 <p>We recommend the force gauge to be checked and calibrated regularly. Though it is depend on the frequency of use and loading, the accuracy of measurement will be declined with time.</p>	 <p>Please operate the force gauge within operating humidity range; 35 ~ 85RH.</p> <p>If you use the force gauge beyond the above range, it might produce improper operation.</p>

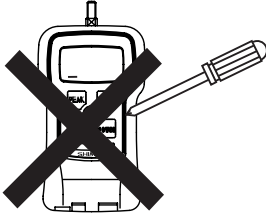
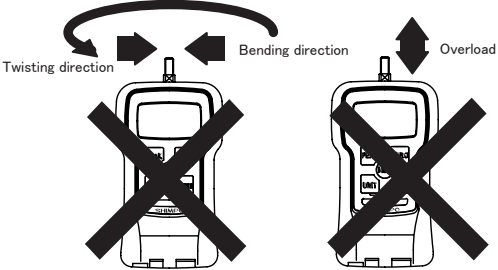
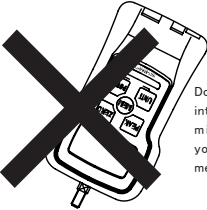
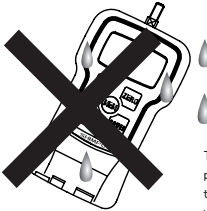
Caution before use.

 Caution	
<p>1. Do not press the button with a sharp-pointed object.</p> 	<p>2. Do not load bending direction or twisting direction.</p>  <p>FGP can measure pulling load and compression load. Do not load bending direction or twisting direction. Though FGP has a stopper which protects the sensor from careless operation, this stopper is helplessness for impact load, bending direction, and twisting direction.</p>
<p>3. Do not fall the force gauge.</p>  <p>Do not fall the force gauge into the ground. Sensor might be broken and you cannot get accurate measurement value.</p>	<p>4. Do not use the force gauge in location which will be gotten water.</p>  <p>This force gauge is not water proof. Please do not operate the force gauge in location which will be gotten water.</p>
<p>5. Measuring very small loading</p> <p>Tracking is ON at the factory default. When you measure small load, please turn the tracking OFF. (⇒ Please refer 4.4. Tracking)</p> 	

INDEX

<u>1.Product features</u>	4	5.6.Memory	14
<u>2.Confirmation of standard accessories</u>	4	5.6.1.Setting memory mode	16
<u>3.Part names and functions</u>	5	5.6.2.Storing data	17
3.1.Main unit	5	5.6.2.1.Store the data (Continuous memory mode)	17
3.2.Display	6	5.6.2.2.Store the data (Single memory mode)	17
3.2.1.Part names	6	5.6.2.3.Store the data (Standard memory mode)	17
3.2.2.Numeric display	6	5.7.Recalling memory data	18
3.2.3.Unit display	6	5.7.1. Continuous memory mode	18
3.2.4.Peak hold mode display	6	5.7.1.1.Measuring memory data	18
3.2.5.MAX/MIN display	6	5.7.1.2.Statistics memory data	19
<u>4.Before use</u>	7	5.7.2.Single memory mode	20
4.1.Charge	7	5.7.2.1.Measuring memory data	20
4.2.Attaching measuring adapter	7	5.7.2.2.Statistics memory data	21
4.3.Attaching hanger	7	5.7.3.Standard memory mode	22
4.4.Tracking	8	5.7.3.1.Measuring memory data	22
4.5.Function setting	8	5.7.3.2.Statistics memory data	23
4.5.1.Sign: f01	9	5.8.Erasing memory data	23
4.5.2.Display update time: f02	9	5.8.1.Erasing final memory data (one data)	23
4.5.3.Auto power off: f03	9	5.8.2.Erasing all memory data	24
4.5.4.Baud rate of RS232C: f04	10	5.8.3.No memory data	24
4.5.5.Measuring filter: f05	10	5.9.USB Communication	24
4.5.6.External output: f06	10	5.9.1.Feature of ToriemonUSB	24
4.5.7.Function mode=nd	10	5.9.2.Download ToriemonUSB	24
4.6.Reverse the display	11	5.9.3.Precaution when using USB communication	24
<u>5.Feature and Operation</u>	11	<u>6.External Connection Connector</u>	25
5.1.Overview of operation	11	6.1.Pin assignment	25
5.2.Measuring mode	12	6.2.RS232C output	25
5.2.1.Standard measuring mode	12	6.2.1.RS232C interface	25
5.2.2.Peak hold mode	12	6.2.2.RS232C communication command	26
5.3.Change display unit	12	6.2.3.Connection between FGP and PC	27
5.4.Tare	12	6.3.Analog output	27
5.5.Comparator	13	6.4.Overload/Comparator output	27
5.5.1.Comparator	13	<u>7.Frequently-asked questions</u>	28
5.5.2.How to enter Comparator/Memory setting mode	13	7.1.Questions for trouble	28
5.5.3.Setting HI limit	13	7.2.Questions for technical	28
5.5.4.Setting LO limit	14	<u>8.Support</u>	29
5.5.5.Jugement on LCD	14	8.1.Repair and Calibration	29
5.5.6.Output signal of judgement	14	8.2.Warranty	29
		<u>9.Specifications and Dimensions</u>	29
		Dimensions	30
		Force measuring attachments	30

1.Product Features

- Nickel –hydrogen battery enable us to use long time
→ 4.1. Charge
- Data can be downloaded to PC with USB
→ 5.9. USB communication
- Memorize up to 1000 data
→ 5.6. Memory
- Comparator enable us decision to pass or fail. (I/O output of the result)
→ 5.5. Comparator
- Rated Capacity 2.000N (200.0gf, 8oz) ~ 1000N (100.0kgf, 200lb)
→ 9 Specifications and Dimensions
- Reverse the display of the measuring value and the unit.
→ 4.6. Reverse the display
- One touch simple operation for changing the unit N, kg(g), Lb(oz).
→ 5.3. Change display unit
- Measure peak value at plus and minus side.
→ 5.2.2. Peak hold mode
- High-speed measuring (1000times/second)
→ 5.2.2. Peak hold mode
- Display update time is selectable up to 20 times/second.
→ 5.2.1 Standard measuring mode

2.Confirmation of Standard Accessories

- Before you use, please confirm the following items are included in the carrying case.

1. Main Unit



Check the model number

2. AC adapter

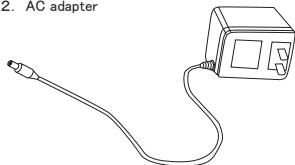

3. Instruction manual



4. Measuring adapters

M4 adapters are included in FGP-02 ~ 0.5. M6 adapters are included with other types.



Hook

M6
M4



Flat head

ϕ 12
 ϕ 8



Cone head

70°
60°



Notched head

70°
90°



Chisel

70°
60°

Extension rod L:92(M6)/L:86(M4)

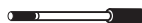

5. Hunger



6. USB cable (2.0 m)



3. Part names and functions

3.1.Main Unit

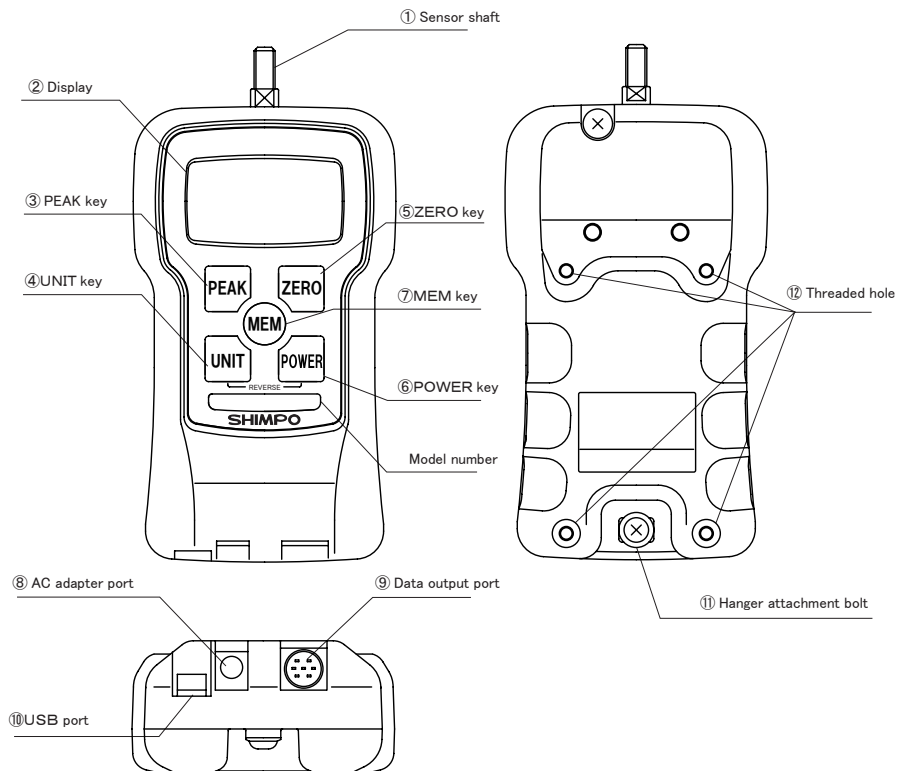

① Sensor shaft	Force bolt (Push/Pull Force)
② Display	Display the load and the unit.
③ PEAK key	<ul style="list-style-type: none"> • Switch standard measuring mode, + peak hold mode, or - peak hold mode. • Tracking ON/OFF. • It is used for comparator/memory setting.
④ UNIT key	<ul style="list-style-type: none"> • Switch the unit (N ⇒ Kg ⇒ lb(oz) ⇒ N) • It is used for reverse the display. • Tracking ON/OFF. • It is used for comparator/memory setting.
⑤ ZERO key	<ul style="list-style-type: none"> • Tare at standard measuring mode (not display a peak value). • It is used for function setting. • Press the ZERO key under the peak hold mode (display the peak value), clear the peak value. In this case, tare does not perform. If you need tare, press the peak key to change into standard measuring mode, then press the Zero key. • It is used for comparator/memory setting.
⑥ POWER key	<ul style="list-style-type: none"> • Press the POWER and release to turn ON/OFF. • It is used for reverse the display. • Tracking ON/OFF. • It is used for comparator/memory setting.
⑦ MEM key	<ul style="list-style-type: none"> • Press the MEM key under the standard measuring mode (not display peak value), then measuring value is memorized. • It is used to recall the memory data, and setting High/Low limits. • It is used for comparator/memory setting.
⑧ AC adapter port	Supply the electricity through the AC adapter.
⑨ Data output port	Connect with a PC and a recorder. (RS232C, analog output and so on)
⑩ USB port	Connect with a PC. (USB)
⑪ Hanger attachment bolt	Attach the hanger with this bolt.
⑫ Threaded hole	Use this threaded hole in order to attach the FGP with a stand.

3.2.Display

3.2.1.Part names

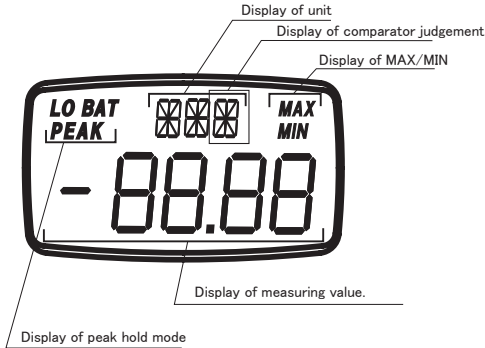

3.2.2.Numeric Display

Display the measuring value with sign and 4 digits numbers. Compression force: plus, Tension force: minus. (It's available to switch plus/minus with the setting of function (f01)).

Reverse display is available.

3.2.3.Unit Display

Display the units. In case of overload, "OVR" is shown. "PWR" appears to notify that there is 1 minute before power off.

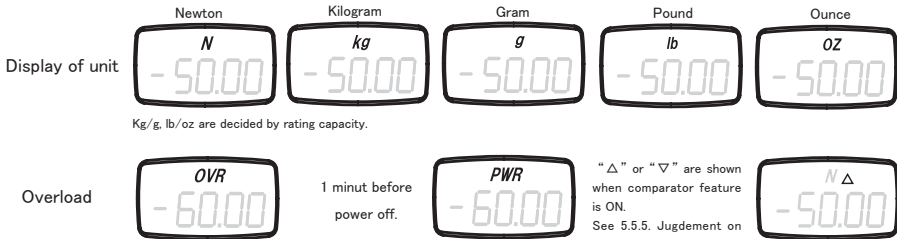

Reverse display is available.

3.2.4.Peak hold mode display

Depend on the condition of the force gauge, the following display is shown.



In case of the voltage of internal nickel hydride battery decrease, "LO BAT" has turned on and off. Please connect AC adapter to charge the battery.

During the charge of battery, "BAT" is shown. Even if turn the power off during the charge "BAT" has displayed.

"PEAK" has turned on when plus peak hold mode.*

"PEAK" has turned on when minus peak hold mode.*

* Please discern plus peak hold mode and minus peak hold mode with or without "-".

3.2.5.MAX/MIN display

In case of showing statistical data for memory mode (continuous, single, standard), the following display are shown.

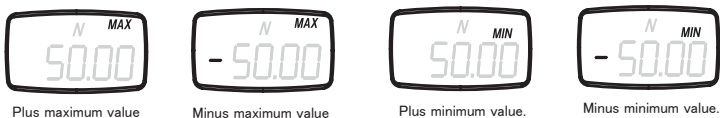

4. Before use

4.1. Charge



Do not charge with non-attached AC adapter.

Please use AC adapter which supplied with FGP. If you use non-attached AC adapter, electronic circuit might be broken and fire might happen.

Before the FGP arrive at your hand, nickel hydride battery might discharge electricity. Please plug attached AC adapter and charge before you use.

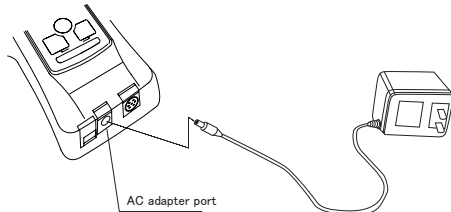

① Please connect the attached AC adapter into the AC adapter port of the body, and plug them into outlet.

- Start to charge the Nickel hydride battery. After the completion of the charge, it stops charging automatically by itself.
- "BAT" will be shown on the LCD display while charging. After complete the charging, "BAT" will be disappeared from LCD.
- Charge time: Up to 16 hours at most
- Operating time: Approx. 8 hours per 1 full charge

② The nickel hydride battery is charged automatically when it is discharged during the usage of AC adapter.

※ If you charge the battery frequently, its lifetime will be shorten. When you use the FGP with AC adapter, you should not insert and remove the AC adapter often.

③ You can measure during the charge.

④ When the voltage of nickel hydride battery decline, "LoBAT" has turned on in the LCD display. Please connect the AC adapter to charge. (If you leave the FGP with turned on "LoBAT", the voltage decline furthermore, and then the power is turned off compulsory.)

4.2. Attaching measuring adapter

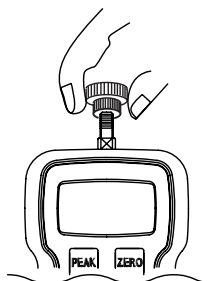

Please select the measuring adapter depend on the measuring purpose. Screw the adapter until it stops lightly. Do not screw it forcibly in order not to give the damage to the sensor.



Do not screw the attachment in forcibly.



Do not use bruised hook or deformed hook.

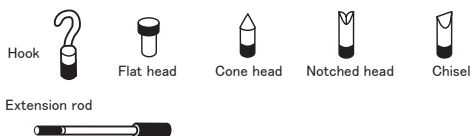

4.3. Attaching hanger

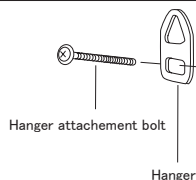

Please attached the hunger according to need.

Please use the hanger to hang the FGP with a nail or a winch.



※ Please use the tolerable nail or winch against the load.

Please take off the attached hanger bolt. Fit the square hole of hanger into the salient part of the case, and then tighten the attached hanger bolt.

4.4.Tracking

A load cell of strain gauge is used for FGP as a load sensing. By using this sensor, the measuring value is slightly changed due to temperature and so on, but tracking is able to cancel this slightly change by the software. When you measure very minute forces, measuring value error might happen due to the tracking. In this case, you may turn off the tracking function.

When the power off, while hold down the PEAK key and UNIT key simultaneously, press and release the POWER key (release the PEAK key and UNIT key after the value is appeared in the display more than 1 second), you can switch the tracking ON/OFF.

Key operation	Display
<p>Turn the power off</p> <p>① Hold down PEAK and UNIT key. ② Press POWER key.</p> <p>Release POWER key only.</p> <p>Please release the PEAK key and UNIT key after the value is appeared in the display more than 1 second.</p>	<p>Tracking ON</p> <p>Tracking OFF</p> <p>Standard measuring mode</p> <p>Tracking OFF</p> <p>Tracking ON</p> <p>Turn power off, then press POWER key, you can confirm the condition of the present tracking.</p>

4.5.Function setting



The following setting items in function mode.

Item	Unit	Set contents	Default factory setting
Display sign	f01	-0001(minus), 0001 (plus)	0001
Display update time	f02	1、 2、 3、 5、 10、 20 (times/second)	3
Auto power off	f03	10 (10 minutes)、 oFF (not valid)	10
RS-232C baud rate	f04	2400、 4800、 9600、 19200 (bps)	2400
Measuring filter	f05	3、 20、 150 (msec)	3
External output	f06	ovEr、 Hi-Lo	ovEr

Key operation	Display
<p>Turn the power off</p> <p>① Hold down ZERO key. ② Press POWER key.</p> <p>Release POWER key only.</p> <p>Please release the ZERO key after the value is appeared in the display more than 1 second.</p>	<p>Display force gauge model</p> <p>Display function mode (f01)</p>

4.5.1. Sign: f01

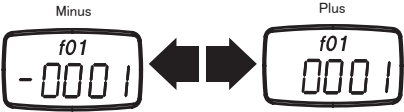

It's available to set the sign (plus or minus) of measuring value for pushing the sensor shaft.
Select the sign by use of UNIT key / Press the PEAK key to move ahead.

Key operation	Display
 Each time to press UNIT	
	Register the all setting, and then move to the standard measuring mode.
	Reserve the change, and then move to f02.

4.5.2. Display update time: f02

It's available to set the display update time for 1 time/second, 2 times/second, 3 times/second, 5 times/second, 10 times/second and 20 times/second. After the setting, the averaging value in display update time is shown every display update time.

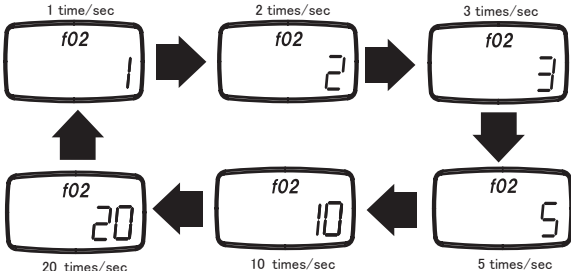



Press the UNIT key to choose the display update time (1、2、3、5、10、20 (times/second)) / Press the PEAK key to move ahead

Key operation	Display
 Each time to press UNIT	
	Register the all setting, and then move to the standard measuring mode.
	Reserve the change, and then move to f03.

4.5.3. Auto power off: f03

If the gauge is on and there is no activity for 10 minutes*, the unit automatically powers off to conserve battery charge (In case of connected with AC adapter, Auto power off function does not work). "PWR" appears to notify that there is 1 minute before power off. Press the UNIT key to switch the auto power off / Press the PEAK key to move ahead



* There is no key operation, RS-232C communication, USB communication, change of measuring value.

Key operation	Display
 Each time to press UNIT	
	Register the all setting, and then move to the standard measuring mode.
	Reserve the change, and then move to f04.

4.5.4. Baud rate of RS-232C : f04

It's available to set the baud rate of RS-232C.

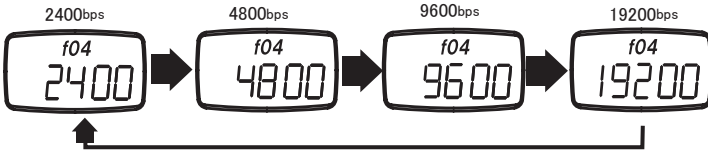

Press the UNIT key to switch the Baud rate (2400、4800、9600、19200(bps)) / Press PEAK key to move ahead.

Key operation	Display
 Each time to press UNIT	
	Register the all setting, and then move to the standard measuring mode.
	Reserve the change, and then move to f05.

4.5.5. Measuring filter : f05

It's available to set 3 types of filters as follows.

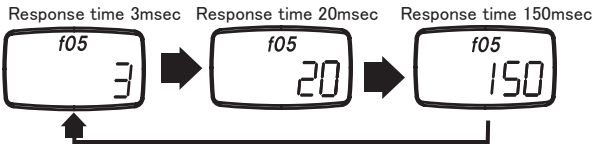
Press UNIT key to switch (response time 3 (msec)、20 (msec)、150 (msec)) ※Press PEAK key to move ahead

Key operation	Display
 Each time to press UNIT	
	Register the all setting, and then move to the standard measuring mode.
	Reserve the change, and then move to f06.

※ Filter response time show 90% of step input.
 Depend on the filter response, sampling period and analog output update period is decided.

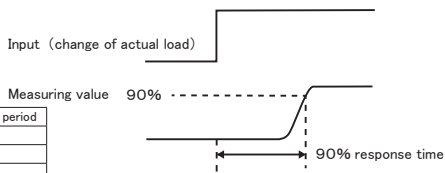

Filter response	Sampling period · Analog output update period
3msec	1msec
20msec	1msec
150msec	6.7msec



4.5.6. External output : f06

It's available to chose external output (overload output or comparator output).

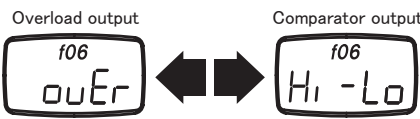
Press UNIT key to switch external output. / Press PEAK key to move f01.

Key operation	Display
 Each time to press UNIT	
	Register the all setting, and then move to the standard measuring mode.
	Reserve the change, and then move to f01.

※ When you set "ovEr", both the display of comparator judgement and I/O output are not performed.







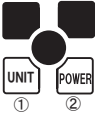

4.5.7. Function mode—end

Press ZERO key to memorize the set value and come back from function mode to standard measuring mode.

In order to cancel the change of function mode, press POWER key, then turn the POWER off.

4.6.Reverse the display

In the case you attach FGP with a stand, display of the value and the units can be reversed in order to read the display easily. Turn POWER off. Press the UNIT key and hold, then press POWER key and release (release UNIT key after the value is appeared in the display more than 1 second). Then you can reverse the display.

Key operation	Display
<p>Turn the power off</p>  <p>① Hold down UNIT key ② Press POWER key.</p>  <p>Release POWER key only.</p> <p>Please release the UNIT key after the value is appeared in the display more than 1 second.</p>	<p>Standard display</p>  <p>Reverse display</p>  <p>Standard measuring mode</p>  <p>Display force gauge model</p> <p>Reverse display</p>  <p>Standard display</p>  <p>Standard measuring mode</p> 

5.Feature and Operation

5.1.Overview of operation

1) Basic operation

Key	Operation
POWER	Turn the POWER ON/OFF
ZERO	Tare (Peak reset at the PEAK Hold mode)
PEAK	Standard measuring mode / Plus peak hold mode / Minus peak hold mode
UNIT	Change the unit
MEM	Store the measuring data into memory

2) Special operation

Key	Operation	How to operate
PEAK + UNIT POWER	Tracking ON / OFF	Turn POWER off. Press PEAK key and UNIT key simultaneously and hold, then press and release POWER key (release the PEAK key and UNIT key after the value is appeared in the display more than 1 second.)
ZERO POWER	Function mode	Turn POWER off. Press ZERO key and hold, then press POWER key and release (release ZERO key after the value is appeared in the display more than 1 second). Function mode; UNIT : Change the setting content PEAK : Switch the function ZERO : Register the setting content
UNIT POWER	Reverse display	Turn POWER off. Press UNIT key and hold, then press POWER key and release (release the UNIT key after the value is appeared in the display more than 1 second.)
MEM POWER	Display memory data	Turn POWER off. Press MEM key and hold, then press POWER key and release (release MEM key after the value is appeared in the display more than 1 second). Display memory data; UNIT : Display the statistical data. PEAK : Memory data display end. ZERO : Delete one memory data. Hold ZERO key to delete all data MEM : Next memory data
PEAK POWER	Comparator memory mode setting	Turn POWER off. Press PEAK key and hold, then press POWER key and release. In this setting; UNIT : Change sign, number and memory mode PEAK : Change the setting content ZERO : Shift the digit MEM : Register the setting content

5.2.Measuring Mode

There are standard measuring mode and peak hold mode in the measuring mode.

5.2.1Standard measuring mode

It's available to measure the compression and tension force. Measuring value is appeared at all times.

- 1) Press POWER key and release (Turn POWER on after release)
- 2) Press ZERO key to tare.

Displayed measuring value is averaged out the sampling value (every 1 msec *) per display update time.

Display update time of default factory setting is 3 times/second. In order to increase the display response against the change of measuring value, you may change the set value of display update time.

You can increase this time up to 20 times/second (regarding the change of display update time, please refer "4.5.2. Display update time").

※ It is depend on the setting of filter (f05). Please refer "4.5.5. Measuring filter" .

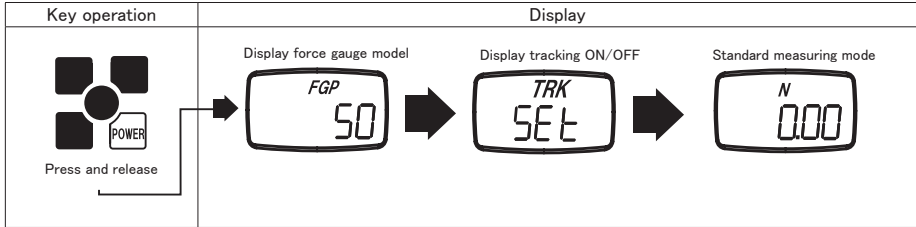

5.2.2 Peak hold mode

Display peak measuring value. Sampling time is 1ms. *

Press PEAK key to change standard measuring mode, Plus peak hold mode and Minus peak hold mode.

Under the plus peak hold mode, "PEAK" is appeared.

Under the minus peak hold mode, "PEAK" and "-" (minus) are appeared.

※ It is depend on the setting of filter (f05). Please refer "4.5.5. Measuring filter" .

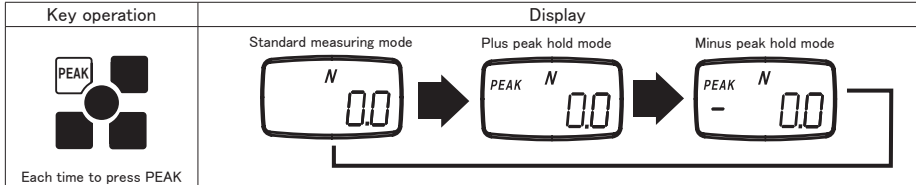

Under the plus peak hold mode and minus peak hold mode, press ZERO key to clear the peak value (Tare is not performed).

5.3.Change display unit

To change the display units, just press UNIT and the units will change every time the button is pressed.

N → kg (g) → lb (oz) → N

5.4.Tare

Press ZERO key to reset the measuring value. Please press the ZERO key before starting the measurement in order not to change the starting display value because of the own weight or measuring direction or weight of measuring fixture.

Measuring range is from maximum pulling load to maximum compression load. When measuring range is over, "OVR" is displayed.

Press the ZERO key under the plus peak hold mode or minus peak hold mode, plus peak value or minus peak value is cleared. At the plus peak hold mode and minus peak hold mode, tare does not performed even if press and release ZERO key.

When turning POWER on, tare is automatically performed (if you turn POWER on during the getting load, display becomes "0" and you cannot measure accurate value).

5.5.Comparator

5.5.1.Comptrator

Compare HI / LO limit which you entered to measuring value, then result is appeared in the display.

In addition, output signal of the result is available with data output port.

In order to active comparator function, you have to set "Hi-Lo" at "External output (f06)" at function setting. (When you set "ovEr" at the External output (f06), result does not appear and output signal is not performed.)

5.5.2.How to enter Comparator / Memory setting mode

Turn POWER off, press PEAK key and hold, then press POWER key and release (release PEAK key after the value is displayed more than 1 second).

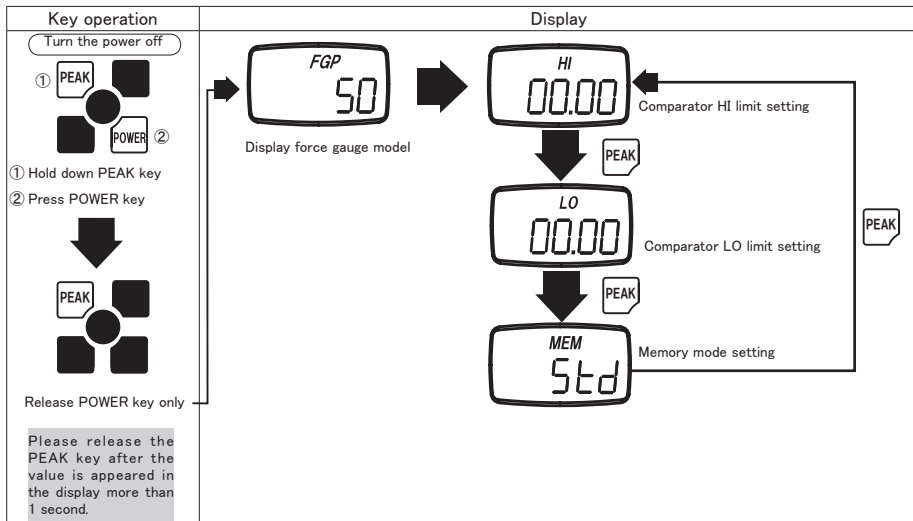

There are following setting items for comparator /memory setting mode.

Item	Display	Content of setting	Default factory setting
Comparator HI limit	HI	Set the comparator HI limit※	0
Comparator LO limit	LO	Set the comparator LO limit※	0
Memory mode setting	MEM	Set the memory mode (single mode, continuous mode, standard mode)	Std

When you set "0" at both HI limit and LOW limit, comparater function does not work.

5.5.3.Setting HI limit

- Press the UNIT key then all 4 digits turn on and off. Press the UNIT key once more, you can chose sign (plus or minus).
- Choose 0,1,2,3,4,5,6,7,8,9 at 4 ~ 1 digit (when you press UNIT key at 9, it turns 0). Press ZERO key to move right one digit. In this case, chosen number is displayed with unit which is chosen at standard measuring mode. (When you change the unit at standard measuring mode after the setting of HI limit, the conversion of the unit for HI limit value is not performed. After the change of the unit, please set the HI limit again.)
- Press PEAK key, then move to the setting of comparator LO limit
- Press MEM key, then setting value is registered and move to standard measuring mode.
- When you set both HI and LO limit with "0", comparater function does not work.

NOTICE



You can set the value regardless of rating capacity. In the case you set the value which is out of the range for rating capacity, comparator function might not work properly.

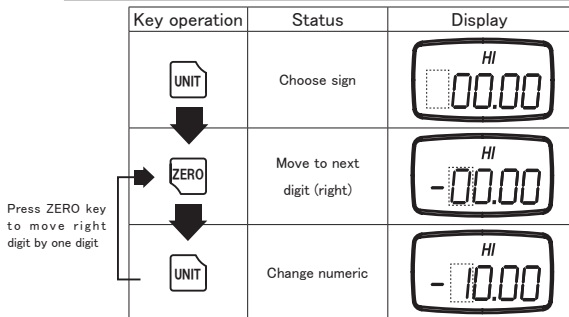

Key operation	Status
	Move to LO limit setting.
	Register the setting, then move to standard measuring mode.
	Turn power off without any change.

When you press ZERO key at first digit, move to 5th digit.



5.5.4. Setting LO limit

- (1) Press PEAK key during comparator HI limit setting, then move to LO limit setting.
- (2) Setting way is the same as the comparator HI limit setting.
- (3) Press MEM key, then setting value is registered, and move to standard measuring mode.
- (4) When you set HI and LO limit with "0", comparator function does not work.

LO limit setting mode



Key operation	State
	Move to memory mode.
	Register the setting, then move to standard measuring mode.
	Turn power off without any change.

5.5.5. Judgement on LCD

Compare the measuring value to comparator HI / LO limit value, then show Δ ∇ after the unit.

" Δ " means measuring value > HI limit

" ∇ " means measuring value < LO limit

Relation between judgement and display is as follows.

	Data \leq HI limit Data \geq LO limit	Data > HI limit Data \geq LO limit	Data \leq HI limit Data < LO limit	Data > HI limit Data < LO limit
In case of N (unit)				

※ In order to active the display of comparator judgement, you have to set "Hi-Lo" at function mode " External output (f06)" .

5.5.6. Output signal of judgement

Compare the measuring value to comparator HI / LO limit value, then the signal of comparator judgement will be outputted through the data output port.

Measuring value > HI limit value \Rightarrow Turn on output signal of comparator HI limit.

Measuring value < LO limit value \Rightarrow Turn on output signal of comparator LO limit.

※ In order to active output signal of comparator judgement, please set "Hi-Lo" at function mode " External output (f06)" .

5.6. Memory

There are 3 modes at memory mode as follows.

Continuous memory	Memorize 1000 data at maximum which is measured between press MEM key and press MEM key next time. In addition, statistical data of memory data (plus maximum value, minus maximum value, plus minimum value, minus minimum value, plus peak value, minus peak value, average value, standard deviation) is displayed.
Single memory	Every time press MEM key, display value (under the standard measuring mode: measuring value, under the peak hold mode: peak value) is memorized at this point up to 100 data. In addition, statistical data of memory data (plus maximum value, minus maximum value, plus minimum value, minus minimum value, average value, standard deviation) is displayed.
Standard memory	Memorize statistical data (plus maximum value, minus maximum value, plus minimum value, minus minimum value, plus peak value, minus peak value) and last measuring data which is measured between press MEM key and press MEM key next time. Memorize up to 50 data.

[Definitions of the terms]

Measuring value: Displayed value which is per display update time at standard measuring mode.

Plus maximum value (+MAX): Maximum value at plus side which is measured within memory measuring interval.

Minus maximum value (-MAX): Maximum value at minus side which is measured within memory measuring interval.

Plus minimum value (+MIN): Minimum value at plus side which is measured within memory measuring interval.

Minus minimum value (-MIN): Minimum value at minus side which is measured within memory measuring interval.

Example of +MAX, -MAX, +MIN, -MIN (Continuous memory mode)

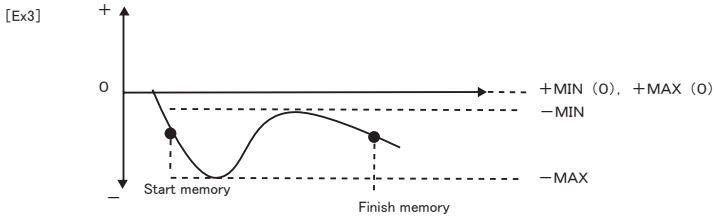
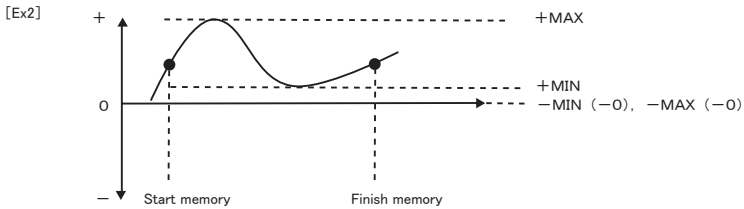
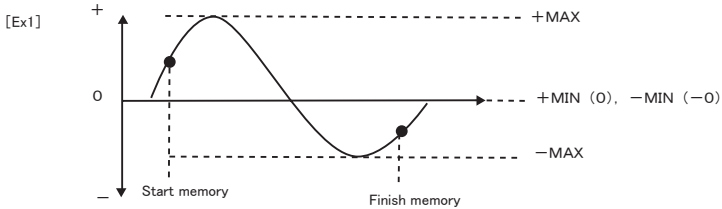

- Average value (AVE) : Average value of measuring value which is measured within memory measuring interval. $\sum X_i/n$
- Standard deviation (DEV) : Standard deviation of measuring value which is measured within memory measuring interval. $\sqrt{\sum (X_i - \bar{X})^2/n}$
- Plus peak value : Plus peak value within memory measuring interval (Maximum value within sampling interval 1000 times/second).
- Minus peak value : Minus peak value within memory measuring interval (Minimum value within sampling interval 1000 times/second)
- Last measuring value (LST) : Value which is measured in the end of memory measuring interval.

5.6.1. Setting memory mode

Turn the POWER off. Press PEAK key and hold, then press POWER key. Comparator HI limit setting turns on, then press PEAK key twice. Memory setting mode turns on.

There are following setting items for comparator • memory setting mode.

Item	Display	Content	Default factory setting
Comparator HI limit setting	HI	Set comparator HI limit ※	0
Comparator LO limit setting	LO	Set comparator LO limit ※	0
Memory mode setting	MEM	Set memory mode (Single mode, Continuous mode, Standard mode)	Std

※ When you set "0" at both HI limit and LO limit, comparator function does not work.

At memory mode setting, you can set single memory, continuous memory, standard memory.

- (1) Switch memory mode (SinG (single memory mode), Cont (continuous memory mode), Std (standard memory mode)) by UNIT key.
- (2) Press PEAK key to move comparator upper limit setting.
- (3) Press MEM key to register the setting, and move to standard display.

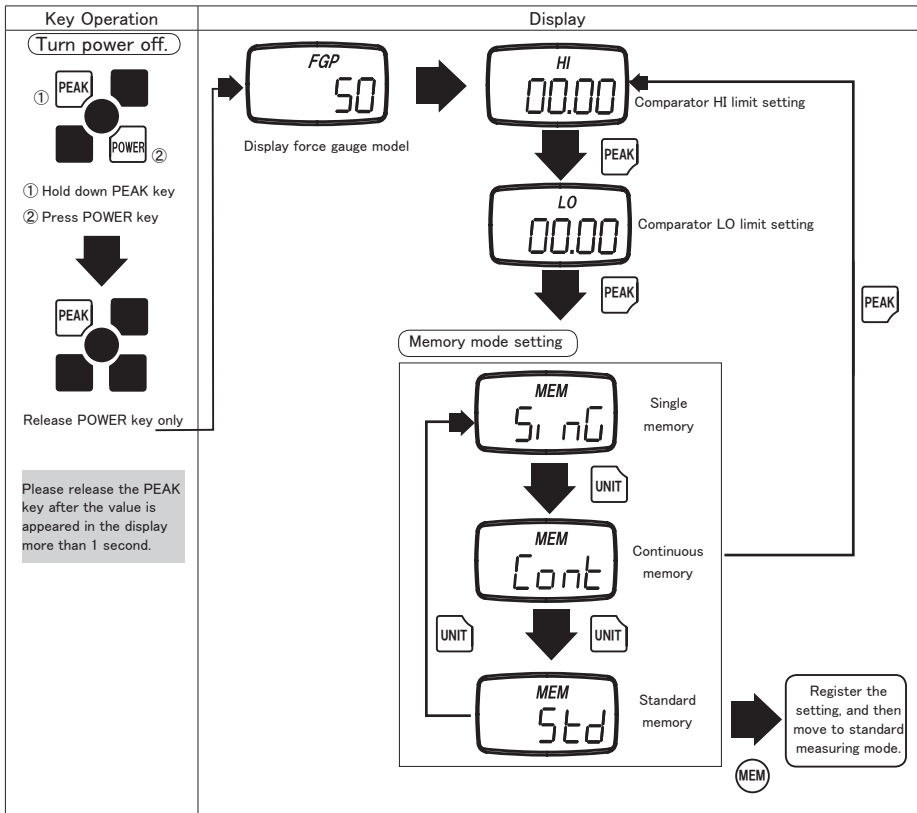

5.6.2. Storing data

Store the data at setting memory mode (single memory, continuous memory, standard memory).

5.6.2.1. Store the data (Continuous memory mode)

- (1) During the standard measuring mode, please press MEM key. Then "M" blink, start the record. Press MEM key, measurement is finished, and then display of the unit is changed from M into the unit.
- (2) When the memory number arrive at 1000 during the record, "FULL" appear at the display of measuring value, then record is finished and move to standard measuring mode.

Key operation	Status	Display (" " means blinking)
(MEM)	Standard measuring mode	
—	Registering the data	
(MEM)	The record is finished	

When amount of memory number arrive at 1000

5.6.2.2. Store the data (Single memory mode)

- (1) During the standard measuring mode, please press MEM key. Then "M" turn on at the unit display and the present display (one data) is recorded.
- (2) If 100 data are already recorded, "FULL" appears for 1 second at the value display. Then move to standard measuring mode.

Key operation	Status	Display
(MEM)	Standard measuring mode	
—	Registering the data	

When amount of memory number arrive at 100

5.6.2.3. Store the data (Standard memory mode)

Press MEM key during the standard measuring, then "M" blink at the unit display, start the record. Press MEM key again to finish measurement, then display of the unit return to the unit display.

Key operation	Status	Display (" " means blinking)
(MEM)	Standard measuring mode	
—	Registering the data	
(MEM)	The record is finished	

When amount of memory number arrive at 50

5.7.Recalling memory data

5.7.1.Continuous memory mode

5.7.1.1.Measuring memory data

- (1) Turn the POWER off. Press MEM key and hold, then press and release POWER key (release MEM key after the value appear in the display more than 1 second), then move to display measuring memory data.
- (2) Start to display from the last memory data which is recorded. Memory number and data appear one after the other.
- (3) Press MEM key to display previous memory number (when memory number is 1, move to last memory data number).
- (4) Press PEAK key to output with RS-232C (regarding output format, please download "FGP series RS-232C communication command list" from our web site. And, please refer "6.2.2. RS232C communication command" for the detail). Move to standard measuring mode.

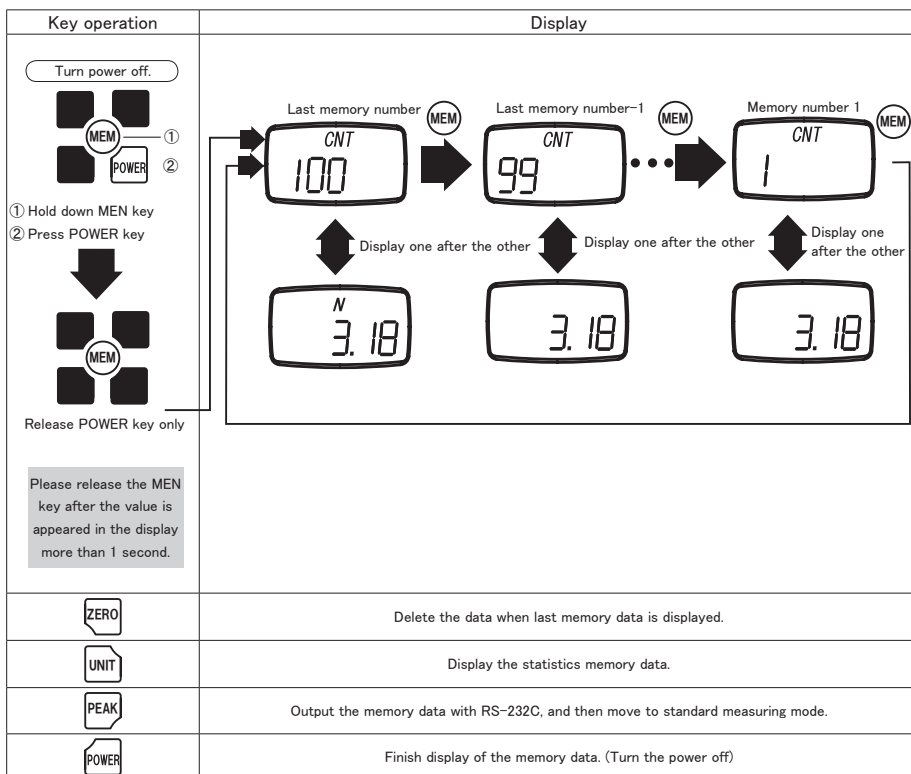

5.7.1.2. Statistics memory data

- (1) Press UNIT key during the measuring memory data, statistical data appear.
- (2) Every time press UNIT key, switch the display item, plus maximum value → minus maximum value → plus minimum value → minimum value → minus minimum value → plus peak value → minus peak value → average value → standard deviation.
- (3) Press MEM key during the statistical data, measuring memory data appear.
- (4) Press PEAK key to move RS-232C output (regarding output format, please refer "6.2.2. Communication command of RS-232C").
Move to standard measuring.

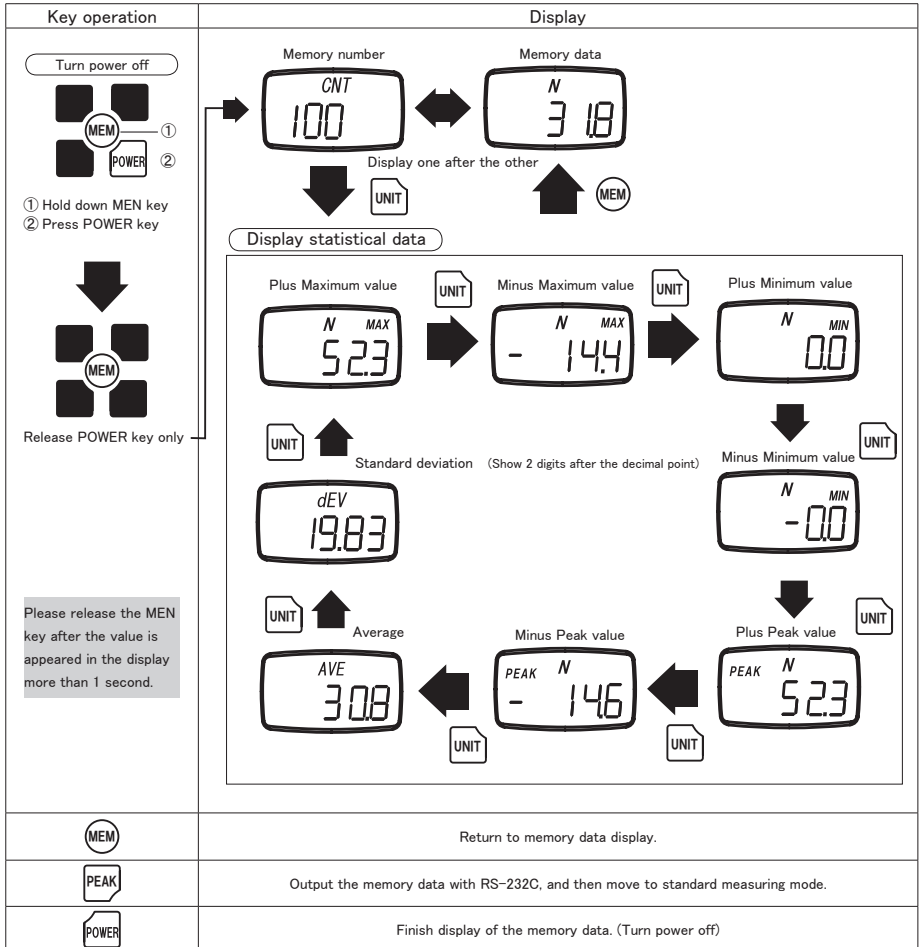

5.7.2. Single memory mode

5.7.2.1. Measuring memory data

- (1) Turn POWER off. Press MEM key and hold, then press and release POWER key (release MEM key after the value appear in the display more than 1 second), then measuring memory data is displayed.
- (2) Start to display from the last data and show memory number and data alternately.
- (3) Press MEM key to display previous memory number (when memory number is 1, move to last memory data number).
- (4) If PEAK key is pressed, output of RS-232C is processed. (Regarding the output format, please download "FGP series RS-232C communication command list" from our web site. Please refer to "6.2.2. RS-232C communication command" for the detail.) Move to standard measuring mode.

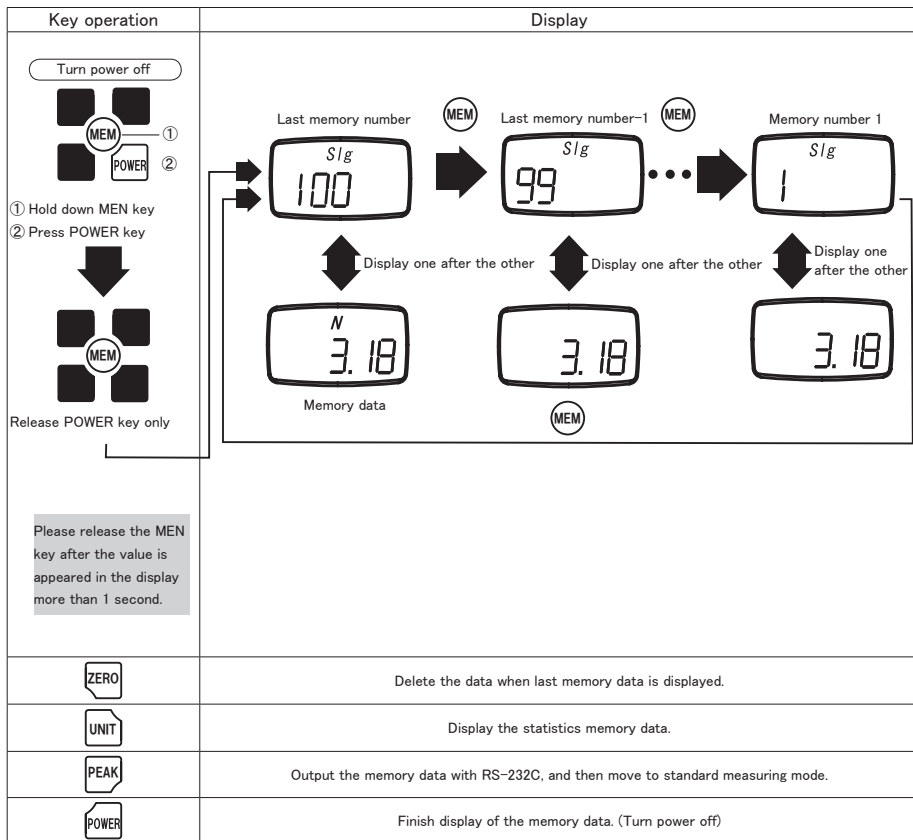

5.7.2.2. Statistics memory data

- (1) When measuring memory data is displayed, the display shifts to statistical memory data by pressing UNIT key.
 - (2) Each time you press UNIT key, the display switches in order of plus maximum value → minus maximum value → plus minimum value → minus minimum value → average value → standard deviation.
 - (3) When statistical memory data is displayed, the display shifts back to measuring memory data if you press MEM key.
 - (4) If pressing PEAK key, output of RS232C is processed and then display shifts back to standard measuring mode.
- (Regarding the output format, please download "FGP series RS-232C communication command list" from our web site.
Please refer to "6.2.2. RS-232C communication command" for the detail.)

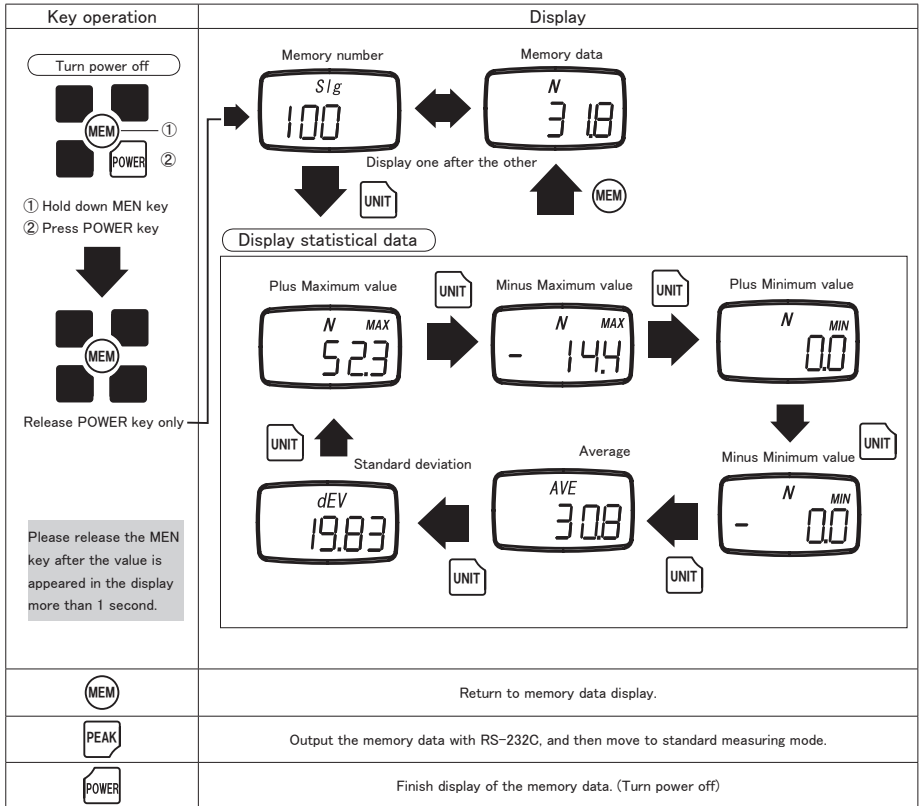

5.7.3. Standard memory mode

5.7.3.1. Measuring memory data

- (1) Turn POWER off. Press MEM key and hold, then press and release POWER key
(release MEM key after the value appear in the display more than 1 second), then measuring memory data is displayed.
- (2) Start to display from the last data and show memory number and data alternately.
- (3) Press MEM key to display previous memory number (when memory number is 1, move to last memory number).
- (4) If PEAK key is pressed, output of RS-232C is processed. Then display shifts back to measuring mode.
(Regarding the output format, please download "FGP series RS-232C communication command list" from our web site. Please refer to "6.2.2. RS-232C communication command" for the detail.)

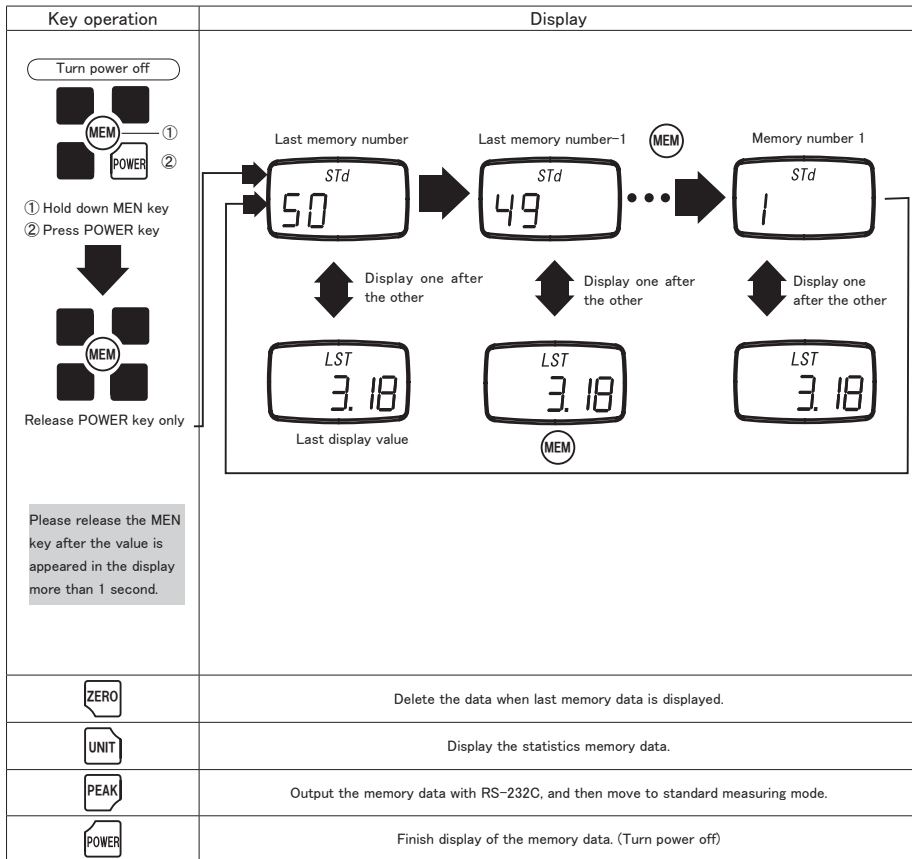

5.7.3.2. Statistics memory data

- (1) When measuring memory data is displayed, display shifts to statistics memory data by pressing UNIT key.
- (2) Each time you press UNIT key, display switches in order of plus maximum value → minus maximum value → minus minimum value → plus minimum value → plus peak value → minus peak value → minus minimum value → plus peak value → minus peak value → plus minimum value.
- (3) When statistics memory data is displayed, display shifts back to measuring memory data if you press MEM key.
- (4) Output of RS-232C is processed if you press PEAK key and display shifts to standard measuring mode. (Regarding the output format, please download "FGP series RS-232C communication command list" from our web site. Please refer to "6.2.2. RS-232C communication command" for the detail.)

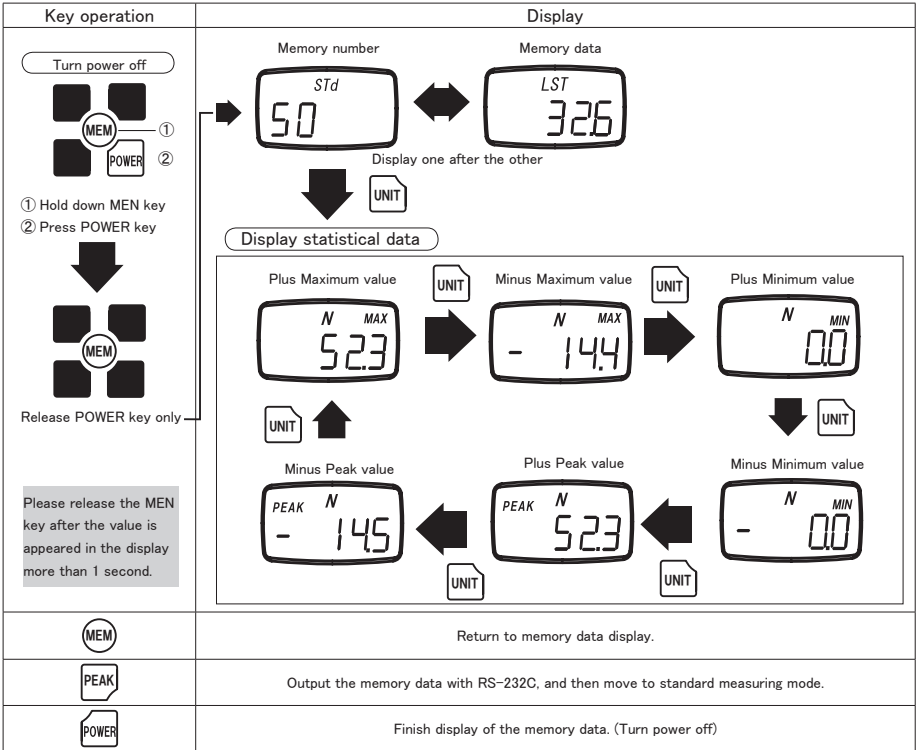

5.8. Erasing memory data

5.8.1. Elimination of one last data

- (1) When last measuring memory data is displayed, last data is erased if you push ZERO key. The memory data before erased last data will be memory number of last data, and then display shifts to measuring memory data.
- (2) If you press ZERO key except when last data is displayed, display shifts to measuring memory data after "Err" is displayed for one second at measuring display.

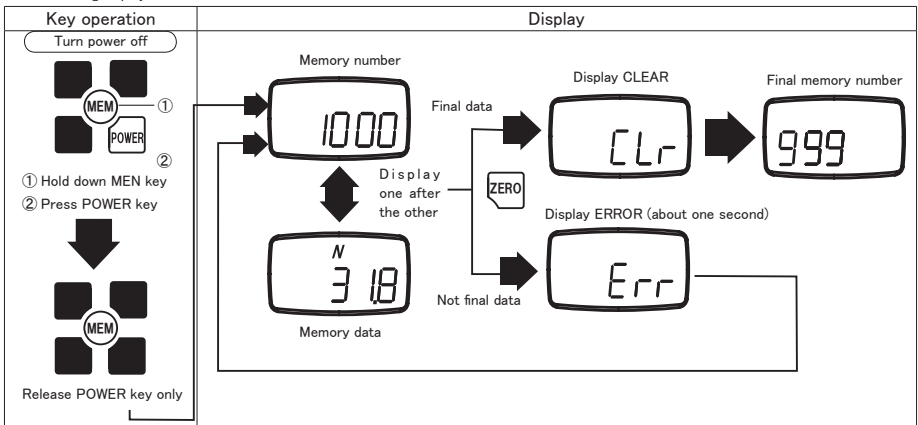

5.8.2.Erasing all memory data

- (1)When last memory data is displayed, all data will be erased if you press ZERO key for a long time.
- (2)Display switches to standard measuring mode after showing "nonE" for one second at measuring display.
- (3)All memory data of current memory mode is erased.

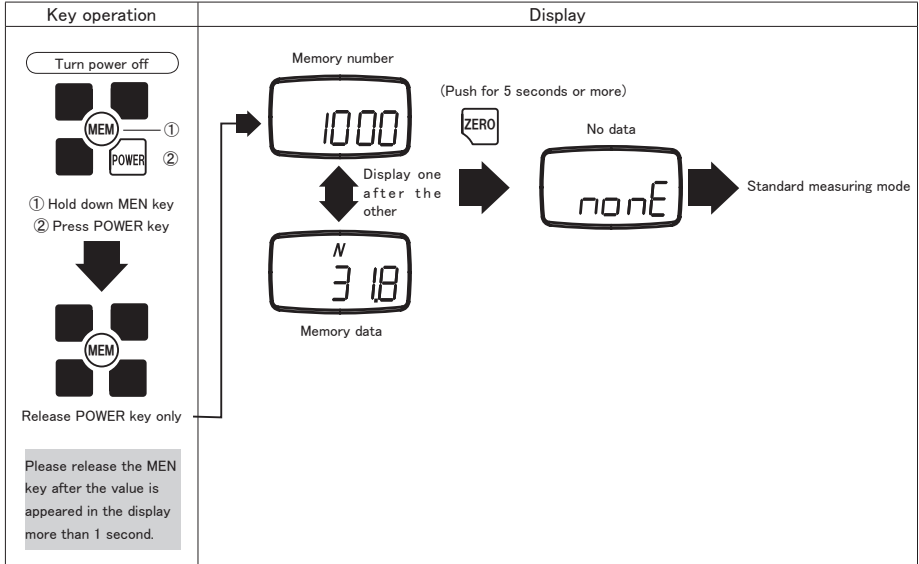

5.8.3.No memory data

Display shows "nonE" if switching to measuring memory data display mode.



When measuring memory data is displayed and these are not any memory data.

After display "nonE" for one second, move to standard measuring mode.

5.9.USB communication

If you connect force gauge and PC with the attached USB cable, you can download the data from FGP to PC. (Real time data of measuring value or memory data.) Please install special communication software "TorieomonUSB" into your PC.

5.9.1.Features of TorieomonUSB

You can take measuring data or memory data of force gauge directly into the excel seat by using "Torieomon USB" which is Excel add-in software.That is why you can analyze the taken data or make graphs easily.

※ Microsoft Excel is registered as trademark of Microsoft Corporation in U.S.A.

5.9.2.Download TorieomonUSB

Please access our web site (<http://www.nidec-shimpo.co.jp/en/is/fg/fgp/index.html>) and register download. After registration, you will get ID and password, and then access download site to download "TorieomonUSB" .

If you doubleclick the downloaded file, PDF file "Torieomon USB instruction manual" is made in the same holder with the downloaded file. Please refer to the content of this instruction manual regarding the installing procedure of Torieomon USB, function explanation, and operating procedure.

5.9.3.Precaution when using USB communication

Do not leave USB cable connected for a long time. If you leave USB cable connected, battery power tends to be burn battery power early even if the power of force gauge is off. (No problem for using AC adapter)

6.External Connection Connection

6.1.Pin assignment

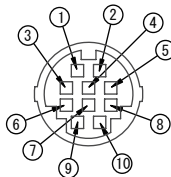
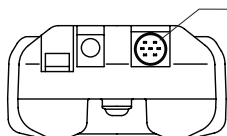

HR12-10RC-10SDL made in Hirose is used for connector. We recommend you to use HR12-10P10PCAE300 (10 wires sealed cable) when making cable on your own.

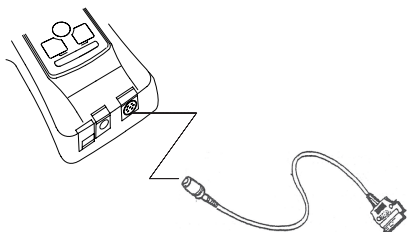

RS232C communication
cable: 2 m
(Option)

Pin Number	Signal Name
①	Analog +
②	Analog GND
③	RxD (RS-232C Received data) Host computer ⇒ FGP
④	Digital GND
⑤	Detection of Connection
⑥	TxD (RS-232C Transmitted data) FGP ⇒ Host computer
⑦	(Connection disabled ※1)
⑧	Compression overload / LO output of comparator ※2
⑨	Tension overload / HI output of comparator ※2
⑩	Common of overload / comparator

※1 Please leave the pin ⑦ is always unconnected.

※2 Switch of overload output/comparator output can be set by external output setting (f06) of function mode.

6.2.RS232C Output

You can operate this equipment from your PC if connecting it by using optional cable for RS-232C.

6.2.1.RS232C interface

Baud rate ※	: 2400, 4800, 9600, 19200bps
Length of data bit	: 8bit
Parity bit	: None
Length of stop bit	: 1bit
Flow control	: None

※ Please set baud rate according to RS-232C baud rate setting (f04) of function setting.

Default factory setting is 2400 bps. Please use your equipment as the above parameter.

Alphanumeric characters and carriage return (cr) of ASCII code is used for transmitting data.

6.2.2.RS232C communication command

■ Typical communication command

“cr” means carriage return.

Transmitting command from host computer to FGP	Content	Returning command from FGP	Explanation	
AAcr	Tare	AAcr		
ABcr	Cancel of data transmission	ABcr		
ACcr	Switch to plus peak hold mode	ACcr		
ADcr	Switch to standard measuring mode	ADcr		
ALcr	Switch to minus peak hold mode	ALcr		
AEcr	Clear the plus/minus peak value to zero	AEcr		
AFcr	Switch the unit to kg	AFcr		
AGcr	Switch the unit to N	AGcr		
AHcr	Switch the unit to lb	AHcr		
AKcr	Switch the unit to oz	AKcr		
BAcr	Transmission request of one measuring data (measuring value at present)	BAcr NA□□□□□□cr	□□□□□□ : 6-digit value including sign, decimal point and 4-digit number	
BBcr	Request for continuous transmission of measuring data (10 times/second)	BBcr NA□□□□□□cr		
BB1cr	Request for continuous transmission of measuring data (20 times/second)	BB1cr NA□□□□□□cr		
BB2cr	Request for continuous transmission of measuring data (50 times/second)	BB2cr NA□□□□□□cr		
BB3cr	Request for continuous transmission of measuring data (100 times/second)	BB3cr NA□□□□□□cr		
BCcr	Transmission request of model	BCcr NE□□cr	□□ : 2-digit number indicating model 02 : FGP-0.2 03 : FGP-0.5 04 : FGP-1 05 : FGP-2 06 : FGP-5 07 : FGP-10 08 : FGP-20 09 : FGP-50 1A : FGP-100	
BDcr	Transmission request of unit	BDcr NH□cr	□ : one-digit number indicating unit 0 : N, 1 : kg, 2 : g, 3 : lb, 4 : oz	
BEcr	Transmission request of plus peak value	BEcr NB□□□□□□cr	□□□□□□ :	
BFcr	Transmission request of minus peak value	BFcr NC□□□□□□cr	6-digit value including sign, decimal point and 4-digit number	
In the communication with host computer, when FGP detect communication error, transmit the error command.			OBcr OFcr OHcr	Command format error (mistake command) Flaming error Overrun error

■ Other communication command

Other than those above, a lot of communication commands are prepared.

Please access our web site (<http://www.nidec-shimpo.co.jp/en/is/fg/fgp/index.html>) and register download.

After registration, you will get ID and password, and then access download site to download "FGP RS-232C communication command table".

6.2.3.Connection between FGP and PC

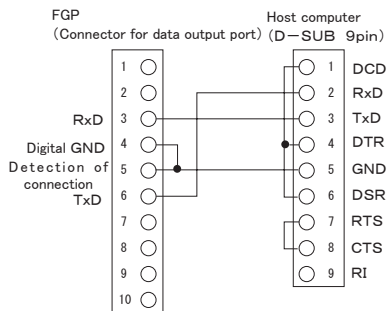

Please be sure to connect 5pin into 4 pin of digital GND when making cable for RS-232C on your own. It cannot be transmitted without this connection.

6.3.Analog output

Output $\pm 1V$ for display range.

Output plus voltage when measuring value is plus (when compressing) and minus voltage when measuring value is minus (when tensioning). Output will be nearly 0 V if you press ZERO key and tare.

Output signal	$\pm 1V$ (\pm Range which display is possible)
Signal method	12 bit D/A converter method
Output update	1000 times / second *
Load resistance	10 k Ω or more
Output accuracy	$\pm 50mV$

The data will be updated 1000 times for one second as the measuring value is changed to analog by 12 bit D/A converter. Please adjust output to 0 V on your own since this equipment cannot respond to it. Load resistance is 10k Ω or more.

When using analog cable (option), please plug the connector side of cable into connector for data output port of FGP and connect red banana plug into plus and black banana plug into minus.

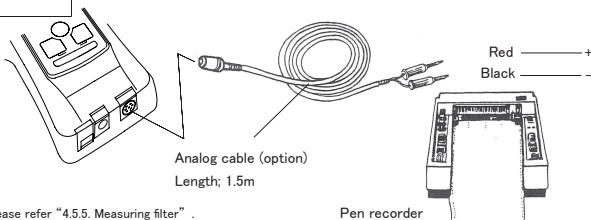

※ 't' s depending on the measuring filter setting (f05). Please refer "4.5.5. Measuring filter" .

6.4.Overload/Comparator output

Output overload/comparator signal.

Switch of output overload/comparator signal is set by external output setting (f06) of function mode.

● I/F Circuit

Compressing overload
/ LO output of comparator 8pin

Tensioning overload
/ HI output of comparator 9pin

Common of overload /
comparator 10pin

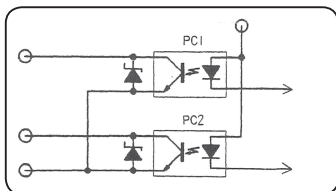

Maximum allowance voltage DC 30V / current 5mA



Please connect the power and load to avoid going over maximum allowance.

● Overload output

Output signal ※ when overloaded. If you use it with installing other equipment or it is installed in motorized test stand, security alarm can be connected and protect the force gauge.

If overloading works toward the compressing direction, photo-coupler PC1 will be on and the current flows.

If overloading works toward the tensioning direction, photo-coupler PC2 will be on and the current flows.

If not overloaded, photo-coupler of PC1 and PC2 will be off and the current doesn't flow.

※ Output when overloading is about 120% (not including tare value) of rating capacity.

● Comparator output

When HI output of comparator is on, photo-coupler PC2 will be on and current will flow.

When LO output of comparator is on, photo-coupler PC1 will be on and current will flow.

Please refer to "5.5. Comparator" regarding the detail of comparator function (how to set HI and LO value of comparator, judgment condition of comparator.)

7.Frequently –asked questions

7.1.Questions for trouble

Questions	Cause	Presumable reason	Procedure
When turning on power, “OVR” is displayed even if not applying load and cannot be cleared by pushing ZERO key.	There is possibility which internal loadsell is broken.	Due to dropment or overloading	Please send it for repair.
“Low bat” is displayed at LCD even if charging up for more than one day.	Voltage of battery is low.	<ul style="list-style-type: none"> • End of battery life • Breakdown of battery • Breakdown of charging 	Please send it fot repair.
It doesn't display even if pressing POWER Key.	Battery is weak.	Voltage of battery is lower.	Please charge a battery.
	“BAT” isn't displayed on LCD even if charging up.	<ul style="list-style-type: none"> • Breakdown of battery • Breakdown of internal circuit • Breakdown of AC adapter 	Please send it for repair.
The value becomes “0” automatically when measuring small value near 0.	You can use tracking to prevent the fluctuation of the measuring value near “0”.	Tracking is on.	Please set tracking off. (Refer to “4.4.Tracking”)
Value changes if you change the direction of force gauge.	This is not breakdown. This equipment is measuring the empty weight of sensor on his own.	Sensor or tools also have weight empty operating.	Push ZERO key after setting the direction to measure and clear the measuring value.
Although I downloaded “Toriemon” , it doesn't work even if connecting force gauge.	-	Since “Toriemon” is soft forRS-232C transmission, it doesn't respond to USB transmission.	Please download “ToriemonUSB” and use it.

7.2.Questions for technical

Questions	Explanation	Reference
How long does rechargeable battery (Nickel hydride battery) last?	Enable to use 500 times or more by complete electric discharge. It depends on the status of use.	Please charge battery after discharging electricity until “LO BAT” is displayed at LCD.
Why are there various rating capacity?	The value is more accurate when measuring near rating as much as possible.	It is ideal to use this equipment with 50% rating or more.
Why does measuring data show variations?	Although there are many reasons, the measuring value is affected by vibration if you hold by hands.	Fluctuation will be reduced when using stand.
How does biased loading affect accuracy?	Although it depends on the angle, you cannot measure accurate value with biased loading.	
How do you proceed ISO caribration ?	It measures the value by pushing or pulling load by certificated weight.	Weight with traceability is necessary.
Please tell easy test methods which user can.	Please hang the weight which is clear.	
Can user exchange battery?	User cannot exchange battery.	Please let our dealers know since exchange of battery is as repairment.
Do you have CAD data?	Yes.	Please let our dealers know.
Is it possible to use in water?	No. It is not waterproof structure.	Please pay attention not to pour water.

8.Support

8.1.Repair and Calibration

We have calibration service for value. We recommend calibrating regularly for keeping up the accuracy of force gauge. Please ask our dealers for the price and lead time of the calibration.

8.2.Warranty

Nidec-Shimpo Corp. warrants, to the original purchaser of new products only, that this product shall be free from defects in workmanship and materials under normal use and proper maintenance for one year from the date of original purchase.

9.Specifications and Dimensions

Model	FGP-0.2	FGP-0.5	FGP-1	FGP-2	FGP-5	FGP-10	FGP-20	FGP-50	FGP-100
Capacity(R.C.)	± 2.000 N (± 200.0 g) (± 8oz)	± 5.000 N (± 500.0 g) (± 16oz)	± 10.00 N (± 1000 g) (± 2 lb)	± 20.00 N (± 2.000 kg) (± 5 lb)	± 50.00 N (± 5.000 kg) (± 10 lb)	± 100.0 N (± 10.00 kg) (± 20 lb)	± 200.0 N (± 20.00 kg) (± 50 lb)	± 500.0 N (± 50.00 kg) (± 100 lb)	± 1000 N (± 100.0 kg) (± 200 lb)
Display range	± 2.000 N ± 200.0 g ± 8oz	± 5.000 N ± 500.0 g ± 16oz	± 10.00 N ± 1000 g ± 2 lb	± 20.00 N ± 2.000 kg ± 5 lb	± 50.00 N ± 5.000 kg ± 10 lb	± 100.0 N ± 10.00 kg ± 20 lb	± 200.0 N ± 20.00 kg ± 50 lb	± 500.0 N ± 50.00 kg ± 100 lb	± 1000 N ± 100.0 kg ± 200 lb
Resolution	0.001N 0.1g 0.01oz	0.01N 1g 0.001lb	0.01N 1g 0.001lb	0.01N 0.001g 0.001lb	0.01N 0.001g 0.01lb	0.1N 0.01kg 0.01lb	0.1N 0.01kg 0.1lb	0.1N 0.01kg 0.1lb	1N 0.1kg 0.1lb
Unit	N, kg(g), lb(oz) (Reversible display)								
Measuring mode	Standard measuring, Plus peak measuring, Minus peak measuring								
Display cycle	1, 2, 3, 5, 10, 20 times per second								
Sampling Rate	1000 times per second								
Accuracy	± 0.2% R.C. ± 1/2digit(23°C)								
Influence of temperature	Gain : ± 0.01% LOAD/°C Zero : ± 0.01% /R.C./°C (Drift of zero point can be cancelled with tracking function.)								
Display	Main display: 4-digits 12mm high, Reversible display Unit display: 3-digits 7mm high Other display: ① "LO BAT"(Decrease battery voltage), ② "BAT"(Battery charge), ③ "OVR"(Over load), ④ "Peak"(Peak hold mode)								
Overload	200%R.C.								150%R.C.
Tracking	Available(ON/OFF)								
Output	USB	Communicate with PC by special application software (maximum 100 times per second). Connection cable is standard accessory.							
	RS-232C	Communicate with PC by special command (maximum 100 times per second). Connection cable is option.							
	Analog	± 1V, Accuracy ± 50mV, through a 12 bit D/A converter. Output update 1000 times per second. Acceptable tare, Load resistance is more than 10k Ω							
Overload/Comparator	Open-collector output (Max DC30V/5mA). Either overload output or comparator output								
Power	Rechargeable Nickel hydride battery or AC adapter/charger, Measurable during the charge. Operating hours: about 8 hours after full charge, Charging time: Max 16 hours (when the battery is full, charge is finished automatically.)								
Auto Power Off	10 minuts (not active if adapter/charge is in use) or OFF								
Memory function	Continuous memory: 1000 data, Single memory: 100 data, Standard memory: 50 data Statistic function (max, minimum, peak, average, standard deviation)								
Comparator function	Yes(high and low)								
Temperature range	0 ~ 40° C no condensation								
Humidity range	35 ~ 85%RH no condensation								
Dimensions	147mm ※ (L) x 75mm (W) x 38mm(H)								
Weight	Approx. 450g								Approx. 500g
Accessories (Included)	AC adapter/charger, carrying case, hook, chisel, flat head, notched head, hanger, cone head, extension rod, USB cable								
Application software	Application software (USB version), Available to download ToriemonUSB from our website free of charge.								

※ Dimension for FGP-0.2 ~ 0.5 is 141mm, FGP-100 is 149mm.

Dimensions

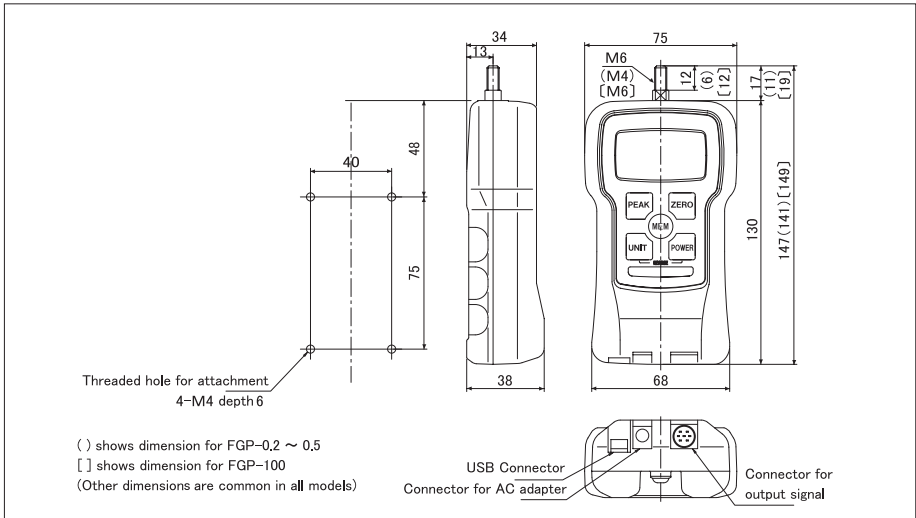

Force measuring attachments (standard accessories)

The following drawing is for the attachment of FGP-2 ~ 50 (M6).
Please contact our dealers about the adapter for FGP-0.2, 0.5 (M4) and FGP-100 (M6).

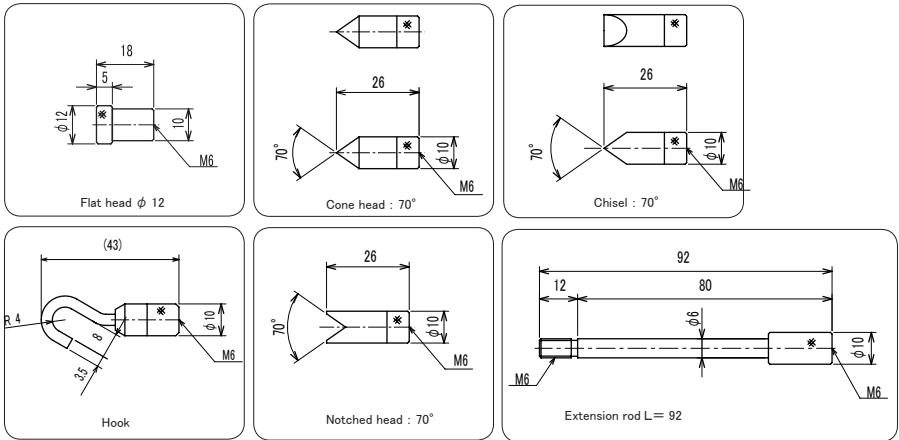

SCHMIDT

control instruments

SCHMIDT-Test-Instruments
*indispensable in production monitoring,
quality control and automation*
We solve your measuring problems:



Tension Meter



Force Gauge



Torque Meter



Tachometer



Speed- and Lengthmeter



Electronic Lengthmeter



Stroboscope



Screen Printing Tension Meter



Thickness Gauge



Yarn Package Durometer and Shore-A Durometer



Sample Cutter



Balance



Moisture Meter



Leak Tester



Softometer

More than 60 years - Worldwide -

Hans Schmidt & Co GmbH

Mailing address:

P. O. B. 1154
84464 Waldkraiburg Germany

Shipping address:

Schichtstr. 16
84478 Waldkraiburg Germany

Phone:

int. + 49 / (0)8638 / 9410-0

Fax:

int. + 49 / (0)8638 / 4825

int. + 49 / (0)8638 / 67898

e-mail:

info@hans-schmidt.com

Internet:

<http://www.hans-schmidt.com>