



- Model FS1
- FSP
- FSH
- FSW
- FSL
- FSB1

Instruction Manual

Valid as of: 01.10.2012 • Please keep the manual for future reference!



Contents

1	Warranty and Liability	3
1.1	Notices within the Operating Instructions	3
1.2	Responsibilities of the Operating Company	3
1.3	Responsibilities of the Personnel	3
1.4	Informal Safety Measures	4
1.5	Training of the Personnel	4
1.6	Intended Use	4
1.7	Dangers in Handling the Device	4
1.8	Copyright	4
1.9	Declaration of Conformity, RoHs II and WEEE Registration	4
2	Available Models	5
2.1	General Information	5
2.1.1	Available FS1 Models	6
2.1.2	Available FSP Models	7
2.1.3	Available FSH Models	7
2.1.4	Available FSW Models	8
2.1.5	Available FSL Models	8
2.1.6	Available FSB1 Models	9
2.2	Specifications of the FS Series	9
2.3	Assignment of the Connector	10
2.3.1	Connecting the Tension Meter	10
2.4	Optional Accessories	10
2.5	Delivery Includes	11
2.6	Unpacking	11
3	Operating Procedure	11
3.1	Mounting possibilities	11
3.2	Initial Setup	12
3.3	Internal Adjustment of the Sensors	12
3.3.1	ZERO Adjustment	12
3.3.2	GAIN Adjustment	13
4	Service and Maintenance	14
4.1	Rollers	14
5	Cleaning	14
6	Verification Interval	14
6.1	Verification of Calibration and Determination of Repair Costs	15
7	Correspondence	16
8	Repairs	16

1 Warranty and Liability

In principle, the supply of the device is subject to our "General Conditions of Sale and Delivery." These have been provided to the operating company on conclusion of the contract, at the latest.

Warranty:

- SCHMIDT tension meters are warranted for 12 months.

Parts subject to wear, electronic components and measuring springs are not covered by the warranty. No warranty or liability will be accepted for bodily injury or property damage resulting from one or several of the following causes:

- Misuse or abuse of the device.
- Improper mounting, commissioning, operation and maintenance of the device (e.g. verification interval).
- Operation of the device if any safeguards are defective or if any safety and protection precautions are not properly installed or not operative.
- Failure to comply with the notices in the Operating Instructions regarding transport, storage, mounting, commissioning, operation, maintenance and setup of the device.
- Any unauthorized structural alteration of the device.
- Insufficient inspection of device components that are subject to wear.
- Opening the device or improper repair work.
- Disasters caused by the effects of foreign objects or by force majeure.

1.1 Notices within the Operating Instructions

The fundamental prerequisite for the safe handling of this device and its troublefree operation is the knowledge of the basic safety notices and safety instructions.

These Operating Instructions contain the most important notices for the safe operation of the device.

These Operating Instructions, in particular the safety notices, must be observed by any person who works with the device. In addition, the local valid rules and regulations for the prevention of accidents must be complied with.

The representations within the Operating Instructions are not true to scale.

The dimensions given are not binding.

General indications of direction, such as FRONT, REAR, RIGHT, LEFT apply when viewing the front of the device.

1.2 Responsibilities of the Operating Company

In compliance with the EC Directive 89/655/EEC, the operating company agrees to only permit persons to work with the device who:

- are familiar with the basic regulations on industrial safety and accident prevention and who have been trained in handling the device.
- have read and understood the chapter on safety and the warning notices in these Operating Instructions and have confirmed this with their signatures.
- are examined regularly on their safe and conscientious working method.

1.3 Responsibilities of the Personnel

All persons who work with the device agree to perform the following duties before starting work:

- to observe the basic regulations on industrial safety and accident prevention.
- to read the chapter on safety and the warning notices in these Operating Instructions and to confirm with their signatures that they have understood them.

1.4 Informal Safety Measures

The Operating Instructions must always be kept on hand where the device is operated. Apart from the Operating Instructions, the general and local valid regulations on accident prevention and environmental protection must be provided and complied with.

1.5 Training of the Personnel

Only trained and instructed personnel is permitted to work with the device. The responsibilities of the personnel must be clearly defined for mounting, commissioning, operation, setup, maintenance, and repair. Trainees may only work with the device under the supervision of experienced personnel.

1.6 Intended Use

The device is intended exclusively to be used as a tension meter. Any other use or any use exceeding this intention will be regarded as misuse. Under no circumstances shall HANS SCHMIDT & Co GmbH be held liable for damage resulting from misuse.

The intended use also includes:

- Complying with all notices included in the Operating Instructions and observing all inspection and maintenance works.

1.7 Dangers in Handling the Device

The device was designed according to the state of the art and the approved safety standards. Nevertheless, its use may cause serious or fatal injury to the user or third persons, and/or an impairment of the device or of other material assets.

The device may only be applied:

- For its intended use in a faultless condition with regard to the safety requirements.
- Malfunctions that could impair safety must be remedied immediately.
- Personal protective equipment must be used according to the EC Directive 89/686/EEC.



The device must not be operated in potential explosive areas and must not come into contact with aggressive substances.

1.8 Copyright

The copyright on these Operating Instructions remains with the company HANS SCHMIDT & Co GmbH.

These Operating Instructions are intended for the operating company and its personnel only. They contain instructions and notices that may only be reproduced on the prior written permission of

HANS SCHMIDT & Co GmbH

and under indication of the complete reference data.

Violations will be prosecuted.

1.9 Declaration of Conformity, RoHs II and WEEE Registration

In compliance with the EU Directives 2014/30/EU and 2011/65/EU



HANS SCHMIDT & CO GmbH is registered in compliance with the German Electrical and Electronic Equipment Act (ElektroG) under WEEE Reg. No. DE 48092317.

2 Available Models

2.1 General Information

These Operating Instructions refer to the FS1 Model of the FS Series; they are also applicable to the following models:

FSP, FSH, FSW, FSL, FSB1

The individual models of the FS Series are also available with the following modifications (customized versions):

- Customized measuring head width
- Special tension ranges
- Customized roller dimensions and materials
- Customized distance between outside guide rollers
- Special calibration using customer supplied material

The Operating Instructions can also be used for these instruments as their handling is the same.

Model Numbers:

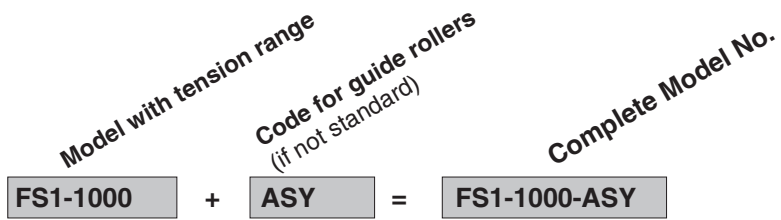

2.1.1 Available FS1 Models

Model	Tension Ranges [cN]	*Measuring Head Width [mm]	**Schmidt Calibration Material
FS1-50	0 - 50	64	PA: 0.12 mm Ø
FS1-100	0 - 100	64	PA: 0.12 mm Ø
FS1-200	0 - 200	64	PA: 0.12 mm Ø
FS1-500	0 - 500	64	PA: 0.20 mm Ø
FS1-1000	0 - 1000	64	PA: 0.30 mm Ø
FS1-2000	0 - 2000	124	PA: 0.50 mm Ø
FS1-5000	0 - 5000	124	PA: 0.80 mm Ø
FS1-10K	0 - 10 daN	124	PA: 1.00 mm Ø
FS1-20K	0 - 20 daN	224	PA: 1.50 mm Ø
FS1-50K	0 - 50 daN	224	Steel rope: 1.5mm Ø (7 x 7 x 0.20)



FS1 Guide Rollers:

V-Groove	Line Speed [m/min ... max.]	Roller Material
Standard	2000	Hardcoated aluminium
Code K	3500	Hardcoated aluminium
Code H	5000	Plasma-coated aluminium (FS1-100 and higher ranges)
Code ST	1000	Hardened steel
Code B	1000	Tempered steel, specially for measuring tire cord
Code CE2	1000	Ceramic
Asymmetrical Groove Code ASY	1000	Hardcoated aluminium (FS1-500 and higher ranges)
Code ASYB	1000	Tempered Steel (FS1-500 and higher ranges)
U-Groove Code U	2000	Hardcoated aluminium (FS1-500 and higher ranges)

* Outer dimensions of front plate.

** Suitable for 95% of applications. PA = Polyamide Monofilament
Should the process material differ significant from the SCHMIDT calibration material in size, rigidity or shape, we recommend special calibration using customer supplied material.

International unit of tensile force: 1 cN = 1.02 g = 0.01 N
 1 daN = 1.02 kg = 10.00 N

2.1.2 Available FSP Models



Model	Tension Ranges [cN]	*Measuring Head Width [mm]	**Schmidt Calibration Material
FSP-50	0 - 50	64	PA: 0.12 mm Ø
FSP-100	0 - 100	64	PA: 0.12 mm Ø
FSP-200	0 - 200	64	PA: 0.12 mm Ø
FSP-500	0 - 500	64	PA: 0.20 mm Ø
FSP-1000	0 - 1000	64	PA: 0.30 mm Ø

FSP Guide Rollers:

Ceramic Pins	Line Speed [m/min ... max.]	Pin Material
Standard	2000	Aluminium-oxid ceramic 5.2 mm Ø

2.1.3 Available FSH Models



Model	Tension Ranges [cN]	*Measuring Head Width [mm]	**Schmidt Calibration Material
FSH-1000	0 - 1000	150	PA: 0.30 mm Ø
FSH-2000	0 - 2000	150	PA: 0.50 mm Ø
FSH-5000	0 - 5000	200	PA: 0.80 mm Ø
FSH-10K	0 - 10 daN	200	PA: 1.00 mm Ø
FSH-20K	0 - 20 daN	250	PA: 1.50 mm Ø
FSH-50K	0 - 50 daN	250	Steel rope: 1.5 mm Ø (7 x 7 x 0.20)
FSH-100K	0 - 100 daN	250	Steel rope: 3.0 mm Ø (6 x 7 x 0.30)

FSH Guide Rollers:

V-Groove	Line Speed [m/min ... max.]	Roller Material
Standard	4000	Hardened steel (max. 4 mm Ø)
U-Groove Code R1	4000	Hard chrome plated steel (3 - 9 mm Ø)
Code R4	1000	Hardened steel (8 - 11 mm Ø) Model FSH-50K and higher
Code R5	1000	Hardened steel (11 - 15 mm Ø) Model FSH-50K and higher
flat Code B6	2000	Hardened steel, width 6 mm
Code B10	2000	Hardened steel, width 10 mm

* Outer dimensions of front plate.

** Suitable for 95% of applications. PA = Polyamide Monofilament

Should the process material differ significant from the SCHMIDT calibration material in size, rigidity or shape, we recommend special calibration using customer supplied material.

International unit of tensile force:

1 cN = 1.02 g = 0.01 N

1 daN = 1.02 kg = 10.00 N

2.1.4 Available FSW Models



Model with Tension Range	Tension Ranges [daN]	*Measuring Head Width [mm]	**Schmidt Calibration Material
FSW-20K	0 - 20	550	Steel rope: 1.5 mm Ø (7 x 7 x 0.25)
FSW-50K	0 - 50	550	Steel rope: 3 mm Ø (6 x 7 x 0.30)
FSW-100K	0 - 100	550	Steel rope: 4 mm Ø (6 x 7 x 0.50)
FSW-200K	0 - 200	550	Steel rope: 4 mm Ø (6 x 7 x 0.50)

FSW Guide Rollers:

V-Groove	Line Speed [m/min ... max.]	Roller Material
Standard	2000	Hard-coated aluminium max. wire diameter 5 mm
U-Groove Code R2	2000	Hard-coated aluminium (radius R 5)
Code R3	2000	Hard-coated aluminium (radius R8)

2.1.5 Available FSL Models



Model	Tension Ranges [cN]	*Measuring Head Width [mm]	**Schmidt Calibration Material
FSL-50	0 - 50	150	PA: 0.12 mm Ø
FSL-100	0 - 100	150	PA: 0.12 mm Ø
FSL-200	0 - 200	150	PA: 0.12 mm Ø
FSL-500	0 - 500	150	PA: 0.20 mm Ø
FSL-1000	0 - 1000	150	PA: 0.30 mm Ø

FSL Guide Rollers:

V-Groove	Line Speed [m/min ... max.]	Roller Material
Standard	4000	Hardcoated aluminium
Code T	4000	Plastic (PVC red) (same dimensions as standard roller)

* Outer dimensions of front plate.

** Suitable for 95% of applications. PA = Polyamide Monofilament

Should the process material differ significant from the SCHMIDT calibration material in size, rigidity or shape, we recommend special calibration using customer supplied material.

International unit of tensile force: 1 cN = 1.02 g = 0.01 N

1 daN = 1.02 kg = 10.00 N

2.1.6 Available FSB1 Models

Model	Tension Ranges [cN]	*Measuring Head Width [mm]	Roller Widths [mm]
FSB1-100	0 - 100	60	7, 10, 15, 20
FSB1-200	0 - 200	60	7, 10, 15, 20
FSB1-500	0 - 500	60	7, 10, 15, 20
FSB1-1000	0 - 1000	60	7, 10, 15, 20, 30
FSB1-2000	0 - 2000	120	7, 10, 15, 20, 30
FSB1-5000	0 - 5000	120	7, 10, 15, 20, 30
FSB1-10K	0 - 10K	120	7, 10, 15, 20
FSB1-20K	0 - 20K	120	7, 10, 15, 20



FSB1 Guide Rollers:

V-Groove	Line Speed [m/min ... max.]	Roller Material
Standard	1000	Hardcoated aluminium

* Outer dimensions of front plate.

International unit of tensile force:

$$1 \text{ cN} = 1.02 \text{ g} = 0.01 \text{ N}$$

$$1 \text{ daN} = 1.02 \text{ kg} = 10.00 \text{ N}$$

2.2 Specifications of the FS Series

Calibration: According to SCHMIDT factory procedure

Accuracy: For 10% to 100% of range: $\pm 1.5\%$ FS*

Other calibration material: $\pm 3\%$ FS* or better

Overload Protection: 100% of range

Measuring Principle: Strain gauge bridge

Meas. Roller Deflection: 0.5 mm, max.

Natural Frequency of

Measuring Spring: Approx. 500 Hz, depending on tension range

Signal Processing: Analog

Output Signal: 0 - 1 V DC, impedance: $\geq 5 \text{ k}\Omega$ (standard)

Option Code **A2:** 0 - 10 V DC

Option Code **A3:** 4 - 20 mA

Damping (f_d): Standard: approx. 30 Hz (other values on request)

Temperature Coefficient: Up to FS1-200: Zero point less than $\pm 0.2\%$ FS* / °C

From FS1-500: Zero point: less than $\pm 0.05\%$ FS* / °C

Temperature Range: 10 - 45 °C

Air Humidity: 85% RH, max.

Power Supply: 15 to 24 V DC, 21mA (regulated)

Option code A3: max. 50 mA

Housing: Aluminium

*Full Scale

2.3 Assignment of the Connector

i To assure immunity to random noise, the measuring head must be installed in such a way that it is insulated from ground (GND). The shield of the connecting cable must be connected to the metal housing of the connecting plug.

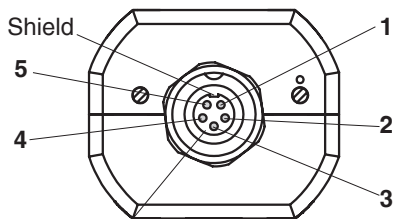

fig. 2.3a

Female socket M9 (series 712 - company Binder)

Pin assignment when viewed from outside:

- 1 - Vcc + 15 to 24 V DC regulated
- 2 - Ground
- 3 - Ground
- 4 - Signal output -
- 5 - Signal output +

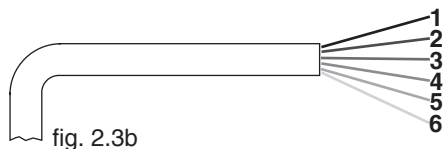

fig. 2.3b

Strand assignment of cable EK0620:

- 1 (white) - Vcc + 15 to 24 V DC regulated
- 2 (brown) - Ground
- 3 (black) - Ground
- 4 (blue) - Signal output -
- 5 (grey) - Signal output +
- 6 - Shield

2.3.1 Connecting the Tension Meter

CE The requirements of the CE specification are only complied with if the tension sensor is equipped and operated with display units and connecting cables supplied by HANS SCHMIDT & Co GmbH. Certification to the CE specification does not extend to, and shall be invalid for any other combination. Under no circumstances shall HANS SCHMIDT & Co GmbH be held liable for any damage resulting from the use of non-SCHMIDT sensors or cables.

2.4 Optional Accessories

Code **A2**: Analog output 0 - 10 V DC

Code **A3**: Analog output 4 - 20 mA

E10070 M9 sub-miniatur connector (series 712 - company Binder)

E10071 M9 sub-miniatur right angle plug (series 712 - company Binder)

EK0620 Connecting cable M9 sub-miniatur connector and open ends. Length 2 m

EK0621 Connecting cable M9 sub-miniatur connector and open ends. Length 5 m

EK0622 Connecting cable M9 sub-miniatur right angle plug and open ends. Length 2 m

EK0623 Connecting cable M9 sub-miniatur right angle plug and open ends. Length 5 m

EK0624 Connecting cable M9 sub-miniatur connector and 8-pin diode plug. Length 2 m

2.5 Delivery Includes

- 1 Sensor
- 1 Operating Instructions

2.6 Unpacking

Unpack the instrument and inspect it for any shipping damage. Notices of defect must be announced immediately, in writing, at the latest within 7 days on receipt of the goods.

3 Operating Procedure



Tensions that exceed the tension range of the instrument by more than 100% may cause permanent damage to the measuring spring and must be avoided under any circumstances.

CE conformity testing was carried out and successfully passed by Hans Schmidt & Co GmbH with a complete unit consisting of: FS sensor, SCD-1, display unit and an 5 m long connecting cable (special cable).

In no event shall HANS SCHMIDT & Co GmbH take over any warranty coverage for, or shall be held liable for, any damage resulting from self-made cables.



The model number, the serial number, the calibration label (option) and the SCHMIDT Quality Seal are provided on the cylindrical portion of the sensor.

3.1 Mounting possibilities

Sensors of FS series can be mounted in different ways:

- Mounting by using the frontplate on a cylindrical hole (cut out 38.5 - 40 mm Ø)
- Mounting on a flat platform

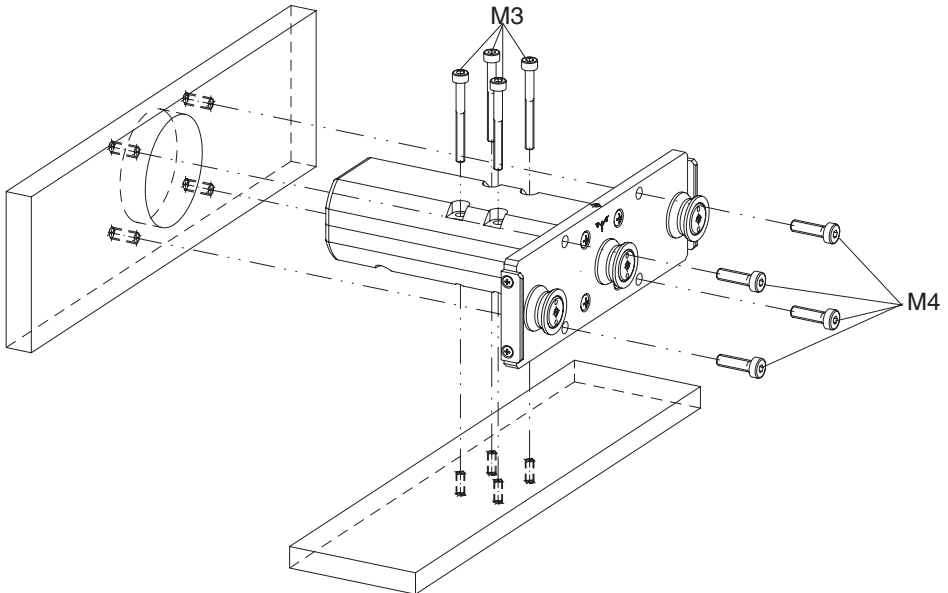

3.2 Initial Setup

- Install the sensor at the desired measuring location.
- Connect the sensor to the supplied or existing display unit.
The pin assignment of the 5-pin connector located on the rear side of the sensor is described in Chapter 2.3
- If the material path is other than vertical or if the process material deviates significantly from the SCHMIDT calibration material, you need to carry out zero adjustment and gain adjustment as described in Chapters 3.3.1 and 3.3.2 before starting measurement.
- Allow approx. 10 minutes for thermal stabilization of the sensor.
- Thread the process material through the measuring and guide rollers, following the material path symbol on the front of the sensor.

3.3 Internal Adjustment of the Sensors

General information:

If the sensor has been delivered with a display unit, the ZERO and GAIN adjustments should only be carried out with the supplied display unit.

All tension meters are calibrated with standard materials - such as polyamide monofilament (PA) - according to the SCHMIDT factory procedure; the material path is vertical.

Any difference in process material size and rigidity from the standard material may cause a deviation of the accuracy.

In 95% of all industrial applications the SCHMIDT calibration has been proven to provide the best results and is used for comparative purposes.

If required you can also operate the sensors with a material path other than vertical. Should the process material differ significantly from the SCHMIDT calibration material in size, rigidity or shape, we recommend special calibration using customer supplied material. If the material path is other than vertical or if the process material deviates significantly from the SCHMIDT calibration material, you need to carry out static **ZERO** and **GAIN adjustment** as described in Chapters 3.3.1 and 3.3.2.

3.3.1 ZERO Adjustment

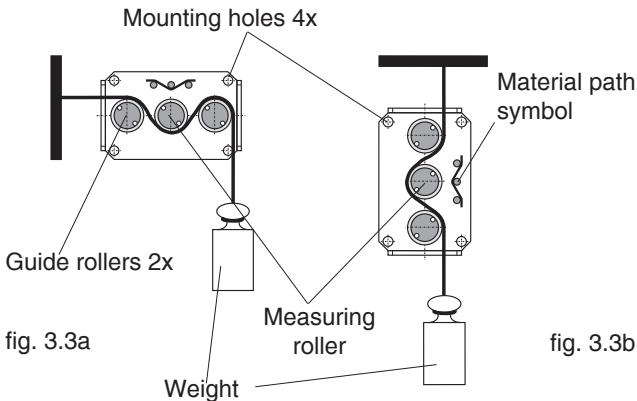

fig. 3.3a

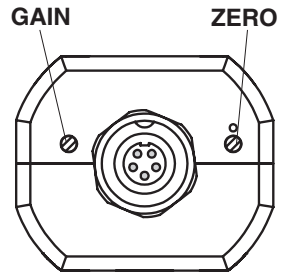

fig. 3.3b

fig. 3.3c

3.3.1 ZERO Adjustment (Cont.)

- Install the sensor in the desired position at the measuring location using the provided mounting holes.
- Allow approx. 10 minutes for thermal stabilization of the sensor.
- Thread the process material through the measuring and guide rollers, following the material path symbol on the front of the sensor.



When threading the process material through the rollers, follow the material path symbol on the front of the sensor. If a force is applied to the middle sensor roller in the incorrect direction, damage could result.



Since ZERO and GAIN adjustments are always performed statically, the readings may differ under dynamic load.

- Hang a weight that corresponds to e.g. 10% of the tension range from the process material.
- Connect a volt meter to pins 4 and 5 of the connector on the rear side of the unit.
- Adjust the potentiometer, which you can reach through the ZERO hole in the housing, with a screwdriver (with a point width of max. 1.9 mm) until the display of the connected volt meter reads,
for example:
Sensor model FS1 - 200:
Weight 20 cN = Display 0.100 V for the FS1 standard version
or
Weight 20 cN = Display 1.00 V for the FS1 version with 10 V output signal.



Do not insert the screwdriver at an angle as this may damage the potentiometer.

3.3.2 GAIN Adjustment

Requirement: ZERO adjustment carried out.

Thread the process material through the measuring and guide rollers, following the material path symbol on the front of the sensor.

- Hang a weight that corresponds to e.g. 95% of the tension range from the process material.
- Adjust the potentiometer, which you can reach through the GAIN hole in the housing, with a screwdriver (with a point width of max. 1.9 mm) until the display of the connected volt meter reads,
for example:
Sensor model FS1 - 200:
Weight 190 cN = Display 0.950 V for FS1 standard version
or
Weight 190 cN = Display 9.50 V for FS1 version with 10 V output signal.



Do not insert the screwdriver at an angle as this may damage the potentiometer.

- Check the adjustments with a new filament of the process material and repeat the procedure, if required, as described in Chapters 3.3.1 and 3.3.2.

4 Service and Maintenance

The tension meter is easy to maintain. Depending on operating time and load, the instrument should be checked according to the locally valid regulations and conditions (as described in Chapter 3.3). The use of other test methods than the procedure described in Chapter 3.3 may cause deviating measuring results.

4.1 Rollers

You should regularly inspect the rollers to assure that they are running easily and smoothly. You can replace the rollers yourself, as necessary. Please indicate the tension meter model and the serial number in your spare-parts order.

5 Cleaning

For cleaning the unit, do not use any



AGGRESSIVE SOLVENTS

such as trichloroethylene or similar chemicals.



NO WARRANTY OR LIABILITY

shall be accepted for damage resulting from improper cleaning.

6 Verification Interval

The question of finding the right frequency of calibration accuracy verification depends on several different factors:

- ➔ Operating time and load of the SCHMIDT tension meter
- ➔ Tolerance band defined by the customer
- ➔ Changes to the tolerance band compared to previous calibrations

Therefore, the interval between verifications of calibration must be determined by the user's Quality Assurance Department, based on the user's experience.

Assuming normal operating time and load as well as careful handling of the tension meter, we recommend a verification interval of one year.

6.1 Verification of Calibration and Determination of Repair Costs

Flow chart for verifying the calibration of used tension meters, incoming and outgoing verification with Inspection Certificate 3.1 according to DIN EN 10204

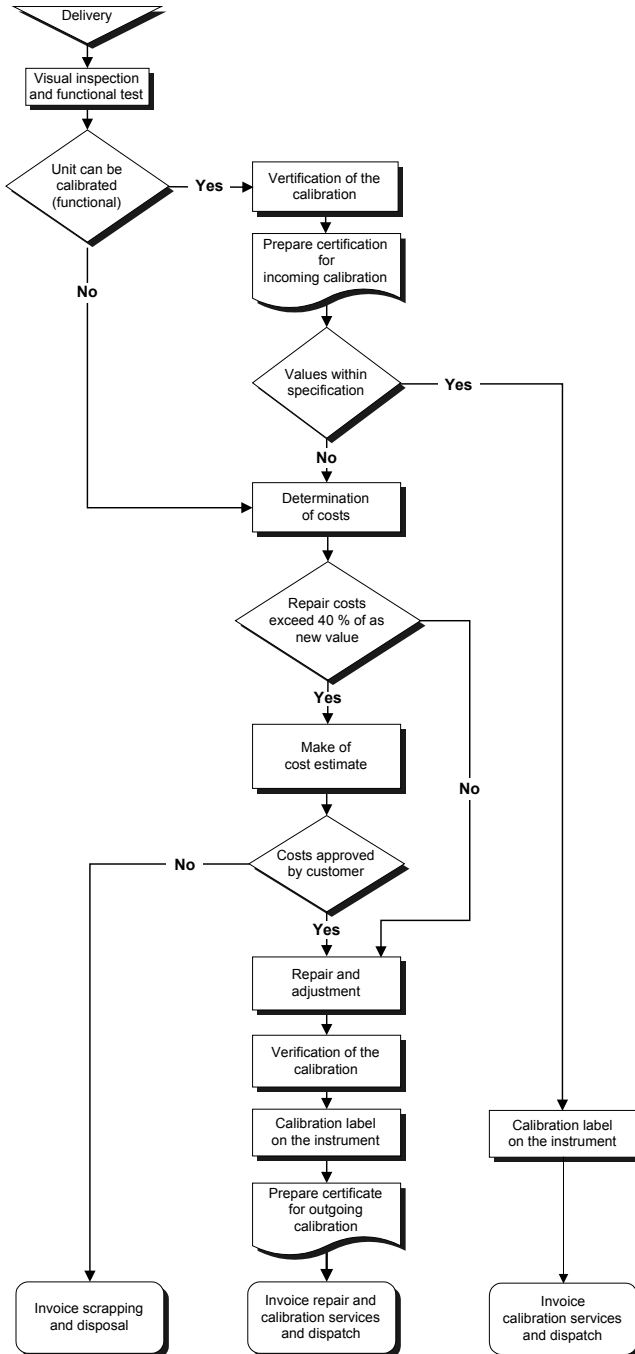

7 Correspondence

Should you have any questions regarding the instrument or Operating Instructions, or their use, please indicate above all the following details which are given on the ID plate:

- 1) Model
- 2) Serial number

8 Repairs

Shipping instructions:

We kindly ask for return free of charge for us, if possible by airmail parcel. All occurring charges, if any (such as freight, customs clearance, duty etc.), will be billed to customer. For return from foreign countries, we ask you to include a proforma invoice with a low value for customs clearance only, e.g. 50 Euro, each and to advise the shipment in advance by fax or eMail.

i To avoid unnecessary follow-up questions, and the resulting loss of time or possible misunderstandings, please return the instrument with a detailed fault description to our service department. Please indicate in your order whether you require an Inspection Certificate 3.1 according to DIN EN 10204.

Service address:

**HANS SCHMIDT & Co GmbH
Schichtstr. 16
84478 Waldkraiburg
Germany**

Subject to change without notice!

Notes:

More than 70 years - Worldwide -

Hans Schmidt & Co GmbH

Mailing address:

P. O. B. 1154
84464 Waldkraiburg Germany

Shipping address:

Schichtstr. 16
84478 Waldkraiburg Germany

Phone:

int. + 49 / (0)8638 / 9410-0

Fax:

int. + 49 / (0)8638 / 4825

int. + 49 / (0)8638 / 67898

e-mail:

info@hans-schmidt.com

Internet:

http://www.hans-schmidt.com