

Tension Meter

SCHMIDT
control instruments



Edition FSR 01.E

FS Series

Model FSR

Instruction Manual

Valid as of: 01.09.2017 • Please keep the manual for future reference!

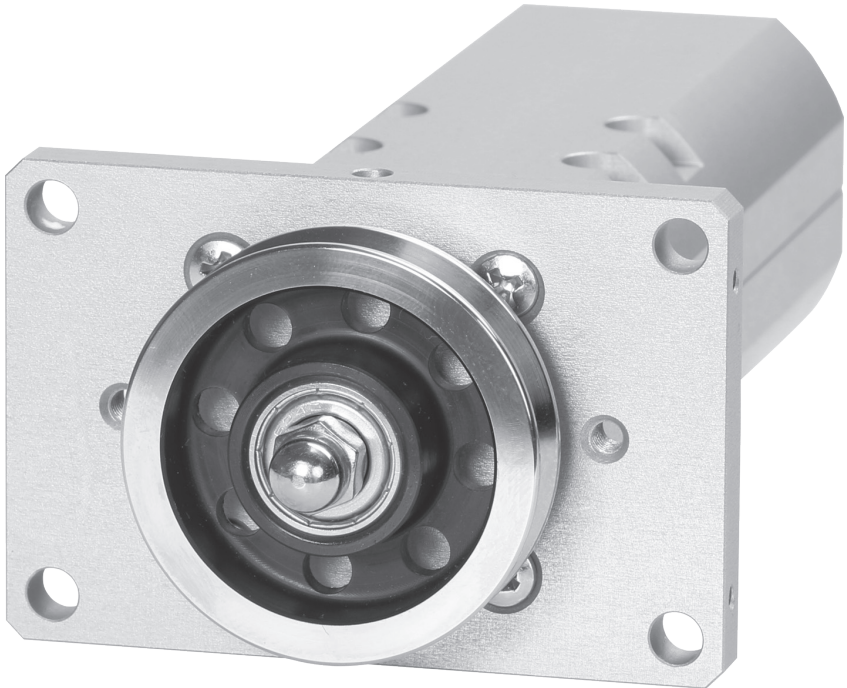

SCHMIDT · 1ST IN TENSIONMETERS WORLDWIDE

Contents

1	Warranty and Liability	3
1.1	Notices within the Operating Instructions	3
1.2	Responsibilities of the Operating Company	3
1.3	Responsibilities of the Personnel	3
1.4	Informal Safety Measures	4
1.5	Training of the Personnel	4
1.6	Intended Use	4
1.7	Dangers in Handling the Device	4
1.8	Copyright	4
1.9	Declaration of Conformity, RoHs II and WEEE Registration	4
2	Available Models	5
2.1	General Information	5
2.2	Specifications of the FS Series	5
2.3	Assignment of the Connector	6
2.3.1	Connecting the Tension Meter	6
2.4	Optional Accessories	6
2.5	Delivery Includes	6
2.6	Unpacking	7
3	Operating Procedure	7
3.1	Mounting possibilities	7
3.2	Initial Setup	8
3.3	Determining the tension range	8
3.4	Internal Adjustment of the Sensors	9
3.4.1	ZERO Adjustment	9
3.4.2	GAIN Adjustment	10
4	Service and Maintenance	11
4.1	Rollers	11
5	Cleaning	11
6	Verification Interval	11
7	Correspondence	11
8	Repairs	12

1 Warranty and Liability

In principle, the supply of the device is subject to our “General Conditions of Sale and Delivery.” These have been provided to the operating company on conclusion of the contract, at the latest.

Warranty:

- SCHMIDT tension meters are warranted for 12 months.

Parts subject to wear, electronic components and measuring springs are not covered by the warranty. No warranty or liability will be accepted for bodily injury or property damage resulting from one or several of the following causes:

- Misuse or abuse of the device.
- Improper mounting, commissioning, operation and maintenance of the device (e.g. verification interval).
- Operation of the device if any safeguards are defective or if any safety and protection precautions are not properly installed or not operative.
- Failure to comply with the notices in the Operating Instructions regarding transport, storage, mounting, commissioning, operation, maintenance and setup of the device.
- Any unauthorized structural alteration of the device.
- Insufficient inspection of device components that are subject to wear.
- Opening the device or improper repair work.
- Disasters caused by the effects of foreign objects or by force majeure.

1.1 Notices within the Operating Instructions

The fundamental prerequisite for the safe handling of this device and its troublefree operation is the knowledge of the basic safety notices and safety instructions.

These Operating Instructions contain the most important notices for the safe operation of the device.

These Operating Instructions, in particular the safety notices, must be observed by any person who works with the device. In addition, the local valid rules and regulations for the prevention of accidents must be complied with.

The representations within the Operating Instructions are not true to scale.

The dimensions given are not binding.

General indications of direction, such as FRONT, REAR, RIGHT, LEFT apply when viewing the front of the device.

1.2 Responsibilities of the Operating Company

In compliance with the EC Directive 89/655/EEC, the operating company agrees to only permit persons to work with the device who:

- are familiar with the basic regulations on industrial safety and accident prevention and who have been trained in handling the device.
- have read and understood the chapter on safety and the warning notices in these Operating Instructions and have confirmed this with their signatures.
- are examined regularly on their safe and conscientious working method.

1.3 Responsibilities of the Personnel

All persons who work with the device agree to perform the following duties before starting work:

- to observe the basic regulations on industrial safety and accident prevention.
- to read the chapter on safety and the warning notices in these Operating Instructions and to confirm with their signatures that they have understood them.

1.4 Informal Safety Measures

The Operating Instructions must always be kept on hand where the device is operated. Apart from the Operating Instructions, the general and local valid regulations on accident prevention and environmental protection must be provided and complied with.

1.5 Training of the Personnel

Only trained and instructed personnel is permitted to work with the device. The responsibilities of the personnel must be clearly defined for mounting, commissioning, operation, setup, maintenance, and repair. Trainees may only work with the device under the supervision of experienced personnel.

1.6 Intended Use

The device is intended exclusively to be used as a tension meter. Any other use or any use exceeding this intention will be regarded as misuse. Under no circumstances shall HANS SCHMIDT & Co GmbH be held liable for damage resulting from misuse.

The intended use also includes:

- Complying with all notices included in the Operating Instructions and observing all inspection and maintenance works.

1.7 Dangers in Handling the Device

The device was designed according to the state of the art and the approved safety standards. Nevertheless, its use may cause serious or fatal injury to the user or third persons, and/or an impairment of the device or of other material assets.

The device may only be applied:

- For its intended use in a faultless condition with regard to the safety requirements.
- Malfunctions that could impair safety must be remedied immediately.
- Personal protective equipment must be used according to the EC Directive 89/686/EEC.



The device must not be operated in potential explosive areas and must not come into contact with aggressive substances.

1.8 Copyright

The copyright on these Operating Instructions remains with the company HANS SCHMIDT & Co GmbH.

These Operating Instructions are intended for the operating company and its personnel only. They contain instructions and notices that may only be reproduced on the prior written permission of

HANS SCHMIDT & Co GmbH

and under indication of the complete reference data.

Violations will be prosecuted.

1.9 Declaration of Conformity, RoHs II and WEEE Registration

In compliance with the EU Directives 2014/30/EU and 2011/65/EU



HANS SCHMIDT & CO GmbH is registered in compliance with the German Electrical and Electronic Equipment Act (ElektroG) under WEEE Reg. No. DE 48092317.

2 Available Models

2.1 General Information

These Operating Instructions refer to the FSR Model of the FS Series:

Model	Tension Ranges N
FSR-10N	0 - 10
FSR-20 N	0 - 20
FSR-50 N	0 - 50
FSR-100 N	0 - 100
FSR-200 N	0 - 200
FSR-500 N	0 - 500

Guide Rollers:

V-Groove	Line Speed m/min ... max.	Groove Ø in mm	Roller Material
Standard	4000	29.5	Hadened steel
Code R1	4000	29.5	Hard chrome-plated steel (radius R5)
Code F	4000	70	Hard-coated aluminium
Code FB	4000	70	Tempered steel
flat Code B6	2000	29.5	Hardened steel, width 6 mm
Code B10	2000	29.5	Hardened steel, width 10 mm

2.2 Specifications of the FS Series

Calibration:	According to SCHMIDT factory procedure
Accuracy:	For 10% to 100% of range: $\pm 1.5\%$ FS* Other calibration material: $\pm 3\%$ FS* or better
Overload Protection:	100% of range
Measuring Principle:	Strain gauge bridge
Meas. Roller Deflection:	0.5 mm, max.
Natural Frequency of	
Measuring Spring:	Approx. 500 Hz, depending on tension range
Signal Processing:	Analog
Output Signal:	0 - 1 V DC, impedance: ≥ 5 kOhm (standard)
Option Code A2:	0 - 10 V DC
Option Code A3:	4 - 20 mA
Damping (f_g):	Standard: approx. 30 Hz (other values on request)
Temperature Coefficient:	Zero point: less than $\pm 0.05\%$ FS* / °C
Temperature Range:	10 - 45 °C
Air Humidity:	85% RH, max.
Power Supply:	15 to 24 V DC (21mA) (regulated) Option code A3: max. 50 mA
Housing:	Aluminium
Weight:	Approx. 250 g

*Full Scale

2.3 Assignment of the Connector

- 1** To assure immunity to random noise, the measuring head must be installed in such a way that it is insulated from ground (GND).
The shield of the connecting cable must be connected to the metal housing of the connecting plug.

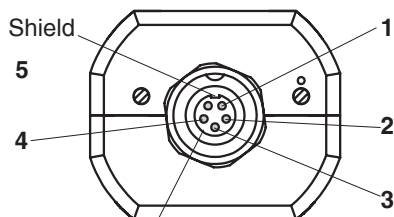

Pin assignment when viewed from outside:

- 1 - Vcc + 15 to 24 V DC regulated
- 2 - Ground
- 3 - Ground
- 4 - Signal output -
- 5 - Signal output +

fig. 2.3a

Female socket M9 (series 712 - company Binder)

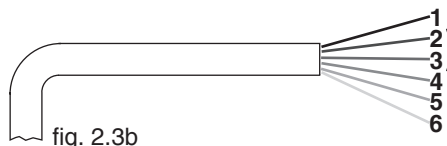

fig. 2.3b

Strand assignment of cable EK0620:

- 1 (white) - Vcc + 15 to 24 V DC regulated
- 2 (black) - Ground
- 3 (brown) - Ground
- 4 (blue) - Signal output -
- 5 (grey) - Signal output +
- 6 - Shield

2.3.1 Connecting the Tension Meter

- C** The requirements of the CE specification are only complied with if the tension sensor is equipped and operated with display units and connecting cables supplied by HANS SCHMIDT & Co GmbH. Certification to the CE specification does not extend to, and shall be invalid for any other combination. Under no circumstances shall HANS SCHMIDT & Co GmbH be held liable for any damage resulting from the use of non-SCHMIDT sensors or cables.

2.4 Optional Accessories

Code **A2**: Analog output 0 - 10 V DC

Code **A3**: Analog output 4 - 20 mA

E10070 M9 sub-miniatur connector (series 712 - company Binder)

E10071 M9 sub-miniatur right angle plug (series 712 - company Binder)

EK0612 Connecting cable M9 sub-miniatur connector and open ends. Length 2 m

EK0621 Connecting cable M9 sub-miniatur connector and open ends. Length 5 m

EK0622 Connecting cable M9 sub-miniatur right angle plug and open ends. Length 2 m

EK0623 Connecting cable M9 sub-miniatur right angle plug and open ends. Length 5 m

EK0624 Connecting cable M9 sub-miniatur connector and 8-pin diode plug. Length 2 m

2.5 Delivery Includes

Sensor

1 Operating Instruction

2.6 Unpacking

Unpack the instrument and inspect it for any shipping damage. Notices of defect must be announced immediately, in writing, at the latest within 7 days on receipt of the goods.

3 Operating Procedure



Tensions that exceed the tension range of the instrument by more than 100% may cause permanent damage to the measuring spring and must be avoided under any circumstances.

CE conformity testing was carried out and successfully passed by Hans Schmidt & Co GmbH with a complete unit consisting of: TSR sensor, SCD-1 display unit and an 5 m long connecting cable (special cable).

In no event shall HANS SCHMIDT & Co GmbH take over any warranty coverage for, or shall be held liable for, any damage resulting from self-made cables.



The model number, the serial number, the calibration label (option) and the SCHMIDT Quality Seal are provided on the cylindrical portion of the sensor.

3.1 Mounting possibilities

Sensors FSR can be mounted in different ways:

- Mounting by using the frontplate on a cylindrical hole (cut out 38.5 - 40 mm Ø)
- Mounting on a flat platform

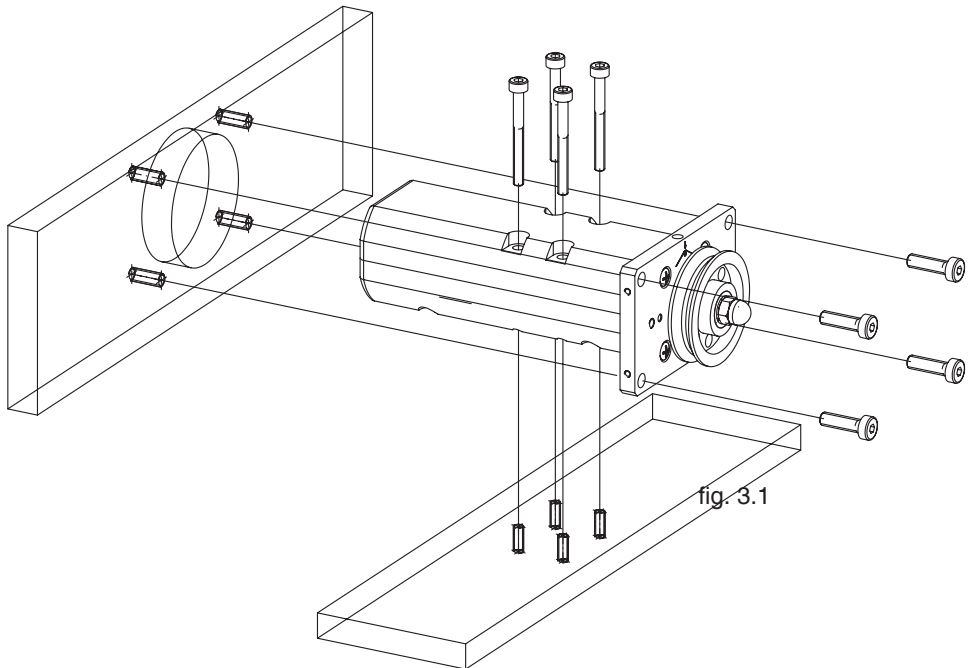

3.2 Initial Setup

- If the sensor is delivered with the standard roller, it is already mounted in the factory. If the device is supplied with a roller code F, FB, R1, B6 or B10, it must be installed. Tight the cap nut with 1 Nm.
- Install the sensor at the desired measuring location using the 4 provided mounting holes. To avoid damage of the load cell, the transmission of force has to occur in direction of the arrow. The direction of force is the angle bisector (fig.3.2).
- Connect the sensor to the supplied or existing display unit. The pin assignment of the 8-pin connector located on the rear side of the sensor is described in Chapter 2.3
- If the material path is other than vertical or if the process material deviates significantly from the SCHMIDT calibration material, you need to carry out zero adjustment and gain adjustment as described in Chapters 3.4.1 and 3.4.2 before starting measurement.
- Allow approx. 10 minutes for thermal stabilization of the sensor.
- Thread the process material through the measuring roller, following the arrow on the front of the sensor.

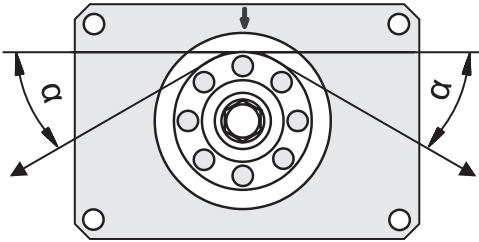
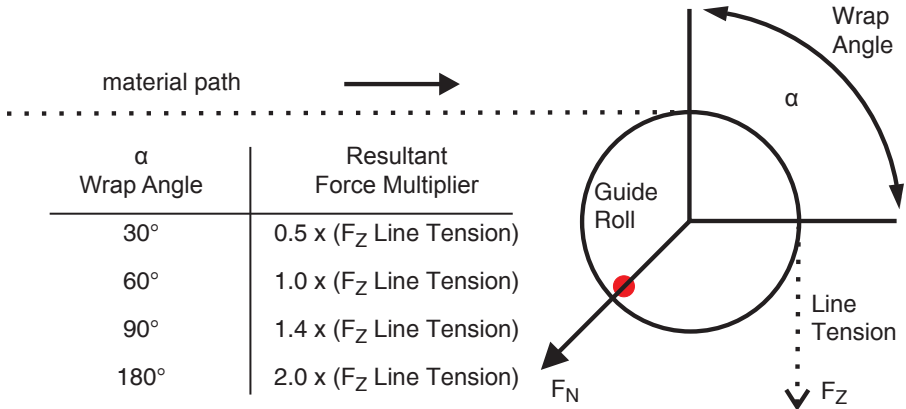

fig. 3.2

3.3 Determining the tension range



$$F_N = \text{Multiplier} \times F_Z$$

Recommended wrapping angle 40 - 180°

The tension range can be calculated for every wrapping angle with this formula:

3.3 Determining the tension range

F_N = Nominal load (Multiplier x F_Z)

F_Z = Line tension

α = Wrapping angle at the guide roll

$$F_N = 2 \cdot F_Z \cdot \sin \frac{\alpha}{2}$$



When selecting the nominal measurement force it is necessary to take into account the weight of the guide roll and raise the nominal load respectively, particularly when working with small nominal forces.

3.4 Internal Adjustment of the Sensors

General information:

All tension meters are calibrated with standard materials - such as polyamide monofilament (PA) - according to the SCHMIDT factory procedure; therefore the wrapping angle is 180°.



In any case you need to carry out static ZERO and GAIN adjustment as described in Chapters 3.4.1 and 3.4.2.

3.4.1 ZERO Adjustment

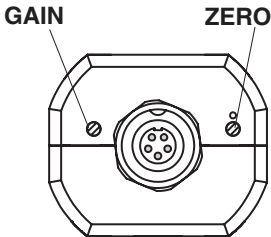

fig. 3.4.1a

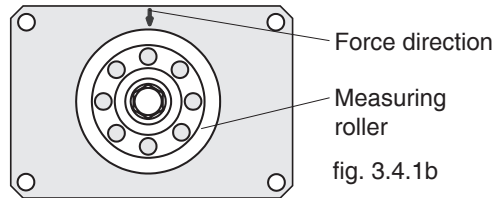

fig. 3.4.1b

- Install the sensor in the desired position at the measuring location using the provided mounting holes.
- Allow approx. 10 minutes for thermal stabilization of the sensor.



Since ZERO and GAIN adjustments are always performed statically, the readings may differ under dynamic load.

- Connect a volt meter to the yellow and green leads of the connecting cable
- Adjust the potentiometer, which you can reach through the ZERO hole in the housing, with a screwdriver (with a point width of max. 1.9 mm) until the display of the connected volt meter reads 0 cN = display 0 V,



Do not insert the screwdriver at an angle as this may damage the potentiometer.

3.4.2 GAIN Adjustment

Requirement: ZERO adjustment carried out.

Thread the process material in the measuring roller

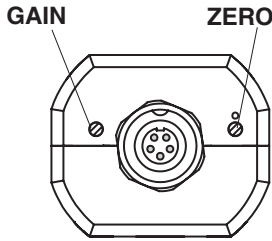

fig. 3.4.2a

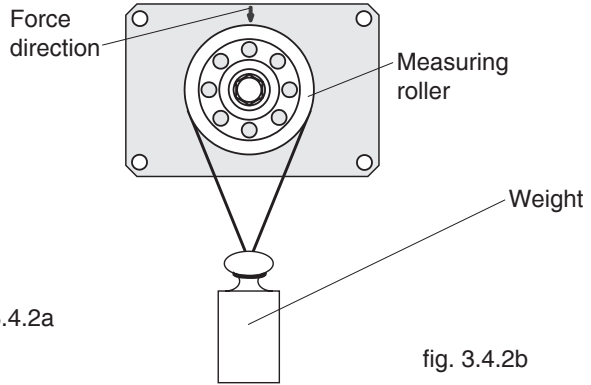

fig. 3.4.2b

- Hang a weight that corresponds 100% of the tension range from the process material.
- Adjust the potentiometer, which you can reach through the GAIN hole in the housing, with a screwdriver (with a point width of max. 1.9 mm) until the display of the connected volt meter reads, for example:
Sensor model FSR - 20N:
Weight 20 N = Displays 1 V for FSR standard version
or
Weight 20 N = Displays 100 V for FSR version with 10 V output signal.
- Check the adjustments with a new filament of the process material and repeat the procedure, if required, as described in Chapters 3.4.1 and 3.4.2.



Do not insert the screwdriver at an angle as this may damage the potentiometer.

Gain adjustment of sensors with output signal Code A10 has to be realized with display unit.

4 Service and Maintenance

The tension meter is easy to maintain. Depending on operating time and load, the instrument should be checked according to the locally valid regulations and conditions (as described in Chapter 3.4). The use of other test methods than the procedure described in Chapter 3.4 may cause deviating measuring results.

4.1 Rollers

You should regularly inspect the rollers to assure that they are running easily and smoothly. You can replace the rollers yourself, as necessary. Please indicate the tension meter model and the serial number in your spare-parts order.

5 Cleaning

For cleaning the unit, do not use any



AGGRESSIVE SOLVENTS

such as trichloroethylene or similar chemicals.



NO WARRANTY OR LIABILITY

shall be accepted for damage resulting from improper cleaning.

6 Verification Interval

The question of finding the right frequency of calibration accuracy verification depends on several different factors:

- ➔ Operating time and load of the SCHMIDT tension meter
- ➔ Tolerance band defined by the customer
- ➔ Changes to the tolerance band compared to previous calibrations

Therefore, the interval between verifications of calibration must be determined by the user's Quality Assurance Department, based on the user's experience.

Assuming normal operating time and load as well as careful handling of the tension meter, we recommend a verification interval of one year.

7 Correspondence

Should you have any questions regarding the instrument or Operating Instructions, or their use, please indicate above all the following details which are given on the ID plate:

- 1) Model
- 2) Serial number

8 Repairs

Shipping instructions:

We kindly ask for return free of charge for us, if possible by airmail parcel. All occurring charges, if any (such as freight, customs clearance, duty etc.), will be billed to customer. For return from foreign countries, we ask you to include a proforma invoice with a low value for customs clearance only, e.g. 50 Euro, each and to advise the shipment in advance by fax or eMail.

i To avoid unnecessary follow-up questions, and the resulting loss of time or possible misunderstandings, please return the instrument with a detailed fault description to our service department. Please indicate in your order whether you require an Inspection Certificate 3.1 according to DIN EN 10204.

Service address:

**HANS SCHMIDT & Co GmbH
Schichtstr. 16
84478 Waldkraiburg
Germany**

Subject to change without notice!

Notes:

More than 70 years - Worldwide -

Hans Schmidt & Co GmbH

Mailing address:

P. O. B. 1154
84464 Waldkraiburg Germany

Shipping address:

Schichtstr. 16
84478 Waldkraiburg Germany

Phone:

int. + 49 / (0)8638 / 9410-0

Fax:

int. + 49 / (0)8638 / 4825

int. + 49 / (0)8638 / 67898

e-mail:

info@hans-schmidt.com

Internet:

<http://www.hans-schmidt.com>