

Display Unit

**SCHMIDT**  
control instruments



Edition SC-PM 02.3.E

SC Series

Model SC-PM  
SC-PMD

# Instruction Manual

Valid as of: 01.01.2013 • Please keep the manual for future reference!

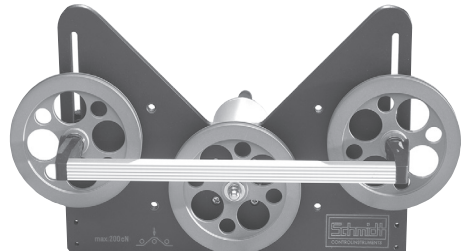
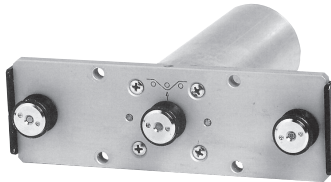
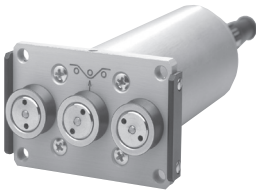
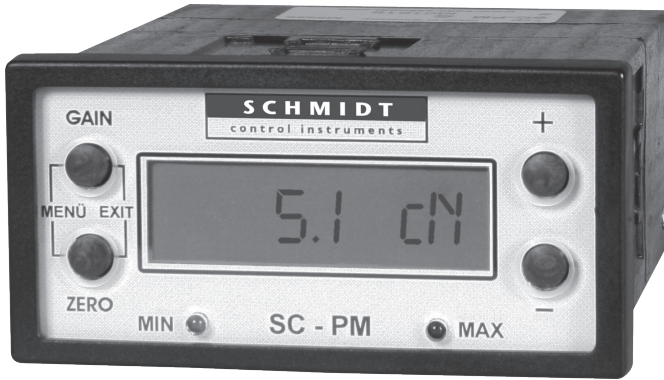

SCHMIDT · 1<sup>ST</sup> IN TENSIONMETERS WORLDWIDE

# Contents

<b>1</b>	<b>Warranty and Liability</b>	<b>3</b>
1.1	Notices within the Operating Instructions	3
1.2	Responsibilities of the Operating Company	3
1.3	Responsibilities of the Personnel	3
1.4	Informal Safety Measures	4
1.5	Training of the Personnel	4
1.6	Intended Use	4
1.7	Dangers in Handling the Device	4
1.8	Copyright	4
1.9	Declaration of Conformity, RoHS II and WEEE Registration	4
<b>2</b>	<b>General Information</b>	<b>5</b>
2.1	Specifications	5
2.2	Dimensions of the SC-PM	5
2.3	Pin Assignments of connectors and cable	6
2.3.1	Connecting the SC-PM	6
2.4	Delivery Includes	7
2.5	Optional Accessories	7
2.6	Unpacking	7
<b>3</b>	<b>Operation</b>	<b>8</b>
3.1	Operating Elements	8
3.1.1	Switch-On	8
3.1.2	Switch-Off	8
3.2	Operating Procedure	9
3.3	Settings	10
3.3.1	Changing the Settings	12
3.4	Sensor Calibration	17
3.4.1	ZERO and GAIN Adjustment	17
<b>4</b>	<b>Interfaces</b>	<b>19</b>
4.1	ANALOG Interface	19
4.1.1	ZERO and GAIN Adjustment of the ANALOG Interface	19
4.2	DIGITAL Interface	20
4.2.1	The TENSION INSPECT 3 Program	20
4.2.2	WINDOWS Terminal Program	20
<b>5</b>	<b>Online Sensor Specifications</b>	<b>21</b>
5.1	TS, FS and MZ Series	21
5.2	SF Series	21
<b>6</b>	<b>Service and Maintenance</b>	<b>22</b>
<b>7</b>	<b>Cleaning</b>	<b>22</b>
<b>8</b>	<b>Correspondence</b>	<b>22</b>
<b>9</b>	<b>Repairs</b>	<b>22</b>

## **1 Warranty and Liability**

In principle, the supply of the device is subject to our "General Conditions of Sale and Delivery." These have been provided to the operating company on conclusion of the contract, at the latest.

Warranty:

- SCHMIDT display units are warranted for 12 months.

Parts subject to wear, electronic components and measuring springs are not covered by the warranty. No warranty or liability will be accepted for bodily injury or property damage resulting from one or several of the following causes:

- Misuse or abuse of the device.
- Improper mounting, commissioning, operation and maintenance of the device (e.g. verification interval).
- Operation of the device if any safeguards are defective or if any safety and protection precautions are not properly installed or not operative.
- Failure to comply with the notices in the Operating Instructions regarding transport, storage, mounting, commissioning, operation, maintenance and setup of the device.
- Any unauthorized structural alteration of the device.
- Insufficient inspection of device components that are subject to wear.
- Opening the device or improper repair work.
- Disasters caused by the effects of foreign objects or by force majeure.

### **1.1 Notices within the Operating Instructions**

The fundamental prerequisite for the safe handling of this device and its troublefree operation is the knowledge of the basic safety notices and safety instructions.

These Operating Instructions contain the most important notices for the safe operation of the device.

These Operating Instructions, in particular the safety notices, must be observed by any person who works with the device. In addition, the local valid rules and regulations for the prevention of accidents must be complied with.

The representations within the Operating Instructions are not true to scale.

The dimensions given are not binding.

General indications of direction, such as FRONT, REAR, RIGHT, LEFT apply when viewing the front of the device.

### **1.2 Responsibilities of the Operating Company**

In compliance with the EC Directive 89/655/EEC, the operating company agrees to only permit persons to work with the device who:

- are familiar with the basic regulations on industrial safety and accident prevention and who have been trained in handling the device.
- have read and understood the chapter on safety and the warning notices in these Operating Instructions and have confirmed this with their signatures.
- are examined regularly on their safe and conscientious working method.

### **1.3 Responsibilities of the Personnel**

All persons who work with the device agree to perform the following duties before starting work:

- to observe the basic regulations on industrial safety and accident prevention.
- to read the chapter on safety and the warning notices in these Operating Instructions and to confirm with their signatures that they have understood them.

## 1.4 Informal Safety Measures

The Operating Instructions must always be kept on hand where the device is operated. Apart from the Operating Instructions, the general and local valid regulations on accident prevention and environmental protection must be provided and complied with.

## 1.5 Training of the Personnel

Only trained and instructed personnel is permitted to work with the device. The responsibilities of the personnel must be clearly defined for mounting, commissioning, operation, setup, maintenance, and repair. Trainees may only work with the device under the supervision of experienced personnel.

## 1.6 Intended Use

The device is intended exclusively for displaying tension values measured by the online sensors from HANS SCHMIDT & CO GMBH. Any use with sensors from other manufacturers or any use exceeding this intention will be regarded as misuse. Under no circumstances shall HANS SCHMIDT & Co GmbH be held liable for damage resulting from misuse.

The intended use also includes:

- Complying with all notices included in the Operating Instructions and observing all inspection and maintenance works.

## 1.7 Dangers in Handling the Device

The device was designed according to the state of the art and the approved safety standards. Nevertheless, its use may cause serious or fatal injury to the user or third persons, and/or an impairment of the device or of other material assets.

The device may only be applied:

- For its intended use in a faultless condition with regard to the safety requirements.
- Malfunctions that could impair safety must be remedied immediately.
- Personal protective equipment must be used according to the EC Directive 89/686/EEC.



**The device must not be operated in potential explosive areas and must not come into contact with aggressive substances.**

## 1.8 Copyright

The copyright on these Operating Instructions remains with the company HANS SCHMIDT & Co GmbH.

These Operating Instructions are intended for the operating company and its personnel only. They contain instructions and notices that may only be reproduced on the prior written permission of HANS SCHMIDT & Co GmbH and under indication of the complete reference data. Violations will be prosecuted.

## 1.9 Declaration of Conformity, RoHs II and WEEE Registration

In compliance with the EU Directives 2014/30/EU and 2011/65/EU



**HANS SCHMIDT & CO GmbH is registered in compliance with the German Electrical and Electronic Equipment Act (ElektroG) under WEEE Reg. No. DE 48092317.**

## 2 General Information

### 2.1 Specifications

<b>Digital Display:</b>	Dot matrix LCD, height of digit 12 mm with backlight
<b>Units of Measure:</b>	cN, daN, g, kg or lb (selectable)
<b>Damping (<math>f_g</math>):</b>	9-step adjustable
<b>Signal processing:</b>	Digital
<b>Output Signal:</b>	Analog signal: 0 - 10 V DC ( $R_{Load} \geq 5K \text{ Ohm}$ ) Update time 2 msec (500 Hz)
<b>Alarm Limits:</b>	High / Low (selectable), with output signal open collector max. 30 V DC, 10 mA
<b>Digital Output Signal (optional):</b>	RS-232 (19200, 8, N, 1) (approx 100 readings per sec.)
<b>Calibration</b>	3 characteristic curves can be saved
<b>Signal Input for Sensor:</b>	SC-PM: 0 - 1 V SC-PMD: mV/V
<b>Voltage Output for Sensor:</b>	SC-PM: 15 V SC-PMD: 3.3 V
<b>Power Supply:</b>	15 - 24 V DC
<b>Current Consumption:</b>	0.100 A
<b>Temperature Range:</b>	10 - 45° C
<b>Air Humidity:</b>	85% RH, max.
<b>Housing:</b>	Plastic
<b>Dimensions:</b>	115 x 95 x 48 mm
<b>Required Cutout:</b>	91.5 x 45 mm
<b>Weight, net (gross):</b>	Approx. 200 g (approx. 300 g)

### 2.2 Dimensions of the SC-PM

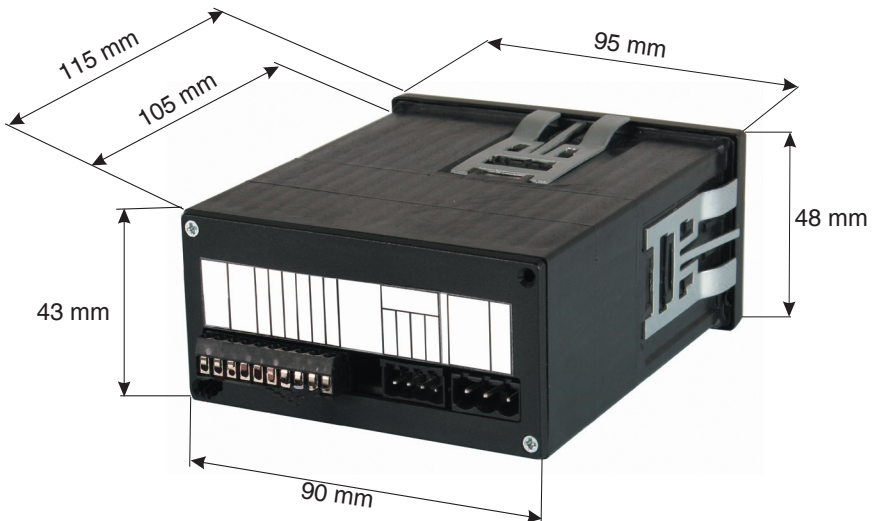

## 2.3 Pin Assignments of connectors and cable

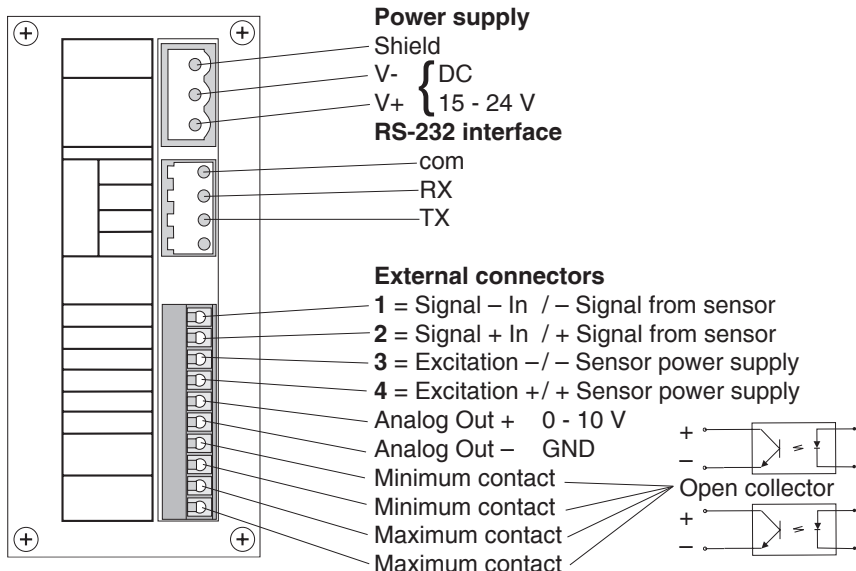

	TS Series	FS Series	MZ Series	SF Series
Signal - in [1]	white	blue	grey	green
Signal + in [2]	grey	grey	yellow	white
Excitation - [3]	rose	brown/black	brown	brown
Excitation + [4]	yellow	white	white	yellow

### 2.3.1 Connecting the SC-PM



The cable connecting the sensor with the display unit must be shielded. The shield of the connecting cable must be connected to the metal housing of the connecting plug.

Connect only sensors which comply with the specifications given in Chapter 5.

To avoid random noise and malfunctions, make sure the cable connecting the SC-PM with the sensor does not run parallel to power lines or highly loaded signal lines, regardless of the type of voltage.

**C E** The requirements of the CE specification are only complied with if the SC-PM is equipped and operated with sensors and connecting cables supplied by HANS SCHMIDT & Co GmbH. Certification to the CE specification does not extend to, and shall be invalid for any other combination. Under no circumstances shall HANS SCHMIDT & Co GmbH be held liable for any damage resulting from the use of non-SCHMIDT sensors or cables.

### 2.3.1 Connecting the SC-PM (Cont.)

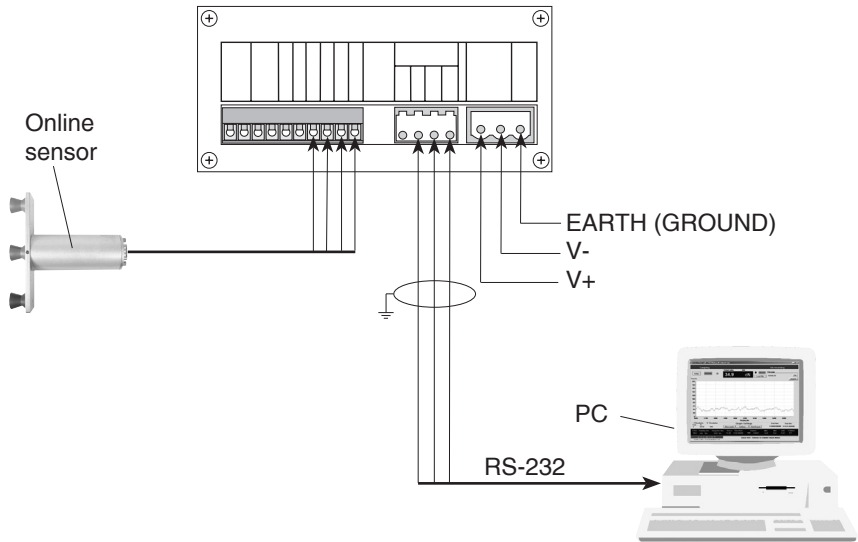

### 2.4 Delivery Includes

- SC-PM display unit
- 1 Operating Instructions
- 2 Alligator clips (3- and 10 pole)

### 2.5 Optional Accessories

SC-PM-232: RS-232 interface

SC-PM-A3 Current output 4 - 20 mA (0 - 10 V analog signal not applicable)

All options must be factory fitted, re-fitting is only possible at the manufacturer's facility.

- EK0612 Connecting cable for TS sensor with 1 diode plug and open ends, length 3 m
- EK0614 Connecting cable for TS sensor with 1 diode plug and open ends, length 5 m
- EK0615 Connecting cable for TS sensor with 1 diode plug and open ends, length 10 m
- EK0620 Connecting cable for FS sensor with 1 sub-miniatur connector and open ends, length 2 m
- EK0621 Connecting cable for FS sensor with 1 sub-miniatur connector and open ends, length 5 m
- EK0622 Connecting cable for FS sensor with 1 sub-miniatur angle connector and open ends, length 2 m
- EK0623 Connecting cable for FS sensor with 1 sub-miniatur angle connector and open ends, length 5 m
- EK0660 Connecting cable for RS-232 interface for connection to PC, length 2 m
- SW-TI3 Software »Tension Inspect 3« for displaying and saving readings on a PC (Win XP and higher)

### 2.6 Unpacking

Unpack the display unit and inspect it for any shipping damage. Notices of defect must be announced immediately, in writing, at the latest within 7 days on receipt of the goods.

### 3 Operation

#### 3.1 Operating Elements

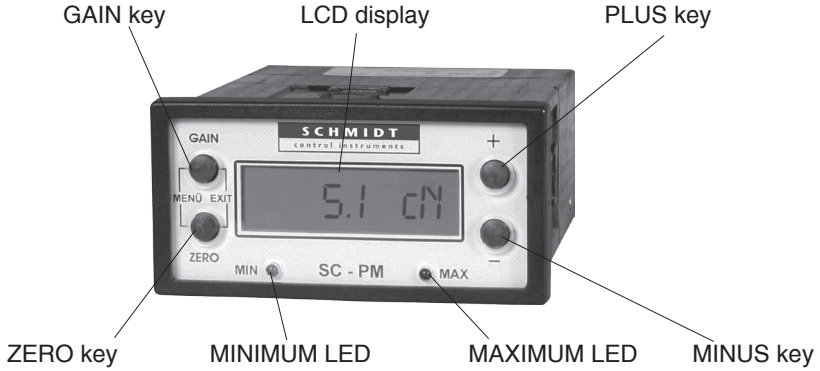

##### 3.1.1 Switch-On

###### Requirements:

- Install the sensor at the desired measuring location.
- Connect the external power supply.
- Connect the SC-PM to the supplied sensor with one of the optional available cables.



**In no event shall HANS SCHMIDT & Co GmbH take over any warranty coverage for, or shall be held liable for, any damage resulting from self-made cables.**

###### To switch on the SC-PM:

- Switch on the external power supply.

The LCD successively shows:

**SC-PM v1** the version number, **Rg 200.0** the set tension range,

**DAMP: 04** the set damping factor, and **CAL: 1** the set calibration curve.

It then changes to measuring mode.

The LCD shows **0.0 cN**.

##### 3.1.2 Switch-Off

- Switch off the external power supply.



## 3.2 Operating Procedure



Have you read and understood the Operating Instructions, in particular Chapter 1 “Basic Safety Notices”? You are not permitted to operate the device before doing so.

Before working with the device you must put on your personal protective clothing, if necessary. For example, eye protectors, gloves, etc.



The ID plate with the CE mark and the serial number as well as the calibration label (optional) and the SCHMIDT Quality Seal are provided on the surface of the instrument.

- Switch on the instrument as described in Chapter 3.1.1.
- Select the desired tension range as described in Chapter 3.3.1. (Only necessary when using the unit for the first time or after a sensor change.)
- Allow approx. 10 minutes for thermal stabilization of the instrument.
- If the material path is other than vertical or if the process material deviates significantly from the SCHMIDT calibration material, you need to carry out **ZERO** and **GAIN adjustment** as described in Chapter 3.4.1 before starting measurement.
- Thread the process material through the measuring and guide rollers, following the red material path symbol on the front of the sensor.

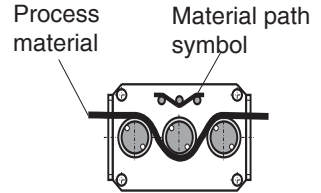

The LCD now shows 39.5 cN the measured line tension.



If the line tension drops below the low alarm limit set according to Chapter 3.3.1, the **MINIMUM LED** is lit.

If the line tension exceeds the high alarm limit set according to Chapter 3.3.1, the **MAXIMUM LED** is lit.

### 3.3 Settings

#### General Information:

The defaults for the display unit have been set to match the supplied sensor.  
The following default settings will apply to a sensor with a tension range up to 200.0 cN, for example:

- |                       |           |
|-----------------------|-----------|
| 1) Damping:           | DAMP: 04  |
| 2) Calibration curve: | CAL: 1    |
| 3) Alarm function:    | Alarm OFF |
| 4) High alarm limit:  | Max 180.0 |
| 5) Low alarm limit:   | Max 20.0  |
| 6) Tension range:     | Rg 200.0  |
| 7) Unit of measure:   | Unit cN   |
| 8) Analog ZERO:       | Anl.ZERO  |
| 9) Analog GAIN:       | Anl. GAIN |
| 10) Channel selection | CHAN: 00  |

 The settings you made remain stored in the SC-PM memory even after the instrument is switched off.

You can adapt these settings to your specific requirements.

#### Requirement:

- Instrument switched on as described in Chapter 3.1.1.

#### To change the settings:

- Simultaneously press and then release the GAIN and ZERO keys.

The LCD shows MENU and then DAMP: 04 .

### 3.3 Settings (Cont.)

By pressing the GAIN or ZERO key, you can now go to the individual settings for:

- |                       |           |   |
|-----------------------|-----------|---|
| 1) Damping:           | DAMP: 04  | ← |
| 2) Calibration curve: | CAL: 1    |   |
| 3) Alarm function:    | Alarm OFF |   |
| 4) High alarm limit:  | Max 180.0 |   |
| 5) Low alarm limit:   | Max 20.0  |   |
| 6) Tension range:     | Rg 200.0  |   |
| 7) Unit of measure:   | Unit cN   |   |
| 8) Analog ZERO:       | Anl.ZERO  |   |
| 9) Analog GAIN:       | Anl. GAIN |   |
| 10) Channel selection | CHAN: 00  | → |



**The CHAN (channel selection) setting must always be 00.  
Do not change this setting.**

- Press the GAIN or ZERO key to go to a different setting.

- Press the + or - key to set the desired value for the selected setting.

**OR**

- Simultaneously press and then release the GAIN and ZERO keys.

The display shows EXIT and the settings are saved.

The instrument then changes back to measuring mode.

The display shows 0.0 cN .

### 3.3.1 Changing the Settings

#### Requirement:

- Instrument switched on as described in Chapter 3.1.1.

#### To change the settings:

- Simultaneously press and then release the GAIN and ZERO keys.

The LCD shows  and then .

#### Calculation of the damping factor:

The instrument is factory-set to a damping factor of .

The tension values are thereby averaged in the following way for display on the LCD:

$$\frac{4 \text{ old values} + 5 \text{ new values}}{9}$$

9

The damping factor can be modified in 9 steps from 01 = low damping:

$$\frac{1 \text{ old value} + 8 \text{ new values}}{9}$$

9

to 09 = high damping:

$$\frac{8 \text{ old values} + 1 \text{ new value}}{9}$$

9

 **The settings you made remain stored in the SC-PM memory even after the instrument is switched off.**

- Press the + or – key to set the desired damping factor.

For example:

- Simultaneously press and then release the GAIN and ZERO keys.

The display shows  and the settings are saved.

The instrument then changes back to measuring mode.

The display shows .

#### OR

- Press the ZERO key to change the setting for the:

#### Calibration

Should the process material differ significantly from the SCHMIDT calibration material in size, rigidity or shape, we recommend special calibration using customer supplied material. If a different material path (e.g. horizontal) or special calibration using customer supplied material is required, you need to carry out static **ZERO** and **GAIN adjustment** as described in Chapter 3.4.1.

The instrument is factory-set to .

#### To change the setting:

The LCD shows .

- Press the + or – key to select the desired calibration.  
(How to set the calibration is described in Chapter 3.4.)

### 3.3.1 Changing the Settings (Cont.)

For example:

CAL: 2

- Simultaneously press and then release the GAIN and ZERO keys.

The display shows

EXIT

and the settings are saved.

The instrument then changes back to measuring mode.

The display shows

0.0 cN



**The settings you made remain stored in the SC-PM memory even after the instrument is switched off.**

#### OR

- Press the ZERO key to change the setting for the:

#### Alarm function

The instrument is factory-set to

Alarm OFF

#### To change the setting:

The LCD shows

Alarm OFF

- Press the + or – key to enable or disable the alarm function.

For example:

Alarm ON

- Simultaneously press and then release the GAIN and ZERO keys.

The display shows

EXIT

and the settings are saved.

The instrument then changes back to measuring mode.

The display shows

0.0 cN

#### OR

- Press the ZERO key to set the:

#### High alarm limit

The high alarm limit is factory-set to 90% of the tension range of the supplied sensor,

for example:

Max 180.0

When you change the tension range, the high alarm limit is automatically set to 90% of the newly selected tension range.

#### To change the setting:

The LCD shows

Max 180.0

- Press the + or – key to set the desired high alarm limit.

For example:

Max 162.0

- Simultaneously press and then release the GAIN and ZERO keys.

The display shows

EXIT

and the settings are saved.

The instrument then changes back to measuring mode.

The display shows

0.0 cN

### 3.3.1 Changing the Settings (Cont.)

**OR**

- Press the ZERO key to set the:

#### **Low alarm limit**

The low alarm limit is factory-set to 10% of the tension range of the supplied sensor,

for example .

When you change the tension range, the low alarm limit is automatically set to 10% of the newly selected tension range.

#### **To change the setting:**

 **The settings you made remain stored in the SC-PM memory even after the instrument is switched off.**

The LCD shows .

- Press the + or – key to set the desired low alarm limit.

For example:

- Simultaneously press and then release the GAIN and ZERO keys.

The display shows  and the settings are saved.  
The instrument then changes back to measuring mode.

The display shows .

**OR**

- Press the ZERO key to change the setting for the:

#### **Tension range**

The tension range is factory-set for the supplied sensor.

You can also set the tension range for any other sensor that complies with the specifications in Chapter 4.0.1.

#### **To change the setting:**

The LCD shows .

- Press the + or – key to select the desired tension range.

For example:

- Simultaneously press and then release the GAIN and ZERO keys.

The display shows  and the settings are saved.  
The instrument then changes back to measuring mode.

The display shows .

**OR**

- Press the ZERO key to change the setting for the:

#### **Unit of measure**

The unit of measure is factory-set to .

You can also select daN, g, kg or lb for the unit of measure.

### 3.3.1 Changing the Settings (Cont.)

#### To change the setting:

The LCD shows Unit cN .

 The settings you made remain stored in the SC-PM memory even after the instrument is switched off.

- Press the + or – key to select the desired unit of measure.

For example: Unit kgs

- Simultaneously press and then release the GAIN and ZERO keys.

The display shows EXIT and the settings are saved.  
The instrument then changes back to measuring mode.

The display shows 0.0 cN .

#### OR

- Press the ZERO key to change the setting for the:

#### **Analog ZERO signal**

The analog interface is provided for customer signal processing or for connecting a line recorder which conforms to the current industrial standard. Please refer to Chapter 2.1 for the specifications.

The LCD shows Anl.ZERO .

You can now set the analog ZERO signal as described in Chapter 4.1.1.

- Simultaneously press and then release the GAIN and ZERO keys.

The display shows EXIT and the settings are saved.  
The instrument then changes back to measuring mode.

The display shows 0.0 cN .

#### OR

- Press the ZERO key to change the setting for the:

#### **Analog GAIN signal**

The analog interface is provided for customer signal processing or for connecting a line recorder which conforms to the current industrial standard. Please refer to Chapter 2.1 for the specifications.

The LCD shows Anl. GAIN .

You can now set the analog GAIN signal as described in Chapter 4.1.1.

- Simultaneously press and then release the GAIN and ZERO keys.

The display shows EXIT and the settings are saved.  
The instrument then changes back to measuring mode.

The display shows 0.0 cN .

#### OR

- Press the ZERO key to change the setting for the:

### 3.3.1 Changing the Settings (Cont.)

#### Channel selection

The LCD shows CHAN: 00 .



**The CHAN (channel selection) setting must always be 00.  
Do not change this setting.**

- Simultaneously press and then release the GAIN and ZERO keys.

The display shows EXIT and the settings are saved.  
The instrument then changes back to measuring mode.

The display shows 0.0 cN .

### 3.4 Sensor Calibration

All tension meters are calibrated with standard materials - such as polyamide monofilament (PA) - according to the SCHMIDT factory procedure; the material path is vertical. Any difference in process material size and rigidity from the standard material may cause a deviation of the accuracy. In 95% of all industrial applications, the SCHMIDT calibration has been proven to provide the best results and is used for comparative purposes. If required you can also operate the sensor with a material path other than vertical. Should the process material differ significantly from the SCHMIDT calibration material in size, rigidity or shape, we recommend special calibration using customer supplied material. If a different material path (e.g. horizontal) or special calibration using customer supplied material is required, you need to carry out static **ZERO** and **GAIN adjustment** as described in Chapter 3.4.1.

**1** Since **ZERO** and **GAIN** adjustments are always performed statically, the readings may differ under dynamic load.



### 3.4.1 ZERO and GAIN Adjustment

You can save up to three different calibrations.



The instrument is factory-set to

CAL: 1

. This is the factory calibration, which should not be overwritten.

#### Requirements:

- Two weights, one corresponding to 10% and one to 90% of the selected tension range, must be provided. Pay attention to the selected unit of measure (cN or kg).
- Sensor installed at measuring location.
- Instrument switched on as described in Chapter 3.1.1.
- Allow approx. 10 minutes for thermal stabilization of the instrument.

#### Selection of the material curve (calibration setting)

- Simultaneously press and then release the GAIN and ZERO keys.

The LCD shows **MENU** and then **DAMP: 04**.  
Press the ZERO key.

The LCD shows **CAL: 1** the currently active calibration setting.

- Press the + or – key to select the desired calibration.

For example: **CAL: 2**

- Simultaneously press and then release the GAIN and ZERO keys.

The display shows **EXIT** and the settings are saved.  
The instrument then changes back to measuring mode.

#### ZERO adjustment:

- Thread the process material through the measuring and guide rollers, following the red material path symbol on the front of the sensor.
- Hang a weight that corresponds to e.g. 10% of the tension range (pay attention to the correct unit of measure) from the process material, vertically, as shown in fig. 3.4.1. (Always use a fresh portion of the material to be measured.)
- Press and hold the ZERO key.

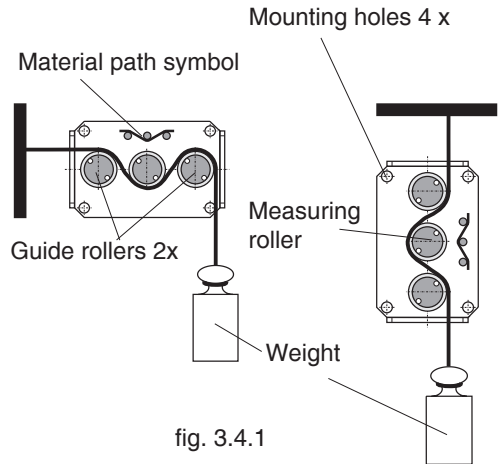

### 3.4.1 ZERO and GAIN Adjustment Cont.)

- Press the + or – key repeatedly until the tension value on the LCD is equal to the value of the suspended weight.

For example: Sensor model TS1-200

Weight 20 cN =

LCD display

- Release the ZERO key.  
The set value is saved to the calibration

curve e.g.  after approx. 10 sec. and the instrument changes back to measuring mode.



**The ZERO adjustment values are only saved permanently in the SC-PM memory after approx. 10 seconds. Therefore the unit must not be separated directly from the power supply.**

### GAIN adjustment:

#### Requirement:

ZERO adjustment carried out.

#### To carry out GAIN adjustment:

- Thread the process material through the measuring and guide rollers, following the red material path symbol on the front of the sensor.
- Hang a weight that corresponds to e.g. 90% of the tension range (pay attention to the correct unit of measure) from the process material, vertically, as shown in fig. 3.4.1. (Always use a fresh portion of the material to be measured.)
- Press and hold the GAIN key.
- Press the + or – key repeatedly until the tension value on the LCD is equal to the value of the suspended weight.

For example: Sensor model TS1-200

Weight 180 cN = Display

- Release the GAIN key.

The set value is saved to the calibration curve e. g.  after approx. 10 sec. and the instrument changes back to measuring mode.



**The GAIN adjustment values are only saved permanently in the SC-PM memory after approx. 10 seconds. Therefore the unit must not be separated directly from the power supply.**

- Check the adjustments with a fresh portion of the process material and repeat the procedure if necessary.

## 4 Interfaces

### 4.1 ANALOG Interface

The analog interface is provided for customer signal processing or for connecting a line recorder which conforms to the current industrial standard.

Please refer to Chapter 2.1 for the specifications.



**CAUTION The analog interface must be calibrated only by qualified electrical personnel.**



#### 4.1.1 ZERO and GAIN Adjustment of the ANALOG Interface

- Connect a volt meter to the ANALOG interface.
- Switch on the instrument as described in Chapter 3.1.1.
- Allow approx. 10 minutes for thermal stabilization of the instrument.

##### **ZERO adjustment:**

- Thread the process material through the measuring and guide rollers.
- Select the Analog ZERO setting:
- Simultaneously press and then release the GAIN and ZERO keys.  
The LCD shows menue.
- Press zero key so often till **Anl.ZERO** is shown in the display.  
Now the analog output can be zeroed.
- Press the + or – key repeatedly until the display of the volt meter connected to the ANALOG interface reads 0.0 volt.

The LCD shows **Anl.ZER+** or **Anl.ZER-**.

Check the setting and repeat the procedure if necessary.

- Press GAIN and ZERO simultaneously to exit the menu.

The display shows **EXIT** and the settings are saved.  
The instrument then changes back to measuring mode.

**or**

press ZERO to adjust GAIN

##### **GAIN adjustment:**

###### **Requirement:**

- ZERO adjustment carried out.

###### **To carry out GAIN adjustment:**

- Press the + or – key repeatedly until the display of the volt meter connected to the ANALOG interface reads 10.0 volts.

The LCD shows **Anl.GAI+** or **Anl.GAI-**.

Check the setting and repeat the procedure if necessary.

- Simultaneously press and then release the GAIN and ZERO keys.

The display shows **EXIT** and the settings are saved.  
The instrument then changes back to measuring mode.

## 4.2 DIGITAL Interface

### 4.2.1 The TENSION INSPECT 3 Program

The Tension Inspect software 3 from SCHMIDT is described in a separate user manual.

### 4.2.2 WINDOWS Terminal Program

The measured values can be transmitted over the RS-232 interface to a personal computer.

You can connect the computer to the INTERFACE of the SC-PM by using the EK0660 special cable which is available as an accessory.

The pin assignment of the INTERFACE is described in Chapter 2.2.

#### Command for communication with a PC (polling)

ASCII Code	Function	Description
d	Send	Transmit current reading to PC once.

#### Requirement:

A communication program, such as Terminal or HyperTerminal (provided on MS Windows Version 3.0 or later), must be installed and configured on the computer.

## 5 Online Sensor Specifications

### 5.1 TS, FS and MZ Series

TS series (Models TS1, TSP, TSH, TSL, TSF, TSB1, TSB2)

FS series (Models FS1, FSP, FSH, FSL, FSB1)

MZ series (Models MAZD, MBZD, MAZF, MBZF)

Calibration: According to SCHMIDT factory procedure

Accuracy: For 10% to 100% of range:

TS:  $\pm 1\%$  Full Scale

FS:  $\pm 1.5\%$  Full Scale

MZ:  $\pm 2\%$  Full Scale Remainder of Range and

Other Calibration Material:  $\pm 3\%$  full scale or better

Overload Protection: 100% of range

Measuring Principle: Strain gauge bridge

Measuring Roller Deflection: 0.5 mm max.

Signal Processing: Analog

Output Signal: 0 - 1 V DC (standard)

Damping ( $f_d$ ): Standard: 30 Hz (other values on request)

Temperature Coefficient: Gain: less than  $\pm 0.05\%$  full scale / °C

Temperature Range: 10 - 45 °C

Air Humidity: 85% RH, max.

Power Supply: TS standard: + 12 bis + 24 V DC (21 mA, regulated)

FS, MZ standard: + 15 bis + 24 V DC (21 mA, regulated)

Further technical details are provided in the Operating Instructions for the sensors.

### 5.2 SF Series

Models SFZ and SFK

Accuracy: 0.5 % full scale

Max. applied Force: 160 % full scale, overload protection afterwards

Overload Protection: 10 times of nominal load, max. 3200 N

Lateral force at the axis: max. 100 % Nennlast

Measuring Principle: Dehnungsmessstreifen-Vollbrücke

Output Signal: 5 - 20 N: 1 mV/V

ab 50 N: 1.5 mV/V

Temperature Range: 10 - 70 °C

Power Supply: 10 V DC

Further technical details are provided in the Operating Instructions for the sensors.

## 6 Service and Maintenance

The display unit is maintenance-free.

## 7 Cleaning

For cleaning the unit, do not use any



### **AGGRESSIVE SOLVENTS**

such as trichloroethylene or similar chemicals.



### **NO WARRANTY OR LIABILITY**

shall be accepted for damage resulting from improper cleaning.

## 8 Correspondence

Should you have any questions regarding the instrument or Operating Instructions, or their use, please indicate above all the following details which are given on the ID plate:

- 1.) Model
- 2.) Serial number

## 9 Repairs

### **Shipping instructions:**

We kindly ask for return free of charge for us, if possible by airmail parcel. All occurring charges, if any (such as freight, customs clearance, duty etc.), will be billed to customer. For return from foreign countries, we ask you to include a proforma invoice with a low value for customs clearance only, e.g. 50 Euro, each and to advise the shipment in advance by fax or eMail.



**To avoid unnecessary follow-up questions, and the resulting loss of time or possible misunderstandings, please return the unit with a detailed fault description to our service department. Please indicate in your order whether you require an Inspection Certificate 3.1 according to DIN EN 10204.**

**Service address:**

**HANS SCHMIDT & Co GmbH  
Schichtstr. 16  
D-84478 Waldkraiburg  
Germany**

Notizen:

---

---

---

---

---

**SCHMIDT**

control instruments

**SCHMIDT-Test-Instruments**  
*indispensable in production monitoring,  
quality control and automation*  
**We solve your measuring problems:**



*Tension Meter*



*Force Gauge*



*Torque Meter*



*Tachometer*



*Speed- and Lengthmeter*



*Electronic Lengthmeter*



*Stroboscope*



*Screen Printing Tension Meter*



*Thickness Gauge*



*Yarn Package Durometer and Shore Durometer*



*Sample Cutter*



*Balance*



*Moisture Meter*



*Leak Tester*



*Softometer*

**More than 70 years - Worldwide -**

**Hans Schmidt & Co GmbH**

**Mailing address:**

P. O. B. 1154  
84464 Waldkraiburg Germany

**Shipping address:**

Schichtstr. 16  
84478 Waldkraiburg Germany

**Phone:**

int. + 49 / (0)8638 / 9410-0

**Fax:**

int. + 49 / (0)8638 / 4825

int. + 49 / (0)8638 / 67898

**e-mail:**

[info@hans-schmidt.com](mailto:info@hans-schmidt.com)

**Internet:**

<http://www.hans-schmidt.com>