



Instruction Manual

Valid as of: 01.02.2010 • Please keep the manual for future reference!



Contents

1	Warranty and Liability	3
1.1	Notices within the Operating Instructions	3
1.2	Responsibilities of the Operating Company	3
1.3	Responsibilities of the Personnel	3
1.4	Informal Safety Measures.....	4
1.5	Training of the Personnel	4
1.6	Intended Use	4
1.7	Dangers in Handling the Device	4
1.8	Copyright	4
1.9	Declaration of Conformity	4
2	Available Models	5
2.1	Specifications	5
2.2	Delivery Includes	6
2.3	Unpacking.....	6
3	Operating Procedure	6
3.1	Notices Before Starting Measurement.....	6
3.2	Measuring with the Durometer	6
3.3	Verification of Calibration.....	7
3.3.1	Verify calibration of durometer models: HP-2.5, HP-5 and HP-10.....	7
3.3.2	Verify calibration of durometer models: HP-2.5-F, HP-5-F and HP-10-F8	
4	Optional Accessories	9
5	Service and Maintenance	11
6	Cleaning	11
7	Verification Intervals	11
8	Correspondence	11
9	Repairs	11

1 Warranty and Liability

In principle, the supply of the device is subject to our "General Conditions of Sale and Delivery." These have been provided to the operating company on conclusion of the contract, at the latest.

Warranty:

- SCHMIDT Durometers are warranted for 12 months.

Parts subject to wear, electronic components and measuring springs are not covered by the warranty. No warranty or liability will be accepted for bodily injury or property damage resulting from one or several of the following causes:

- Misuse or abuse of the device.
- Improper mounting, commissioning, operation and maintenance of the device (e.g. verification interval).
- Operation of the device if any safeguards are defective or if any safety and protection precautions are not properly installed or not operative.
- Failure to comply with the notices in the Operating Instructions regarding transport, storage, mounting, commissioning, operation, maintenance and setup of the device.
- Any unauthorized structural alteration of the device.
- Insufficient inspection of device components that are subject to wear.
- Opening the device or improper repair work.
- Disasters caused by the effects of foreign objects or by force majeure.

1.1 Notices within the Operating Instructions

The fundamental prerequisite for the safe handling of this device and its troublefree operation is the knowledge of the basic safety notices and safety instructions.

These Operating Instructions contain the most important notices for the safe operation of the device.

These Operating Instructions, in particular the safety notices, must be observed by any person who works with the device. In addition, the local valid rules and regulations for the prevention of accidents must be complied with.

The representations within the Operating Instructions are not true to scale.

The dimensions given are not binding.

General indications of direction, such as FRONT, REAR, RIGHT, LEFT apply when viewing the front of the device.

1.2 Responsibilities of the Operating Company

In compliance with the EC Directive 89/655/EEC, the operating company agrees to only permit persons to work with the device who:

- are familiar with the basic regulations on industrial safety and accident prevention and who have been trained in handling the device.
- have read and understood the chapter on safety and the warning notices in these Operating Instructions and have confirmed this with their signatures.
- are examined regularly on their safe and conscientious working method.

1.3 Responsibilities of the Personnel

All persons who work with the device agree to perform the following duties before starting work:

- to observe the basic regulations on industrial safety and accident prevention.
- to read the chapter on safety and the warning notices in these Operating Instructions and to confirm with their signatures that they have understood them.

1.4 Informal Safety Measures

The Operating Instructions must always be kept on hand where the device is operated. Apart from the Operating Instructions, the generally and locally valid regulations on accident prevention and environmental protection must be provided and complied with.

1.5 Training of the Personnel

Only trained and instructed personnel is permitted to work with the device. The responsibilities of the personnel must be clearly defined for mounting, commissioning, operation, setup, maintenance and repair. Trainees may only work with the device under the supervision of an experienced personnel

1.6 Intended Use

The device is intended exclusively to be used as a Durometer. Any other use or any use exceeding this intention will be regarded as misuse. Under no circumstances shall HANS SCHMIDT & Co GmbH be held liable for damage resulting from misuse.

The intended use also includes:

- Complying with all notices included in the Operating Instructions and observing all inspection and maintenance works.

1.7 Dangers in Handling the Device

The device was designed according to the state of the art and the approved safety standards. Nevertheless, its use may cause serious or fatal injury to the user or third persons, and/or an impairment of the device or of other material assets.

The device may only be applied:

- For its intended use in a faultless condition with regard to the safety requirements.
- Malfunctions that could impair safety must be remedied immediately.
- Personal protective equipment must be used according to the EC Directive 89/686/EEC.



The device must not be operated in potentially explosive areas and must not come into contact with aggressive substances.

1.8 Copyright

The copyright on these Operating Instructions remains with the company HANS SCHMIDT & Co GmbH.

These Operating Instructions are intended for the operating company and its personnel only. They contain instructions and notices that may only be reproduced on the prior written permission of

HANS SCHMIDT & Co GmbH

and under indication of the complete reference data. Violations will be prosecuted.

1.9 Declaration of Conformity

Our mechanical durometers do not belong to the EC machinery directive 2006/42/EC and do not have a CE mark.

2 Available Models

General information on textile durometers

The principle used to measure the “firmness” or “hardness” of textile material is based on measuring the resistance force of the penetration of a ball sensor into a bobbin under a constant spring load. This principle is based on the Shore hardness test procedure.

The display range of the textile durometers covers a range from 0 to 100 units, where 0 corresponds to the minimum and 100 to the maximum hardness value.

These units have no formal industry standards or engineering classification, and are not related to a specific Shore value or other known value. Since there are no international standards that can be used to compare against, we have developed a special test procedure for verifying calibration (see Chapter 3.2).

Model	Indenter  mm Ø	Typical Applications
HP-2.5	Ball 2.5	Closely wound bobbins of synthetic fibers, etc.
HP-5	Ball 5	Loosely wound bobbins of synthetic fibers and closely wound natural fibers
HP-10	Ball 10	Very loosely wound bobbins of thick yarns, such as carpet yarns
HP-2.5-F	Flat 2.5	Same as Model HP-2.5 with a flat working face for measuring warp beams, or for bobbin diameters with over 400 mm
HP-5-F	Flat 5	Same as Model HP-5 with a flat working face for measuring warp beams, or for bobbin diameters with over 400 mm
HP-10-F	Flat 10	Same as Model HP-10 with a flat working face for measuring warp beams, or for bobbin diameters with over 400 mm

2.1 Specifications

Model	HP-2.5, HP-5, HP-10	HP-2.5-F, HP-5-F, HP-10-F
Display Range:	0 - 100 hardness units	0 - 100 hardness units
Depth of Indentation:	0 - 2.5 mm	0 - 2.5 mm
Test Pressure*:	approx. 12.5 N	approx. 12.5 N
Meas. Spring Force:	0.55 - 8.065 N	0.55 - 8.065 N
Working Face Radius:	55 mm	
Working Face Dia.:		45 mm Ø
Scale Diameter:	51 mm	51 mm
Weight net (gross):	approx. 300 g (appx. 500 g)	approx. 300 g (approx. 500 g)
Dimensions (LxWxH):	50 x 60 x 110 mm	50 x 60 x 110 mm

* Corresponds to Shore A test procedure

** Pressure on test material surface when outer shell is in measuring position (colored line)

2.2 Delivery Includes

- Durometer
- Operating manual
- Specific Test Report 2.1 as per EN 10204
- Carrying case

2.3 Unpacking

Unpack the instrument and inspect it for any shipping damage.
Notices of defect must be announced immediately, at the latest within 7 days on receipt of the goods.

3 Operating Procedure

3.1 Notices Before Starting Measurement



**Have you read and understood the Operating Instructions, in particular Chapter 1 „Basic Safety Notices“ ?
You are not permitted to operate the instrument before doing so.**

Before working with the instrument you must put on your personal protective clothing, if necessary. For example, eye protectors, gloves, etc.

3.2 Measuring with the Durometer

General information:

- Each test sample has to be tested in at least three different points.
- The hardness reading must be recorded 3 seconds after pressing down the knurled outer shell.
- The durometer has two movable markers that can be rotated around the faceplate to mark any desired measuring range within the display range.

Measurement procedure:

- Place the instrument on the material to be tested. The durometer must be level, and the sensing pin must be perpendicular to the bobbin axis. Any angle other than perpendicular may cause error.
- Holding the knurled, spring-loaded outer shell between fingers, press downwards until the lower edge of the shell meets the red line marked on the housing. This ensures that the same amount of pressure is applied from measurement to measurement and prevents measuring errors.
- Record the reading after approx. 3 seconds. The hardness scale covers a range from 0 to 100, where 0 corresponds to the minimum and 100 to the maximum hardness value.

Each test sample has to be tested in at least three different points.

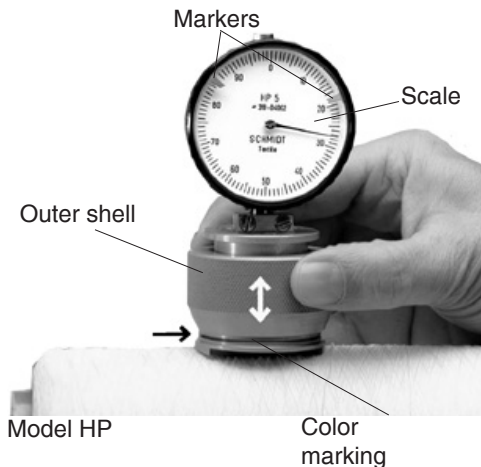

3.3 Verification of Calibration

You can test that the instrument is functional and undamaged by pressing the flat-bottomed models ("F" models) against a smooth, level surface (such as glass or marble). When fully pressed down, the scale pointer should make one full turn on the scale, from zero to zero. The scale pointer should return to the initial zero position when you release pressure. If it does not, return the instrument to the manufacturer for servicing. On models with a concave base (for measuring bobbins, etc.) you can perform a similar "full scale" test using the optional Zero Test Block (part number HP-PT). Optional calibration certification must be ordered separately, prior to delivery of the instrument. Subsequent calibration is only possible at the manufacturer's facilities.

3.3.1 Verify calibration of durometer models: HP-2.5, HP-5 and HP-10 (with concave-shaped base)

- Press the durometer down on the optional Zero Test Block (HP-PT) (fig. 3.3.1). Do not move the spring-loaded outer shell.

The scale pointer should make one full turn on the scale, from zero to zero. If the result of verification is positive, the durometer should show correct readings.

Models: HP-2.5, HP-5 and HP-10

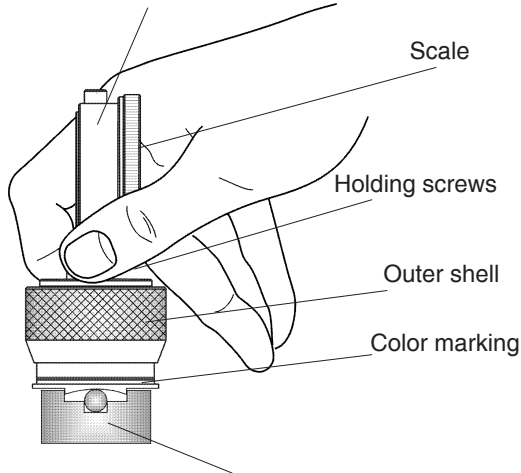

fig. 3.3.1 Zero Test Block Model HP-PT for textile durometer models with concave-shaped base



Do not loosen the holding screws of the movement under any circumstances. Loosening these screws may alter the calibration of the instrument.

3.3.2 Verify calibration of durometer models: HP-2.5-F, HP-5-F and HP-10-F
(with flat base)

- Press the durometer down on a glass plate (fig. 3.3.2).

Do not move the spring-loaded outer shell.

The scale pointer should make one full turn on the scale, from zero to zero.

If the result of verification is positive, the durometer should show correct readings.

Models: HP-2.5-F, HP-5-F and HP-10-F

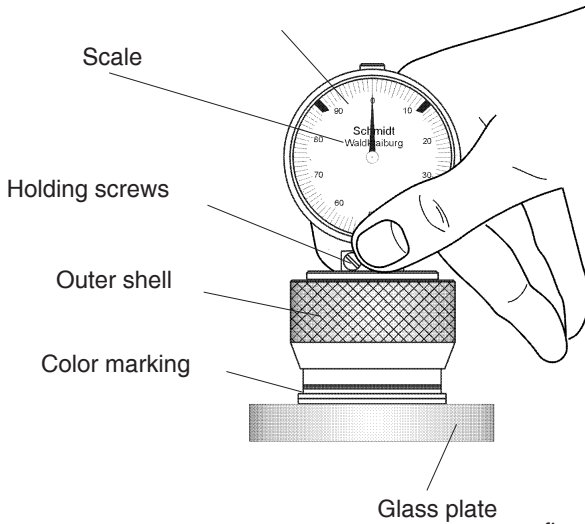

fig. 3.3.2



Do not loosen the holding screws of the movement under any circumstances. Loosening these screws may alter the calibration of the instrument.

4 Optional Accessories

Memory Pointer (Option Code M)

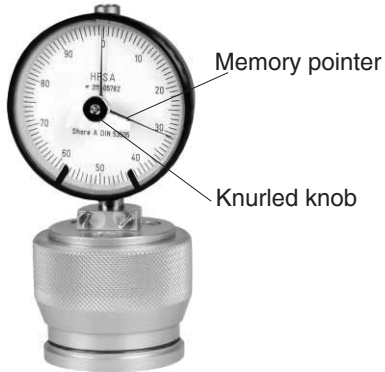

The durometer is available with a memory pointer which can be ordered under option code M. The memory pointer moves with the scale pointer when a measurement is taken. However, when pressure on the outer shell is released, and the scale pointer returns to zero, the memory pointer remains in position, marking the highest reading (PEAK) of the measurement.

Before beginning a new measurement:

- Rotate the knurled knob to reset the memory pointer to the zero position.

Test Stand



Model PSHP for serial testing

- Spring-loaded lever for easy use
- Height adjustable from 0 to 200 mm
- Travel of operating lever: 40 mm
- Dimensions LxWxH: 162 x 100 x 320 mm
- Net weight: approx. 2.3 kg

Base plate and prisms optionally available, please ask for further details.

Test Block (For textile hardness tester with curved working face)



Model HP-PT

for checking displacement

5 Service and Maintenance

The tension meter is easy to maintain. Depending on operating time and load, the tension meter should be checked according to the locally valid regulations and conditions (as described in Chapter 3.3). The use of other test methods than the procedure described in Chapter 3.3 may cause deviating measuring results.

6 Cleaning

For cleaning the unit, do not use any



AGGRESSIVE SOLVENTS

such as trichloroethylene or similar chemicals.



NO WARRANTY OR LIABILITY

shall be accepted for damage resulting from improper cleaning.

7 Verification Intervals

The question of finding the right frequency of calibration accuracy verification depends on several different factors:

- Operating time and load of the SCHMIDT hardness tester
- Tolerance band defined by the customer
- Changes of the tolerance band compared to previous verifications of calibration

Therefore, the interval between verifications must be determined by the user's Quality Assurance Department based on the user's experience.

Assuming normal operating time and load as well as careful handling of the hardness tester, we recommend a verification interval of 1 year.

8 Correspondence

Should you have any questions regarding the tension meter or Operating Instructions, or their use, please indicate above all the following details which are given on the ID plate:

- 1) The tension meter model
- 2) The serial number

9 Repairs

Shipping instructions:

We kindly ask for return free of charge for us, if possible by airmail parcel. All occurring charges, if any (such as freight, customs clearance, duty, etc.) will be billed to customer.

For return from foreign countries, we ask you to include a proforma invoice with a low value for customs clearance only, e.g. 50 Euro, each and to advise the shipment in advance by fax or eMail.



To avoid unnecessary follow-up questions, and the resulting loss of time or possible misunderstandings, please return the tension meter with a detailed fault description to our service department. Please indicate in your order whether you require an calibration certificate with calibration report.

**Service address: HANS SCHMIDT & Co GmbH
Schichtstr. 16
D-84478 Waldkraiburg
Germany**

Notes:

SCHMIDT

control instruments

SCHMIDT-Test-Instruments
*indispensable in production monitoring,
quality control and automation*
We solve your measuring problems:



Tension Meter



Force Gauge



Torque Meter



Tachometer



Speed- and Lengthmeter



Electronic Lengthmeter



Stroboscope



Screen Printing Tension Meter



Thickness Gauge



Yarn Package Durometer and Shore-A Durometer



Sample Cutter



Balance



Moisture Meter



Leak Tester



Softometer

More than 70 years - Worldwide -

Hans Schmidt & Co GmbH

Mailing address:

P. O. B. 1154
D -84464 Waldkraiburg Germany

Shipping address:

Schichtstr. 16
D -84478 Waldkraiburg Germany

Phone:

int. + 49 / (0)8638 / 9410-0

Fax:

int. + 49 / (0)8638 / 4825

int. + 49 / (0)8638 / 67898

e-mail:

info@hans-schmidt.com

Internet:

<http://www.hans-schmidt.com>