

# 1 Summary

SG Series Large Scale Analog force gauge is a sample instrument for push and pull test. It have large capacity, high accuracy , easy operation.

# 2 Characteristics

1. It is designed with double needles and have peak hold function and track the test value.
2. It has tolerance indication for judging the requirement test result.
3. N and kgf tow unit show on the scale.  
(the unit can be choosed for detail requirement.)
4. It suit for working in electromagnetic interference environment.
5. Patent number of out-design:  
ZL200930096196.9  
ZL200920078157.0

# 3 Parameter

Model	SG-10KC	SG-20KC	SG-50KC	SG-100KC	SG-200KC	
Capacity	10KN	20KN	50KN	100KN	200KN	
Resolution	0.05KN	0.1KN	0.2KN	0.5KN	1.0KN	
Accuracy	±2%FS					
Load direction	Compression					
Weight	1.25Kg	1.35Kg	4.6Kg	7.7Kg	11.4Kg	

# 4 Structure

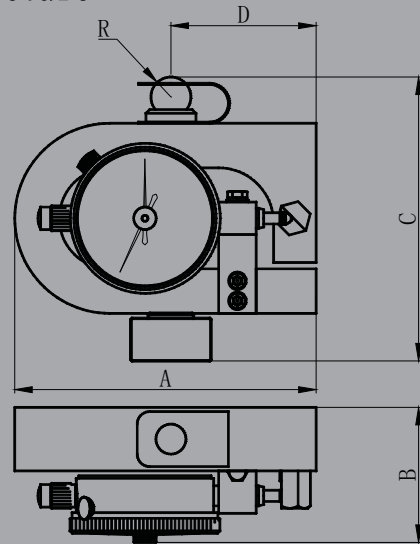

SG-10KC、SG-20KC、SG-50KC Dimension

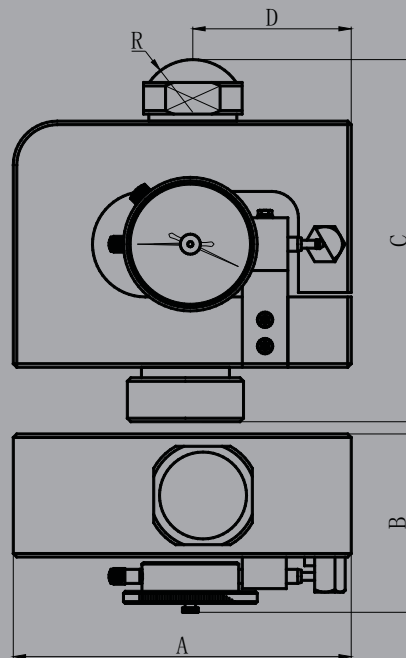

SG-100KC、SG-200KC Dimension

Model	10KC	20KC	50KC	100KC	200KC
A	120.6	120.6	150	166.5	192
B	54	54	78.5	88	98.5
C	113.5	113.5	141	167	206
D	58.1	58.1	70	84	90
R	SR16	SR16	SR18	SR22	SR30

Unit: mm

## 5 Cautions

1. The user should make a corresponding safty regulations for better using the SG series large scale force gauge.
2. Please choose the correct model depend on the test load .
3. Do not test overload,or it will cause danger.
4. SG series large scale force gauge only used for measuring force.Please do not use for Others area.
5. Please contact the distributor or manufacture in time if the gauge be damaged or out of tolerance.
6. Never disassemble, repair or remode the stand by yourself, as it will cause perpetual destroy.
7. It calibration refer to JJG455-2000 document. Cycle do not over 1 year.
8. Please pay attention to the testing direction, It should in accordance to with pressure head as follows picture:

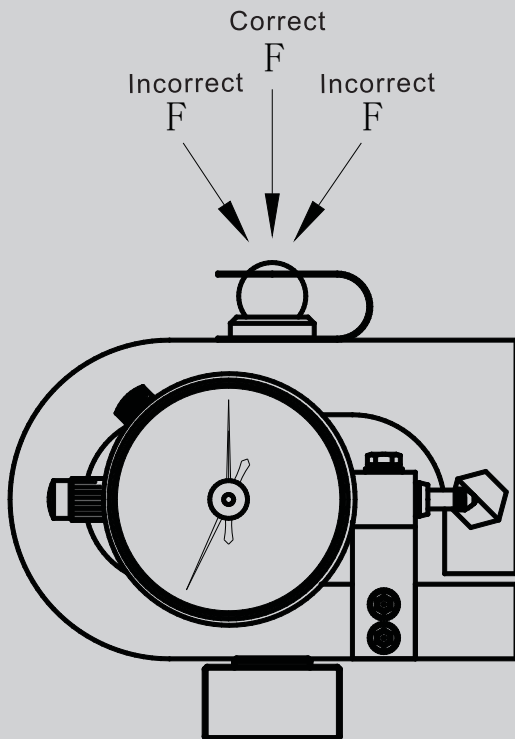

## 6 Packing list

NO.	Name	Quantity
1	Main body	1
2	Pressure head	1
3	Base plate	1
4	Certification	1
5	User's manual	1

**MANUFACTURER: WENZHOU  
SUNDOO INSTRUMENTS CO.,LTD**

add: Building E,NO.10 High-tech industrial  
Zone,wenzhou,China

Zip: 325013

TEL: +86 577 88609905

FAX: +86 577 88390155

Http://www.sundoo.com

E-mail:export@sundoo.com