

1 Function

SPF Keystroke Test Stand, is designed specially for testing keystroke. It is adapted with SH-F Series Force Gauge, used for testing compression force of keyboard, button or knob with high accuracy and easy operation.

- Dimension: L150×W210×H260 mm;
- Capacity: 500N;
- Stroke: 25mm;
- Adapt with (purchase additionally) : SH-2F, SH-10F, SH-20F、SH-100F.

2 Structure



SPF Keystroke Test Stand

Note: SH-F Keystroke Force Gauge should be purchased separately.

3 Installation

1. The test stand can be used horizontally on various working tables. If also can be fixed on the working table by screw on the base as use' s requirement.

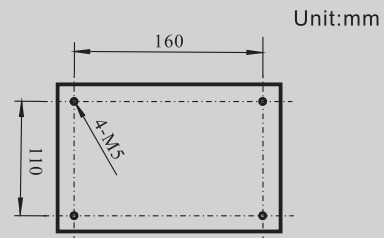

Vertical Installation of 4-M5 Screw on Base

2. Installation Dimension:

Install force gauge on test stand through backboard, and dimension of backboard is as follows:

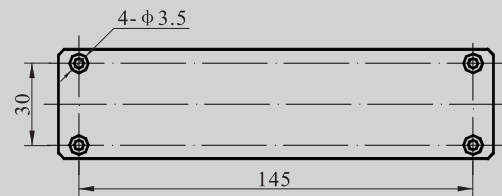

3. Installation of SH-F Force Gauge: tighten 4 pieces of M3x8 screws (in tool box) into hole on backcover of force gauge through deep hole on backboard.

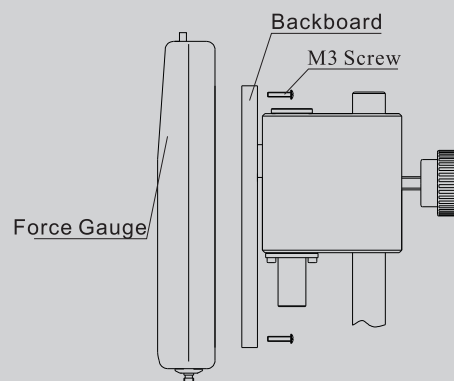

4 Maintenance

1. The rated load of this test stand is 500N, please do not use it with exceeding load, which may destroy the machine, or cause danger.
2. Handle lightly during use or moving.
3. Please keep away from water, oil and other liquid.
4. Please clean the machine by soft cloth.
Dip the cloth in the water with cleanser, then dry it and clean the dirt. Do not use the easy volatile chemical substance, such as volatile oil, thinner, alcohol.
5. Do not tear down, repair, or update the machine by yourself, which may cause permanent trouble.

5 Operation

Install SH-F Force Gauge on this SPF Test Stand, and put tested sample on proper place of test stand. Loosen lock handwheel to adjust height of slide carriage, then tighten it. Make push head of force gauge point to tested key or button, and turn handwheel to press it. Loosen handwheel when "Click and pop" sound appear, and force gauge will back to place. After one test, the number showed on screen of force gauge will be max force of pressing the button or key (Please refer to users' manual of SH-F Force Gauge for its detail operation).

6 Packing list

Number	Name	Quantity
1	SPF Main Body	1
2	Manual	1
3	Qualification Certificate	1

**MANUFACTURER: WENZHOU
SUNDOO INSTRUMENTS CO., LTD**
add: Building E, NO.10 High-tech industrial
Zone, wenzhou, China
Zip: 325013
TEL: +86 577 88609905
FAX: +86 577 88390155
Http://www.sundoo.com
E-mail: export@sundoo.com