

1 Summarize

STK Analog Torque Gauge is the ideal tool for testing the low torsion of torque. It is with exquisite design, light in weight and easy to use. The three direction of chuck chisel can block cylindrical object firmly; With two way scale of the calibrate scale, fasten two-way test from side to side, it is convenient to read the test data with two calibrate scales which test from opposite sides.

2 Structure

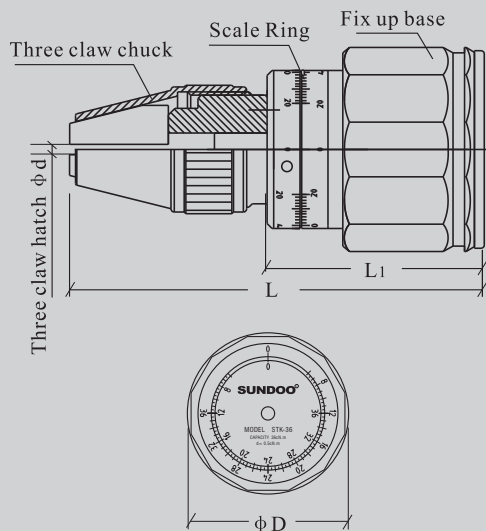

STK Analog Torque Gauge

3 Cautious

1. Do not make test beyond the max load of torsion, it will hurt the torque meter.
2. Avoid violent shock or fall off the meter, it will hurt the meter and make it distortion, which weak its precision and endurance.
3. Do not apply the meter near somewhere water, oil or other liquid splashed, it will shatter or destroy the torque meter.
4. Please check the torque meter periodically.
5. Applying or putting away the torque meter, please clean up the chips, oil, water and other contamination. Cleaning up can prolong its life-span.

4 Parameter

Model	Capacity cN.m	Resolution cN.m	Dimension mm				Accuracy
			L	L ₁	D	d	
STK-0.45	0.05~0.45	0.01	99	51	44	1~7	±3% FS
STK-0.9	0.1~0.9	0.02					
STK-1.5	0.2~1.5	0.02					
STK-3	0.3~3	0.05					
STK-6	0.6~6	0.1	130	66	64	1-9	
STK-12	1~12	0.2					
STK-24	2~24	0.5					
STK-36	4~36	0.5					
STK-60	6~60	1					
STK-90	10~90	1	2				
STK-150	20~150	2					

5 Operation

1. Checking the scale in “0” position before use, inaccuracy allow within half resolution.
2. Install the torque meter fixing device or hold it by hand.
3. on the test, unscrew the three claw chucks, insert the tested sample, screw the chucks, let it fix the tested sample firmly.
4. Turn around the tested sample or reverse the display base for getting the test value.

Note: The capacity above model SKT-36 have locked button, press it after you tighten the chucks, please do not give force for the meter or exceed the load.

6 Reading the tested value

1. Fix display base, turn the tested sample on clockwise, read tested value on the outer of A scale which corresponding with B scale “0” position. Or the green value on C scale. If turn on counter clockwise, read the inner value of A scale which corresponding with B scale “0” position or red value on C scale.
2. Fix tested sample, turn the display base on clockwise, read tested value on the inner of B scale which corresponding with A scale “0” position, or the red value on C scale. If turn on counter clockwise, read the value on the outer of B scale which corresponding with A scale “0” position, or green value on C scale.

Note: above STK-36 (Including SKT-36) have hold peak function, if need it, the hold peak needle should be turn to corresponding “0” position.

7 Packing List

Number	Name	Quantity
1	STK Torque Meter	1
2	Certification	1
3	Manual	1

**MANUFACTURER: WENZHOU
SUNDOO INSTRUMENTS CO., LTD**
add: Building E, NO.10 High-tech industrial
Zone, wenzhou, China
Zip: 325013
TEL: +86 577 88609905
FAX: +86 577 88390155
Http://www.sundoo.com
E-mail: export@sundoo.com