

CONTINUATION

Data of the manual is described equally upon the latest product, because of improvement or other change, description of manual may differ from practical situationslightly. Our company will reserve the right of correcting at any moment, it is difficult to notify the corrected place one by one.

The manual copyright belongs to Wenzhou sundoo Instruments Co.,Ltd.No permission, any company and individual mustn't copy content of the manual in any ways.

STW Series 全 自 动 扭 矩 试 验 机
User Manual **FULL-AUTOMATIC TORQUE TESTER**

制造商：温州山度仪器有限公司

MANUFACTURER: WENZHOU SUNDOO INSTRUMENTS CO.,LTD

地址：温州高新技术产业园区10区E幢

Add: Building E, No.10 High-tech Industrial Zone Wenzhou China

Zip: 325013

Tel: +86 577 88609905 Fax:+86 577 88390155

Http://www.sundoo.com E-mail:export@sundoo.com

Thank you very much for your purchase of STW full-automatic torque tester.

This torque tester adopts advanced electric technology and high-efficiency mechanical drive. Compared to traditional torque tester, higher accuracy, better stability, higher automation. Various test mode inside, simpler and more efficient for operation. The drive mechanism adopts servo system for accurate positioning. High accuracy sensor for test precision and stability. High resolution colorful touch screen for convenience and intuition. Before using the instrument, please read the manual carefully for accurate data and effective protection.

Contents

Parameter·····	2
Functions·····	3
Features·····	3
Work environment·····	3
Attention and maintenance·····	4
Part names and functions·····	4
Operation keypad·····	5
Introduction of product functions·····	6
Packing list·····	18

①Back:

“ZERO” of curve place means finished curve data, and back to interface of curve save by pressing the button.

If the curve place is one/two/three, back to interface of view by pressing the button.

②Escape: back to work interface of initialization by pressing the button.

III、 Operation sample

1、 Example: Test the angle when torque is 10N.m ? speed is 0.1r/min.

①Put pole on instrument.

②Enter interface of parameters setting by pressing “” button, test direction is clockwise, test mode is “ constant torque”, no-load speed is 1r/min (change the speed according to actual requirement), test speed is 0.1r/min, constant torque is 0010.00N.m, then escape.

③Start to test, and it will finish test automatically.

2、 Example: Test the torque when angle is 36 degrees ? test speed is 0.1r/min.

①Put pole on instrument.

②Enter interface of parameters setting by pressing “” button, test direction is clockwise, test mode is “ constant angle”, no-load speed is 1r/min (change the speed according to actual requirement), test speed is 0.1r/min, constant angle is 36 degrees, then escape.

③Start to test, and it will finish test automatically.

Packing list

Item	Name	Quauntity
1	Main body	1
2	Power adoptor	1
3	Manual	1
4	Factory inspection certificate	1
5	Qualification card	1

7、Interface of data view

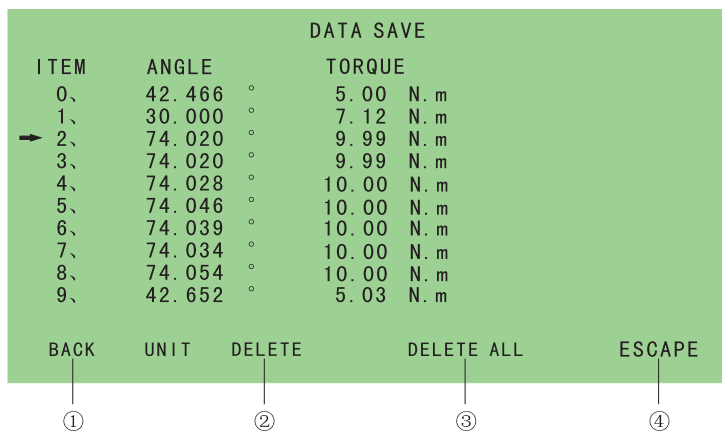

- ①Back: back to interface of view by pressing the button.
- ②Delete: delete data which “→” point by pressing the button.
- ③Delete all: delete all data by pressing the button.
- ④Escape: back to work interface of initialization by pressing the button.

8、Interface of test report

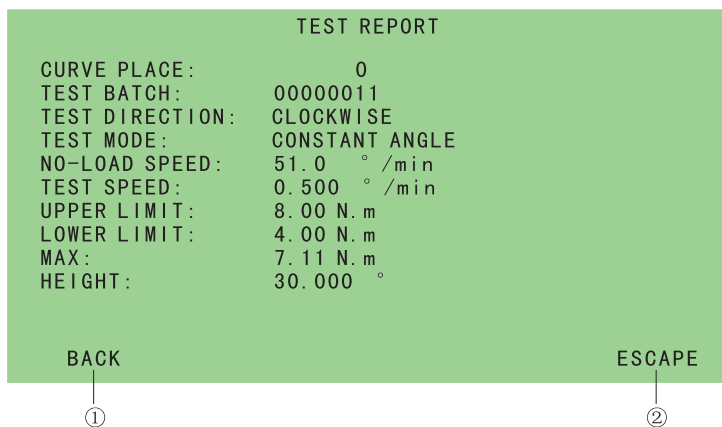

Parameter

Model	STW-500
Capacity	500N.m
Resolution	0.05N.m
Torque Test Range	2%~100%FS
Accuracy	±1%
Test Speed	0.1~500 mm/min
Speed Accuracy	±1%
Test Angle Range	-9999.99°~9999.99°
Angle Resolution	0.01°
Specimen Length	500mm
Power	AC 220V
Dimension	1530mm×750mm×400mm

Functions

STW full-automatic torque tester adopts advanced electric technology and high-efficiency mechanical drive. It has accurate loading rate and testing range. High accurate and sensitive for load、deformation、angle test and control.

Features

- 1、800*480 pixel TFT colorful screen with touch functions, peak/real-time value/torque curve display at the same time. It can monitor and retrospect the whole process of test.
- 2、Different test mode for different test requirements: manual mode, constant torque mode, constant angle mode.
- 3、Save 10 test value and 3 groups test curve.
- 4、Three units option: N.m、kgf.cm、lbf.in, automatic exchange.
- 5、Automatically back to start location after test finish.
- 6、Two speed mode, high speed approach and low speed collect.
- 7、Servo drive system, high efficiency transmission, low noise and good stabilization.
- 8、High accuracy sensor, promise test precision.
- 9、Automatic off mode without any operation, time is set freely.

Work environment

- 1、Work temperature: 20°C±10°C.
- 2、Relative humidity:35%RH~65%RH.
- 3、No shock and corrosive material around.



Caution Wrong operation may damage the equipment or even cause serious accident. There are important precautions and operation methods listed in the manual, so please read it carefully before using the equipment. If shock load is tested, please choose the torque tester whose capacity is double than the needed load.



- 1、Please wear protective mask and gloves to protect you from scattering pieces during fracture test.
- 2、Do not use damaged or warped clamps to avoid them off or breaking down to cause hurt.

6、Interface of view

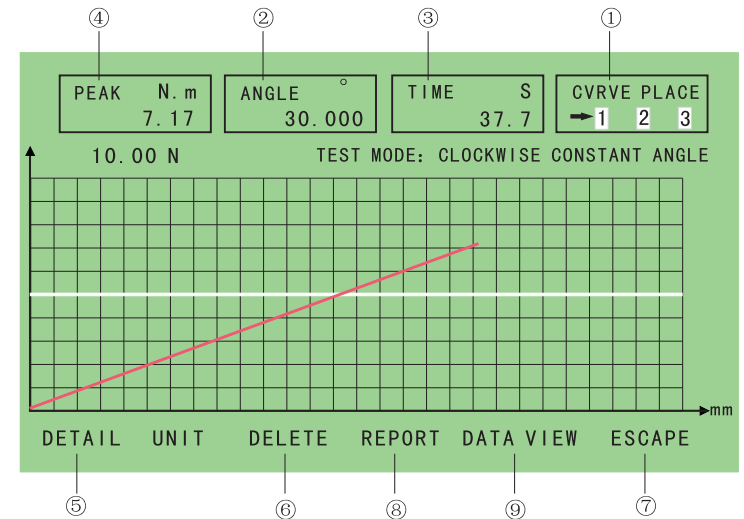

①Curve place:

White typeface means stored curve.

Other color means no curve.

“ → ” point to current curve place.

②Angle: total angle of current storage curve.

③Time: total time of current storage curve.

④Peak: max value of current storage curve.

⑤Detail: enter interface of curve details by pressing the button.

⑥Delete: delete the curve by pressing the button.

⑦Escape: back to work interface of initialization by pressing the button.

⑧Report: enter interface of test report by pressing the button.

⑨Data view: enter interface of data view by pressing the button.

5、Interface of curve details

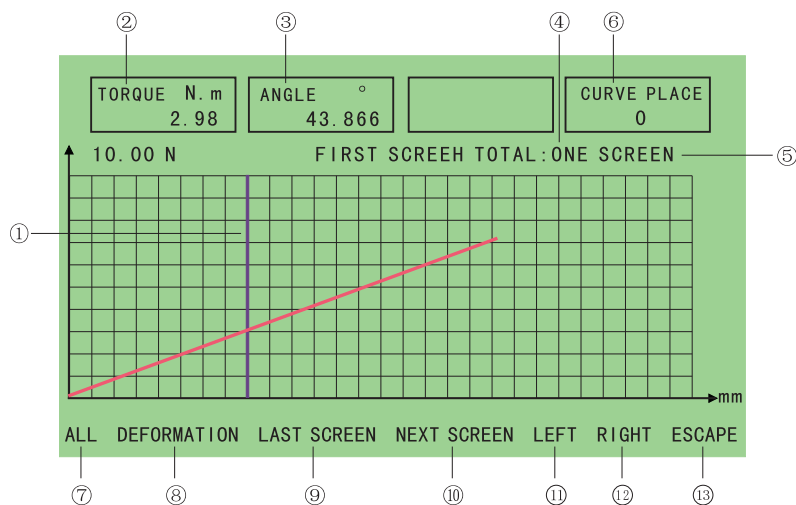

①Cursor: point to current curve view point, Pressing“◀”“▶”once move a grid, Pressing“◀◀”or“▶▶”all the time move the cursor quickly.

②Torque: current torque on curve.

③Angle: the angle after finishing test.

④Current screen position .

⑤Total data on curve.

⑥Curve place: current curve storage place.

⑦All buttons

If curve place is ZERO, press the button and back to interface of curve save.

If curve place is ONE、TWO、THREE, press the button and back to interface of view.

⑧Deformation: displacement data change to deformation data by pressing the button.

⑨Last screen: curve back to last screen by pressing the button.

⑩Next screen: curve back to next screen by pressing the button.

⑪Left: cursor move a grid by pressing the button.

⑫Right: cursor move a grid by pressing the button.

⑬Escape: back to work interface of initialization.

- 3、 This equipment is used for testing torque after distortion. Do not force on the direction of sensor and bending.
- 4、 Do not use the equipment with overload. The equipment has overload protection, and no protection for shock load.
- 5、 When the force value show red, it means that the sensor exceeds the capacity and you should stop operating.

Attention and maintenance

- 1、 Using the instrument with overload will damage, even cause danger.
- 2、 Do not hit the screen or put anything on it.
- 3、 Do not use nails and pointed tools to press the buttons.
- 4、 Do not operate the equipment near water, oil or other liquids. Please put the equipment in dry ,cool and stable place.
- 5、 Do not plug adaptor with net hand to against electrical shock.
- 6、 Clean this tester with soft cloth. Firstly put cloth in the water of cleanser, then dry cloth and clean the tester. Do not use volatile chemical liquid, such as volatile, oil, thinner, alcohol, etc.
- 7、 Handle carefully while carrying and using the equipment.
- 8、 Do not disassemble ,repair or modify the tester by yourself.
- 9、 Please contact us if there is any problem and fault.

Part name and functions

STW side view:

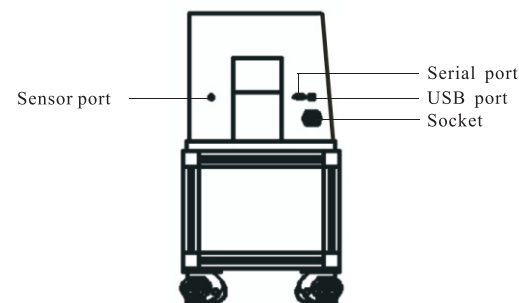

STW front view:

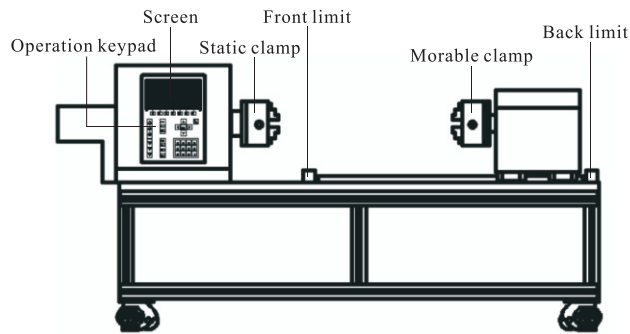

Part	Function
USB port	Connect to computer with special software
Serial port	Communicate to computer
Socket	Input: AC 220V ± 10%, 50/60HZ (earth needed)
Static clamp Movable clamp	Clamp measuring object
Front limit Back limit	Limit the move location of head
Sensor port	Connect to sensor

Operation keypad

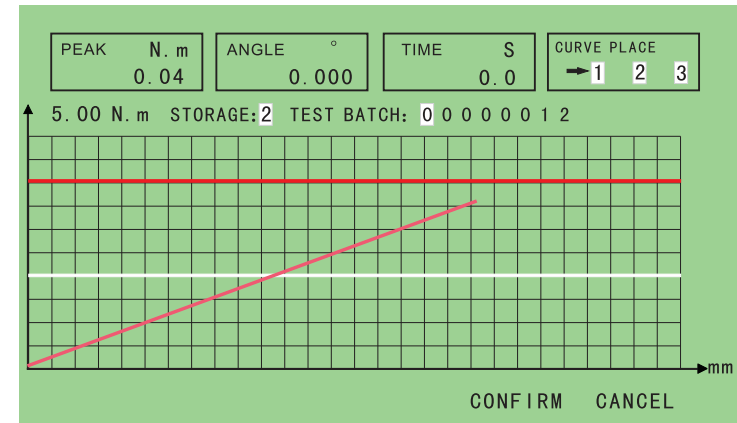
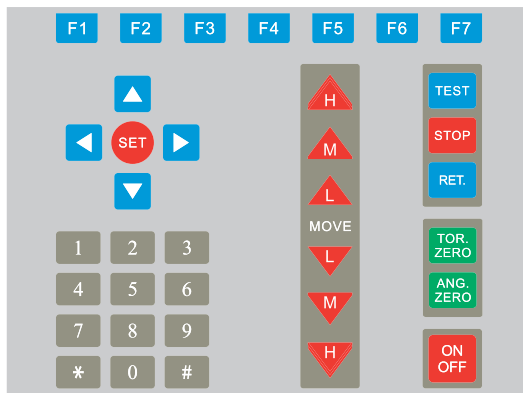

Note: adjust cursor by “▲” “▼” “◀” “▶” buttons, and modify test batch, then save curve to corresponding place which the “→” point out by pressing “CONFIRM” button and cancel save operation by pressing cancel button, back to interface of curve storage.

- ⑨ Report: view test report by pressing the button and enter interface of report viewing.
- ⑩ Data save: save peak and angle data to corresponding storage place by pressing the button.
- ⑪ Escape: return to work interface of initialization by pressing the button.
- ⑫ Detail: enter interface of curve details and view every point value by pressing the button.
- ⑬ Unit: automatic exchange among N.m/kgf.cm/lbf.in by pressing the button.

Note: Under test interface, pressing “STOP” button make the instruments stop testing and enter curve storage interface, or instrument finish the test according to the pre-set mode and enter curve storage interface.

4、Interface of curve storage

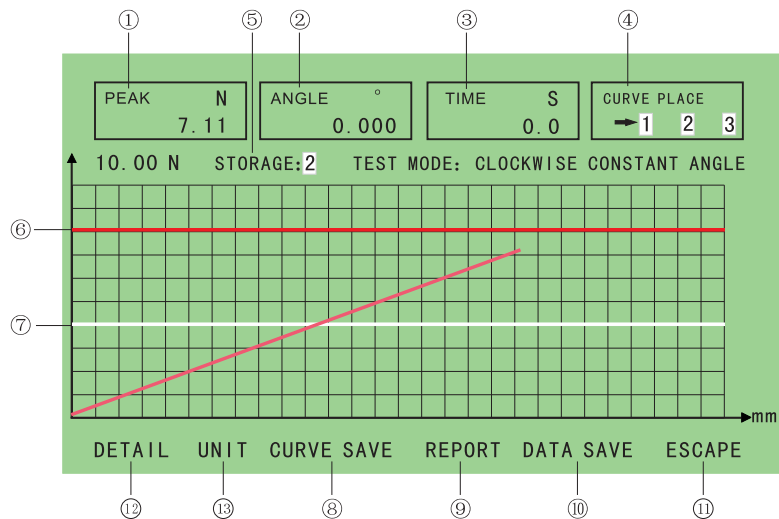

- ①Peak: max value.
- ②Angle: the angle after finishing test.
- ③Time: total test time.
- ④Curve place: save curve to corresponding place.
- ⑤Storage place: save peak and angle data.
- ⑥Upper limit line (red): if upper limit value exceed step value, the upper limit line does not display.
- ⑦Lower limit line(yellow): if lower limit value exceed step value, the lower limit line does not display.
- ⑧Curve save: pressing the button will appear the following interface:

Introduction of product functions

I 、 Quick start guide

Keys	Description
	Power switch ON/OFF.
	Under work interface of initialization, parameter setting.
	Under work interface of initialization, used for choosing storage place of current data. Under interface of parameters setting, used for moving cursor. Under interface of data viewing, used for choosing data storage place. Under interface of curve storage, used for choosing data storage place. Under interface of curve details, used for viewing last curve.
	Under work interface of initialization, used for choosing storage place of current data. Under interface of parameters setting, used for moving cursor. Under interface of data viewing, used for choosing data storage place. Under interface of curve storage, used for choosing data storage place. Under interface of curve details, used for viewing next curve.
	Under interface of parameters setting, used for moving cursor. Under interface of data viewing, used for choosing storage curve. Under interface of curve storage, used for choosing curve storage place. Under interface of curve details, used for viewing every point on curve. During curve saving, used for choosing number of test batch.
	Under interface of parameters setting, used for moving cursor. Under interface of data viewing, used for choosing storage curve. Under interface of curve storage, used for choosing curve storage place. Under interface of curve details, used for viewing every point on curve. During curve saving, used for choosing number of test batch.

	Under work interface of initialization, spin deasil with 1.5r/min by pressing the button.
	Under work interface of initialization, spin deasil with 0.15r/min by pressing the button.
	Under work interface of initialization, spin deasil with 0.015r/min by pressing the button.
	Under work interface of initialization, spin withershins with 0.015 r/min by pressing the button.
	Under work interface of initialization, spin withershins with 0.15 r/min by pressing the button.
	Under work interface of initialization, spin withershins with 1.5 r/min by pressing the button.
	Under work interface of initialization, current torque zero.
	Under work interface of initialization, current angle zero.
	Under work interface of initialization, start test by pressing the button.
	Under work interface of initialization, stop test by pressing the button.
	Under work interface of initialization, return to initial position by pressing the button.
	Under interface of parameters setting, used for changing parameter During curve saving, used for changing number of test batch.
	Under interface of parameters setting, used for changing parameter During curve saving, used for changing number of test batch.
Number button	Under interface of parameters setting ,used for changing parameter During curve saving, used for changing number of test batch.
Function button	F1、 F2、 F3、 F4、 F5、 F6、 F7 function buttons depend on the instruction of screen.

3) Constant angle mode(picture below)

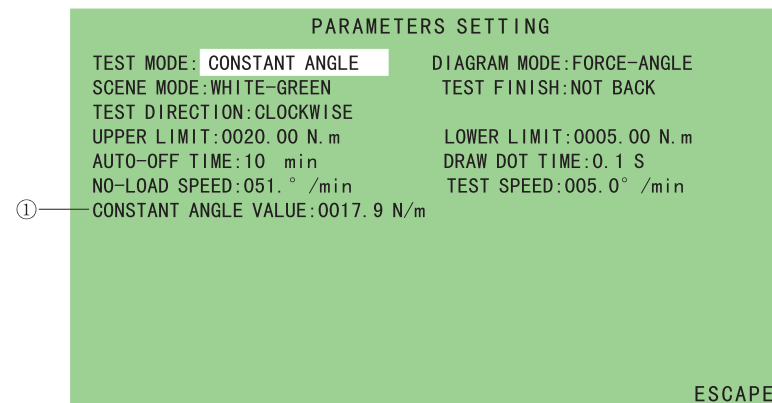

①Constant angle value: stop moving after reaching to pre-set angle.

Note: adjust cursor by “▲” “▼” “◀” “▶” buttons to set, then press “+” “-” or number key to change parameter, press the “ESCAPE” key to save the parameter after modification, and back to work interface of initialization.

3、 Test interface

Under work interface of initialization, pressing “” button make the instrument enter test interface.

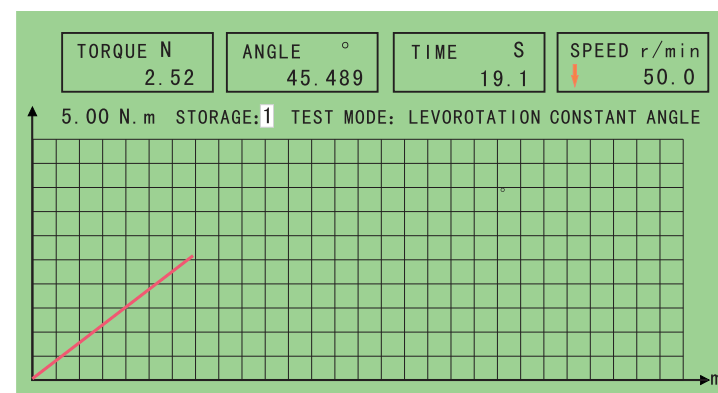

2) Constant torque mode (picture below)

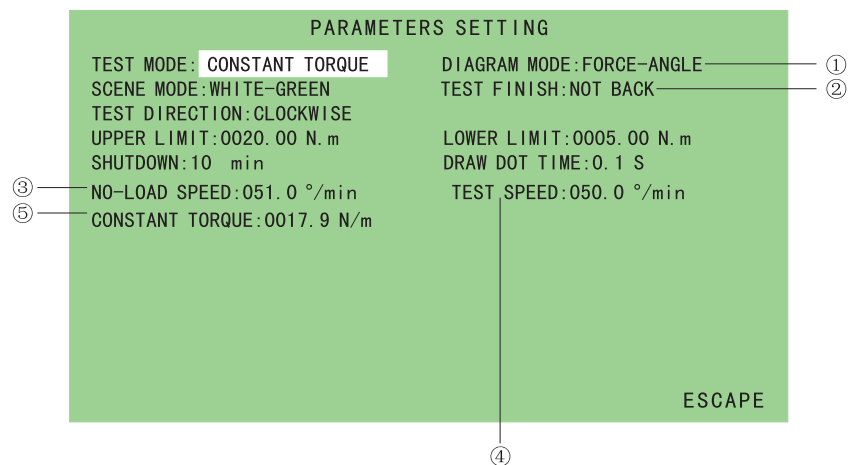

① Diagram mode: abscissa data setting of display curve

Torque-time: ordinate is torque, abscissa is time.

Torque- angle: ordinate is torque, abscissa is angle.

② Test finish: whether return after finishing test

Back: after finishing test, return to work interface of initialization, motor return to original location automatically.

Not Back: after finishing test, return to work interface of initialization, motor remain unchanged.

③ No-load speed: speed without load.

④ Test speed: speed of test.

⑤ Constant torque: stop moving after reaching to pre-set torque.

II、Functions details

1、Work interface of initialization

ON: press “

① Torque : current torque value

Touch “TORQUE” could reach to the interface of parameter settings for constant torque mode.

② Angle: current angle

Touch “ANGLE “ could reach to the interface of parameter settings for constant angle mode.

③ Time: measurement time.

④ Speed: current speed

Touch “SPEED” could reach to the interface of parameter settings for no-load speed and test speed

⑤ Step value: when the tester start to draw, if test value exceeds step

value, it will switch to next step.

- ⑥ Storage location: show current storage location, if the number color is white, it means that the location has data.
- ⑦ Test mode: show current test mode. Touching could reach to the interface of parameter settings.
- ⑧ Unit: three units (N.m/kgf.cm/lbf.in) automatic exchange by pressing the button.
- ⑨ View: enter view interface by pressing the button.
- ⑩ Save: save current data to storage location.

2、Interface of parameters setting

Under work interface of initialization, pressing “**SET**” button enter interface of parameters setting for choosing test mode.

Test mode: manual mode, constant torque mode, constant angle mode

Manual mode: manual operation and adjust the angle needed by pressing the six buttons “**△_H**” “**△_M**” “**△_L**” “**▽_L**” “**▽_M**” “**▽_H**”. Finally finish testing by pressing “**STOP**” button.

Constant torque mode: automatic operation, test torque under pre-set angle.

Constant angle mode: automatic operation, test angle under pre-set torque.

1) Manual mode (picture below)

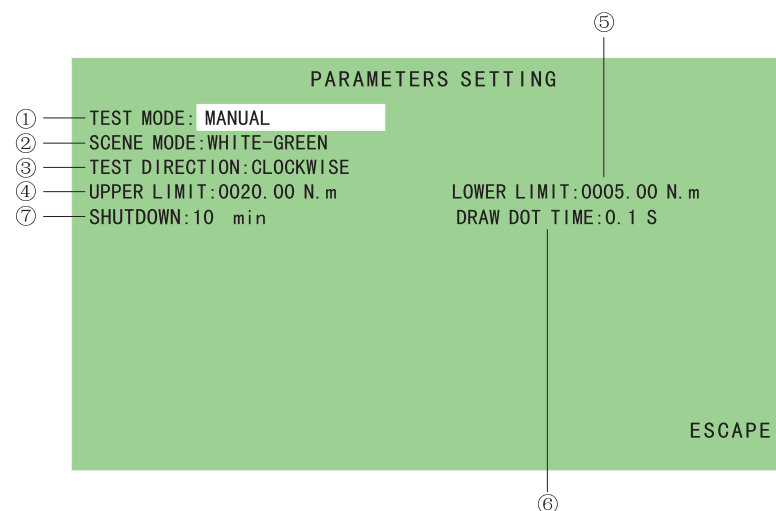

- ① Test mode: three test mode setting
manual mode/constant torque mode/constant angle mode.
- ② Scene mode: change among different background modes
White-green: white typeface, green background.
White-blue: white typeface, blue background.
White-grey: white typeface, grey background.
- ③ Test direction: choose motor rotate direction between clockwise and anticlockwise.
- ④ Upper limit: set upper limit value.
- ⑤ Lower limit: set lower limit value.
- ⑥ Draw dot time: the time interval of curve tracing (0.1-9.9 seconds free set).
- ⑦ Auto-off time setting (0-99 minutes, 0 means no shutdown).